

*tigé* 

# 2023

OWNER'S MANUAL



## FUEL SYSTEMS

Boats manufactured for use in California for model year 2018 and after meet the California EVAP Emissions regulation for spark-ignition marine watercraft. Boats meeting this requirement will have the following label affixed near the helm.

### WARNING

Operating, servicing and maintaining a recreational marine vessel can expose you to chemicals including engine exhaust, carbon monoxide, phthalates and lead, which are known to the State of California to cause cancer and birth defects or other reproductive harm. To minimize exposure, avoid breathing exhaust, service your vessel in a well-ventilated area and wear gloves or wash your hands frequently when servicing this vessel. For more information go to: [www.P65warnings.ca.gov/marine](http://www.P65warnings.ca.gov/marine)

The fuel system in boats marketed in states other than California complies with U.S. EPA-mandated evaporative emission standards at time of manufacture using certified components.

## CALIFORNIA AIR RESOURCES BOARD (CARB)

Outboard, sterndrive and inboard powered boats sold in the state of California are equipped with special components and certified to meet stricter environmental standards and exhaust emissions. All boats sold in California since 2009 are required to meet Super-Ultra-Low (four-star) emissions.

## EXHAUST EMISSIONS



Sterndrive and inboard marine engine powered boats meeting CARB's exhaust emission standards are required to display the four-star label on the outside of the hull above the waterline. Outboard and personal watercraft marine engines may also comply with these standards.

### DANGER

Carbon monoxide (CO) can cause brain damage or death. Engine and generator exhaust contains odorless and colorless carbon monoxide gas. Carbon monoxide will be around the back of the boat when engines or generators are running. Signs of carbon monoxide poisoning include nausea, headache, dizziness, drowsiness and lack of consciousness. Get fresh air if anyone shows signs of carbon monoxide poisoning. See engine manufacturer's manual for information regarding carbon monoxide poisoning.

# TABLE OF CONTENTS

<b>Introduction</b> . . . . .	<b>1-1</b>
Play It Safe and Enjoy! . . . . .	1-1
Tigé Tips for a Safe, Fun Day on the Water . . . . .	1-1
Owner's Kit . . . . .	1-2
Owner's Manual . . . . .	1-2
Intended Use . . . . .	1-2
Owner Responsibility For Warranty Procedure . . . . .	1-3
Before Operating . . . . .	1-3
Warranty Service Requirements . . . . .	1-3
If You Sell Your Tigé Boat . . . . .	1-3
Certifications . . . . .	1-3
National Marine Manufacturers Association (NMMA) . . . . .	1-3
Engines . . . . .	1-4
References and Contact Information . . . . .	1-4
Features and Technology . . . . .	1-7
Convex V Hull/TAPS . . . . .	1-7
Zero Off GPS Cruise Control . . . . .	1-7
Advanced CAN Bus Technology . . . . .	1-7
Product Improvement . . . . .	1-8
Serial Number Locations . . . . .	1-8
Boating Terminology . . . . .	1-9
Specifications 25ZX . . . . .	1-10
Specifications 23ZX . . . . .	1-12
Specifications 21ZX . . . . .	1-14
Specifications Z5 . . . . .	1-16
Specifications Z3 . . . . .	1-18
Specifications Z1 . . . . .	1-20
Specifications 24RZX . . . . .	1-22
Specifications 22RZX . . . . .	1-24
Specifications 20RZX . . . . .	1-26
2023 Tigé Limited Warranty . . . . .	1-28
Australian Consumers Only . . . . .	1-33
<b>Safety</b> . . . . .	<b>2-1</b>
Good Boating Practices . . . . .	2-1
Safety and Training . . . . .	2-4
Strong Points . . . . .	2-4



# TABLE OF CONTENTS

Safety Labels . . . . .	2-4
Safety Statements . . . . .	2-5
Safety Precautions . . . . .	2-6
Overloading . . . . .	2-12
Required Boating Safety Equipment and Regulations . . . . .	2-14
Fire Extinguisher . . . . .	2-16
Engine Emergency Stop Switch and Lanyard . . . . .	2-16
Life Jackets . . . . .	2-17
Visual Distress Signaling (VDS) Devices . . . . .	2-22
Audible Signaling Devices . . . . .	2-25
Navigational Lights . . . . .	2-25
Recommended Safety Equipment . . . . .	2-27
Personal Location Beacon (PLB) . . . . .	2-27
Situational Awareness . . . . .	2-28
Driving Defensively . . . . .	2-28
Small Boats and Swimmers . . . . .	2-28
Knowing the Boat . . . . .	2-29
Special Needs Passengers . . . . .	2-29
Cruising Limitations . . . . .	2-30
Hazard Information . . . . .	2-31
Water Sports . . . . .	2-32
Develop Water Sense . . . . .	2-32
Platform Dragging . . . . .	2-33
Water Sports Guidelines . . . . .	2-34
<b>Boating Regulations and Your Responsibilities . . . . .</b>	<b>3-1</b>
Boat Owner / Operator Responsibilities . . . . .	3-1
Safety . . . . .	3-1
Registration . . . . .	3-2
Insurance . . . . .	3-2
Reporting Accidents . . . . .	3-2
Boating Under the Influence . . . . .	3-3
Operator's License and Education . . . . .	3-3
Operation By Minors . . . . .	3-3
Emergency Assistance . . . . .	3-4
Negligent Operation . . . . .	3-4



Restricted Areas . . . . .	3-5
America’s Waterway Watch . . . . .	3-6
Fishing . . . . .	3-6
Wake . . . . .	3-7
Noise . . . . .	3-7
Speed . . . . .	3-7
Shallow Water Boat Stability . . . . .	3-7
Protecting the Environment . . . . .	3-8
Aquatic Invasive Species (AIS) . . . . .	3-9
Paints . . . . .	3-10
Cleaning Agents . . . . .	3-10
Exhaust Emissions . . . . .	3-10
<b>Emergencies . . . . .</b>	<b>4-1</b>
First Aid / Medical Emergencies . . . . .	4-1
Emergency Preparation Checklist . . . . .	4-1
Using Distress Signals . . . . .	4-1
Requesting Assistance (Non-Distress Call) . . . . .	4-2
Fire and Explosion . . . . .	4-3
Man Overboard (MOB) . . . . .	4-4
Capsizing and Flooding . . . . .	4-5
Running Aground . . . . .	4-5
Dangerous Weather . . . . .	4-6
Engine or Boat System Failure . . . . .	4-6
Accidents, Collisions and Giving Assistance . . . . .	4-6
Towing on the Water . . . . .	4-7
Law of Salvage . . . . .	4-8
Hurricane and Severe Weather Preparedness . . . . .	4-9
Protecting the Boat from Theft . . . . .	4-9
<b>Operating in Hazardous Conditions . . . . .</b>	<b>5-1</b>
Severe Weather . . . . .	5-1
Storm Conditions . . . . .	5-1
Fog Conditions . . . . .	5-2
Reduced Visibility . . . . .	5-2
Cold Weather . . . . .	5-2
Water Hazards . . . . .	5-2
Aquatic Vegetation / Weeds . . . . .	5-3
Dams and Spillways . . . . .	5-3



# TABLE OF CONTENTS

Shallow Water Operation . . . . .	5-3
Markers, Warnings and Advisories . . . . .	5-4
Boat Flags . . . . .	5-4
Harbor Flags and Indicators . . . . .	5-5
<b>Navigation Rules and Aids . . . . .</b>	<b>6-1</b>
Rules of the Road . . . . .	6-1
Right-of-Way . . . . .	6-1
Crossing . . . . .	6-2
Meeting Head-On . . . . .	6-3
Overtaking / Passing . . . . .	6-4
Audible Signals . . . . .	6-4
Aids to Navigation . . . . .	6-5
Buoys . . . . .	6-6
Daymarks / Dayboards . . . . .	6-7
Lights and Lighted Structures . . . . .	6-7
Markers . . . . .	6-9
Navigational Lights and Night Operation . . . . .	6-13
<b>Features . . . . .</b>	<b>7-1</b>
General Layouts . . . . .	7-1
Dash Panels . . . . .	7-1
Tigé Clear Dash . . . . .	7-2
Switches, Controls, Ports, Gauges and Indicators . . . . .	7-2
Bilge (Bilge Pump) . . . . .	7-2
Blower (Engine Compartment / Bilge Area Blower) . . . . .	7-3
Courtesy (Courtesy Lights) . . . . .	7-3
Docking (Docking Lights) . . . . .	7-3
NAV (Navigation Lights) . . . . .	7-3
Emergency Stop Switch . . . . .	7-3
Horn . . . . .	7-4
Ignition Key Switch . . . . .	7-4
Controls . . . . .	7-5
Shifter / Throttle Control . . . . .	7-5
Smart2 Wheel Controls . . . . .	7-6
GO System Edit Settings . . . . .	7-7
TAPS 3T . . . . .	7-8

# TABLE OF CONTENTS



SurfLink® Remote . . . . .	7-8
Tigé Zero Off GPS Cruise Control Panel . . . . .	7-8
Steering Tilt Lever . . . . .	7-8
Stereo Remote—Optional . . . . .	7-8
Heater—Optional. . . . .	7-8
Ports . . . . .	7-9
12-Volt Ports—Throughout the Boat. . . . .	7-9
iPod™/MP3 Port—Optional . . . . .	7-9
Gauges . . . . .	7-9
Setting the Zero Off GPS Cruise Control Display Units . . . . .	7-10
Fuses . . . . .	7-11
Cockpit and Exterior. . . . .	7-11
Tigé/ATX Keyless Ignition Operation. . . . .	7-11
Battery Disconnect Switch . . . . .	7-12
Swim Platform . . . . .	7-12
Bow Features of Your Tigé . . . . .	7-12
Walk-Thru Windshield Opening / Latching . . . . .	7-13
Cockpit Seating. . . . .	7-13
EIDB Dual-Battery System—If Equipped . . . . .	7-13
Batteries . . . . .	7-13
Engine Compartment Cover . . . . .	7-14
V-Drive Models . . . . .	7-14
Powered Captain’s Chair . . . . .	7-14
Observer’s Seat. . . . .	7-14
Flip-Up Observer’s Seat—If Equipped . . . . .	7-15
Heated Seats—Optional . . . . .	7-15
Storage Hatch . . . . .	7-15
Retractable Pylon . . . . .	7-15
Water Sports Tow Pylon Safety . . . . .	7-16
Alpha E3 Tower . . . . .	7-17
Alpha E3+ with SolidSHADE . . . . .	7-19
Center Housing Safety Latch . . . . .	7-19
Lowering Tower. . . . .	7-19
Raising Tower . . . . .	7-20
Towing/trailing With Solidshade. . . . .	7-20
Solidshade Canvas . . . . .	7-21



# TABLE OF CONTENTS

Installing Plug and Play Board Bags . . . . .	7-21
Alpha E3 Bimini . . . . .	7-22
Trailing or Towing with a bimini: . . . . .	7-23
Cove Cover for E3 Tower—If Equipped . . . . .	7-23
Cove Cover for E3+ with SolidShade— If Equipped. . . . .	7-24
Backup Camera—If Equipped . . . . .	7-24
Pull-Out Cleats. . . . .	7-25
Mooring Boat Cover (Tower Up) - If Equipped . . . . .	7-25
Alpha E3 Outer Armor Cover (Over Tower)— If Equipped. . . . .	7-26
Alpha E3+ with SolidShade Outer-Armor Cover (Over Tower Cover) . . . . .	7-27
Plug and Play Ballast. . . . .	7-28
ZX/RZX Reversible Seat and Table . . . . .	7-28
Z Series Reversible Bench. . . . .	7-29
<b>Operating the Boat. . . . .</b>	<b>8-1</b>
Before Launch . . . . .	8-1
Safety Equipment . . . . .	8-2
Float Plan . . . . .	8-2
Preflight Checklist . . . . .	8-2
Before Towing . . . . .	8-3
Pre-Operation . . . . .	8-3
Checks During Operation . . . . .	8-3
Boarding . . . . .	8-3
Boat Loading . . . . .	8-4
Fueling . . . . .	8-4
Fuel Management. . . . .	8-4
Fuel Suppliers. . . . .	8-4
Static Electricity and the Fuel System . . . . .	8-5
Fuel (Gasoline) . . . . .	8-5
Before Refueling . . . . .	8-7
Refueling. . . . .	8-7
Refueling Built-In Fuel Tanks . . . . .	8-8
After Refueling . . . . .	8-8
Launch . . . . .	8-8
Starting . . . . .	8-8





Steering . . . . .	8-9
Shifting . . . . .	8-9
Stopping . . . . .	8-10
Checks After Operation . . . . .	8-10
Docking . . . . .	8-10
Dock and Mooring Lines . . . . .	8-10
TAPS Operation . . . . .	8-12
TAPS 3T Operation . . . . .	8-13
Ride, Safety and Boat Performance . . . . .	8-14
Zero Off GPS Cruise Control Operations . . . . .	8-14
To Set Zero Off GPS Cruise Control . . . . .	8-15
Troubleshooting . . . . .	8-16
Running . . . . .	8-17
Maneuvering Techniques . . . . .	8-17
Salt Water . . . . .	8-17
Salt and Hard Water Operation . . . . .	8-18
External Care . . . . .	8-18
Internal (Cooling System) Care . . . . .	8-18
Freshwater Cooling – Half Systems . . . . .	8-18
Freshwater Cooling . . . . .	8-19
Winterization . . . . .	8-20
Towing Procedure . . . . .	8-20
Anchoring . . . . .	8-21
Dropping Anchor . . . . .	8-21
Weighing (Pulling in) Anchor . . . . .	8-22
Performance Boating . . . . .	8-22
Before Running . . . . .	8-22
When Underway . . . . .	8-23
Propellers . . . . .	8-23
<b>Boat Systems . . . . .</b>	<b>9-1</b>
Steering System . . . . .	9-1
Engine . . . . .	9-2
Transmission . . . . .	9-2
V-Drives . . . . .	9-2
Propellers . . . . .	9-2
Strut and Bearing . . . . .	9-2
Electrical System . . . . .	9-3



# TABLE OF CONTENTS

Fuel System . . . . .	9-3
Ballast System . . . . .	9-3
Bilge Systems . . . . .	9-4
Stern Thruster (Optional) . . . . .	9-5
Transom Flip-Up Seats (ZX/RZX Line) . . . . .	9-5
Transom Flip-Up Seats (Z Line) . . . . .	9-5
EZDrive Thrusters . . . . .	9-6
Important Thruster User Precautions and Considerations . . . . .	9-6
Schematic and System Illustrations . . . . .	9-9
<b>Trailer and Launching . . . . .</b>	<b>10-1</b>
Legal Considerations . . . . .	10-1
Trailer Classification . . . . .	10-1
Trailer Type . . . . .	10-1
Trailer Gross Vehicle Weight Rating . . . . .	10-2
Towing Vehicle . . . . .	10-2
Vehicle Towing Hitch . . . . .	10-2
Hitch Ball and Trailer Coupler . . . . .	10-3
Safety Chains . . . . .	10-4
Trailer Brakes . . . . .	10-5
5-Pin Wiring Connector . . . . .	10-5
Trailer Guidelines . . . . .	10-6
Engine-Transom Support Bracket . . . . .	10-6
Backing Up . . . . .	10-9
Launching . . . . .	10-9
Loading Guidelines . . . . .	10-11
Reporting Safety Defects . . . . .	10-11
<b>Care and Maintenance . . . . .</b>	<b>11-1</b>
Safety Equipment . . . . .	11-1
Life Jackets . . . . .	11-1
General Maintenance . . . . .	11-3
Interior . . . . .	11-4
Care and Cleaning of Interior—Cool Touch / Chil Cool™ Vinyl . . . . .	11-4
Care and Cleaning of Interior—Standard Vinyl . . . . .	11-5
Cleaner Recommendations . . . . .	11-6



Non-Skid Flooring Cleaning Instructions . . . . .	11-7
Dark Stowage Areas . . . . .	11-7
Bilge Pump and Bilge Area . . . . .	11-8
Exterior . . . . .	11-8
Gelcoat Maintenance . . . . .	11-9
Propeller . . . . .	11-11
Rudder . . . . .	11-12
Saltwater Corrosion . . . . .	11-12
Batteries . . . . .	11-13
Transmission Oil Level Inspection . . . . .	11-16
Steering System . . . . .	11-16
Sea Strainer Maintenance . . . . .	11-18
Flushing the Engine . . . . .	11-19
Unscheduled Maintenance . . . . .	11-20
Engine / Propulsion / Cooling System . . . . .	11-20
Electrical System . . . . .	11-20
Winterization and Storage Preparation . . . . .	11-21
<b>Troubleshooting and Service Requirements . . . . .</b>	<b>12-1</b>
20-Hour Service Requirements . . . . .	12-4
70-Hour Service Requirements . . . . .	12-5
120-Hour Service Requirements . . . . .	12-7
170-Hour Service Requirements . . . . .	12-8
220-Hour Service Requirements . . . . .	12-10
270-Hour Service Requirements . . . . .	12-11
Original Owner Information . . . . .	12-13
Second Owner Information . . . . .	12-13
Fuel Log . . . . .	12-14
Float Plan . . . . .	12-16
Survival Equipment . . . . .	12-17
Persons Onboard . . . . .	12-17
<b>Index . . . . .</b>	<b>I-1</b>



# TABLE OF CONTENTS

This Page Intentionally Left Blank

# Section 1

## INTRODUCTION

Congratulations on your purchase of a Tigé, the world's most versatile inboard! We're confident you will enjoy Tigé's extraordinary blend of world-class water sports performance, incredible versatility and outstanding user convenience.

Before using your new Tigé, we encourage you to thoroughly review this owner's manual and familiarize yourself with your boat's operational and safety features.

We have made every effort to ensure the accuracy of this manual, providing the most current information available. Since we are continuously refining features and design, Tigé periodically makes changes to models, systems and specifications. These changes are included in an updated online version of this owner's manual available at [www.tige.com](http://www.tige.com).

If you have any questions concerning your new Tigé or this manual, please contact your Tigé dealer. Once again, thanks for choosing Tigé. Have a great time!

### PLAY IT SAFE AND ENJOY!

Safety is a top priority in the design and construction of every Tigé boat. Before use, we strongly encourage owners and operators to become familiar with Tigé safety features, safe operation, maintenance procedures and overall safe boating practices. In addition to ensuring your safety and that of your passengers, proper maintenance and operation of your Tigé greatly enhance your enjoyment on the water.

### TIGÉ TIPS FOR A SAFE, FUN DAY ON THE WATER

A day on the water may be relaxing for you, but cruising through chop, towing skiers and other normal boating activity puts significant stress on a boat. Although your Tigé is built tough to withstand the rigors of on-water activities, you should check and tighten pylons, towers, accessories and other attachments every time you go out to avoid injury and ensure safe reliable performance. It is also very important to regularly check and maintain the various systems and equipment on your boat before you get underway.

To help you keep everything in good working order, refer to the *Preflight Checklist* in *Section 8* each time you go boating. Make it a habit and you'll make the most out of your time on the water.



## **OWNER'S KIT**

The Owner's Kit contains the owner's manual and may include other information about accessories or components offered with your Tigé boat. This information is provided by the manufacturers of those products and should be read, kept and referred to whenever you are using the accessory or component, or before you put it into use. Refer to these manufacturers' manuals for additional operation and maintenance instructions not covered in this manual.

## **OWNER'S MANUAL**

The owner's manual contains information concerning the operation and care of your boat. The descriptions contained within the manual will introduce you to features of Tigé and provide you the general knowledge of how the boat works. Become familiar with the information in each section before you use your boat.

Even if everything has been planned and designed for the safety of the boat and its users, boating is still highly dependent on the weather conditions, water conditions, and the experience of you and your passengers. One can never ensure full safety.

It is your responsibility as the owner or user to know the boat's equipment, capabilities and intended use. The specific information on the operation of the equipment and systems on your boat should be supplied by that manufacturer. Read, understand and keep all the information supplied, and familiarize yourself and all users with the boat before you put it into use.

## **INTENDED USE**

Your Tigé boat is intended for use as a pleasure and sport craft and a Category C craft design.

This craft is designed to operate in winds up to Beaufort force 6 and the associated wave heights and significant wave heights up to 6'6.7" (2 m). Such conditions may be encountered in exposed inland waters, in estuaries, and in coastal waters in moderate weather conditions.



## OWNER RESPONSIBILITY FOR WARRANTY PROCEDURE

### BEFORE OPERATING

Before operating your new Tigé boat, read and understand this manual and the warranty and take the time to read about other accessories or components offered with your Tigé boat.

### WARRANTY SERVICE REQUIREMENTS

All Tigé warranty service must be completed by a Tigé dealer. If you are not able to return your boat to your dealership, contact them so they can assist you in coordinating the warranty service. Any claims against Tigé Boats without prior approval from Tigé Boats on repairs completed by an unauthorized dealership may be denied.

### IF YOU SELL YOUR TIGÉ BOAT

Warranties are transferable. If you choose to sell your Tigé boat to anyone other than a Tigé dealer, contact Tigé Boats for the appropriate warranty transfer information: [www.tige.com](http://www.tige.com) or 325.676.7777. If the transfer procedures are not followed, future warranty service may be denied.

## CERTIFICATIONS

### NATIONAL MARINE MANUFACTURERS ASSOCIATION (NMMA)

Tigé Boats is a member of the NMMA. This independent organization's members include boat, engine and marine equipment manufacturers that are focused on the improvement and safety of boating.

Your new Tigé boat is NMMA certified. An NMMA certification not only satisfies the U.S. Coast Guard (USCG) regulations but also the more rigorous equipment and system standards based on those established by the American Boat and Yacht Council, Inc. (ABYC). Your Tigé boat meets or exceeds NMMA safety-based certifications.



## ENGINES

Our engine manufacturer works closely with Tigé to ensure that its engines deliver maximum performance, reliability and customer satisfaction. Part of this commitment is a certification program that provides Tigé dealers and service technicians with ongoing training and information about our engines. Certified engine service personnel must attend periodic service schools held at the Tigé headquarters. The training includes review of all manufacturing and installation processes, proper servicing procedures as well as existing and developing engine technologies.

## REFERENCES AND CONTACT INFORMATION

Use the following list of publications and organizations for reference and contact information concerning safe boating, navigational rules and other boating topics.

### Publications

- Bottomley, Tom. *Boatman's Handbook*. Hearst Marine Book. Morrow
- Brotherton, Miner. *Twelve Volt Bible*. Seven Seas
- Calder, Nigel. *Boatowner's Mechanical and Electrical Manual*. McGraw-Hill Education
- Chapman, Charles F. and Maloney, E.S. *Chapman's Piloting, Seamanship and Small Boat Handling*. Hearst Marine Book. Morrow
- Hinz, Earl. *The Complete Book of Anchoring and Mooring*. Cornell Maritime Press
- National Fire Protection Association. *NFPA 302 Fire Protection Standard for Pleasure and Commercial Motor Craft*. National Fire Protection Association
- United States Coast Guard. *Navigational Rules for U.S. Waterways*. Visit <https://www.navcen.uscg.gov/> to view or download this publication.
- United States Coast Guard Auxiliary. *Boating Skills and Seamanship Thirteenth Edition*. United States Coast Guard
- Whiting, John and Bottomley, Tom. *Chapman's Log and Owner's Manual*. Hearst Marine Book





## **Organizations**

### ***American Boat & Yacht Council***

Boat building standards.  
<http://abycinc.org>

### ***American Red Cross***

A resource for first aid training, emergency supplies and preparedness.  
<http://www.redcross.org> or consult the local telephone directory

### ***Boat Owners Association of The United States***

Organization of recreational boaters offering marine services, education and protecting boater's rights.  
<http://www.boatus.com/>

### ***BoatU.S. Foundation for Boating Safety Hotline***

Training and education outreach directly to boaters.  
<http://www.boatus.org/>  
Phone: 800-245-2628

### ***National Association of State Boating Law Administrators***

Boat safety training and education resources.  
<http://www.nasbla.org>

### ***National Marine Manufacturers Association***

Boat, marine engine and accessory manufacturer trade association.  
<http://www.nmma.org>

### ***National Oceanic and Atmospheric Administration's National Weather Service***

Nautical charting, weather, fishery, ocean and climate resources.  
<http://www.noaa.gov>

### ***National Safe Boating Council, Inc.***

<http://www.safeboatingcouncil.org>

### ***Sea Tow Services International, Inc.***

Organization of recreational boaters providing towing and more.  
<http://www.seatow.com>  
Toll free: 800-473-2869

***U.S. Coast Guard***

<http://www.uscgboating.org> (To contact the U.S. Coast Guard for an emergency while on the water, always use the onboard VHF-FM radio channel 16. Use cell phones only as a secondary means of communication. Call 9-1-1 to reach rescue personnel.)

***U.S. Coast Guard Auxiliary***

Information on boating safety classes and boat safety checks.  
<http://nws.cgaux.org>; Phone: 877-875-6296

***U.S. Coast Guard Navigation Center (NAVCEN)***

USCG navigation information.  
<https://www.navcen.uscg.gov>

***U.S. Coast Guard Office of Boating Safety***

USCG resources for recreational boaters.  
<http://www.uscgboating.org>

***U.S. Coast Guard's America's Waterway Watch Program***

A program for recreational boaters to assist the U.S. Department of Homeland Security in reporting suspicious activity on U.S. waterways; Phone: 877-249-2824

***U.S. Government Publishing Office***

<http://www.gpo.gov>  
(For information and documentation on FCC rules and regulations and Skippers Course information, and other government, marine and nautical related documents)

***U.S. Power Squadrons***

Boating courses and knowledge resources.  
<http://www.usps.org>; Phone: 888-367-8777

***Water Sports Industry Association***

Water sports education, safety and risk management.  
<http://www.wsia.net>



## FEATURES AND TECHNOLOGY

### CONVEX V HULL/TAPS

The unique, patented shape of the Tigé Convex V hull combined with TAPS technology are key to Tigé's superior multi-sport versatility, incredible performance and unmatched ride. All other inboard hulls curve down with a "hook" toward the transom and must rely on heavy ballast or drag hardware to produce even entry-level wakeboarding wakes. The Convex V hull curves up in a rocker shape like a wakeboard or slalom ski. Tigé uses its breakthrough TAPS technology to control hull running attitude and wake characteristics. At wakeboarding speed with TAPS in the up position, the bow rises and the Convex V hull settles naturally, creating tremendous water displacement and huge world-class wakes without ballast or drag hardware. A push of a button adjusts TAPS down, lowers the bow and creates instant planing and slalom-type wakes.

Ride, handling and fuel efficiency are also dramatically enhanced, allowing Tigé to deliver outstanding overall performance unmatched by any other inboard.

### ZERO OFF GPS CRUISE CONTROL

Standard on all Tigé models, Zero Off GPS Cruise Control is the most advanced precision digital speed control in the marine industry. It is also the easiest to use. The Zero Off GPS Cruise Control control panel incorporates touch pad and touch screen recognition for easy fingertip use without taking your eyes off the waterway. Zero Off GPS Cruise Control readouts are displayed on the Tigé CLEAR XL Touch Screen. You can even preset a preferred speed and precisely hit that speed set after set. Perfect double-ups and consistent towing speeds are now at your fingertips.

### ADVANCED CAN BUS TECHNOLOGY

Tigé Electronic Control (TEC) components are in constant communication with the engine's computerized ECM using advanced E-Control electronics. State-of-the-art CAN bus technology allows components to communicate hundreds of times a second over a simple, reliable, two-wire system. Keeping the juice flowing and the electronics humming is our Central Electronic Distribution Center (GEDC), which increases electrical system reliability and efficiency through circuit simplification and load management. CEDC also stabilizes electrical output throughout the boat, significantly reducing power spikes.



## PRODUCT IMPROVEMENT

Because of Tigé's commitment to continuous product improvement, the illustrations used in this manual may not exactly match your boat and are intended only as representation for reference views. Some illustrations may also show optional accessories, which may or may not be available for your boat. Some optional accessories can only be installed at the time the boat is manufactured and cannot be installed by your dealer. Your dealer can help with any questions you may have on options, which can be added to your boat.

## SERIAL NUMBER LOCATIONS

Your Tigé boat, its engine, propulsion unit and other equipment onboard are identified with a serial number. These identification numbers associated with your boat are extremely important. Prepare a list of all serial number items and store it in a safe place other than onboard the boat. Refer to the equipment operator's manuals supplied in your Owner's Kit for location of serial numbers.

Record these numbers below.

### ***Hull Identification Number (HIN)***

Located at the top, right (starboard) corner of the transom.

HIN: \_\_\_\_\_

Ignition Key, a key tag, is also provided with the keys; store tag or destroy.

Key Number: \_\_\_\_\_

Registration Number/State: \_\_\_\_\_

Date of Purchase: \_\_\_\_\_

Dealership Name and Address: \_\_\_\_\_

Phone: \_\_\_\_\_

Salesperson: \_\_\_\_\_

### ***Engine***

Engine Serial Number: \_\_\_\_\_

Engine Manufacturer: \_\_\_\_\_

Model: \_\_\_\_\_

Horsepower: \_\_\_\_\_



### Transmission

Transmission Serial Number: \_\_\_\_\_

Model: \_\_\_\_\_

### Trailer

Serial Number: \_\_\_\_\_

Manufacturer: \_\_\_\_\_

## BOATING TERMINOLOGY

An easy way to remember PORT side from STARBOARD side is “PORT” and “LEFT” both have four letters.



**SPECIFICATIONS 25ZX**

Length.....	25' (7.6 m)
Boat Beam.....	102" (259 cm)
Weight .....	6,300 lbs (2,858 kg)
Ballast.....	4,700 lb (2,131.88 kg)
Fuel Capacity.....	80 gal (303 l)
Hull .....	ConvexV
Seating.....	19
Draft.....	29" (74 cm)
Storage .....	131.38 ft <sup>3</sup> (3.72 m <sup>3</sup> )
Freeboard .....	3'6"
Standard Total Ballast .....	4,700 lbs
Standard Sub-Floor Ballast .....	3,000 lbs
Standard Plug & Play Ballast.....	1,700 lbs
Overall Length with out Platform .....	25'7"
Overall Length with Platform .....	26'8"
Overall Length with Platform & Trailer (triple axle, trailer tongue extended) .....	32'1"
Overall Length with Platform & Trailer (triple axle, trailer tongue folded) .....	29'3"
Trailer Minimum Width.....	102"
Trailer Maximum Width (with removable guide poles) .....	106"
Height, Tower Folded with Racks (18" Wheels) .....	9'
Height, Tower Folded with out Racks (18" Wheels) .....	8'8"
Height, Tower Up on Trailer .....	11'2"
Height, Tower Up on Water .....	7'10"
Height E3+ with SolidShade Tower Folded with Racks (18" Wheels).....	9'2.5"
Height E3+ with SolidShade Tower Folded with out Racks (18" Wheels).....	8'11"
Height E3+ with SolidShade Tower Up on Trailer .....	11'7"
Height E3+ with SolidShade Tower Up on Water .....	8'3"
Weight – Boat & Trailer (Double Axle).....	8,000 lbs
Weight – Boat & Trailer (Triple Axle) .....	8,100 lbs
Weight Capacity .....	2,660 lbs

*Tigé Boats reserves the right to change specifications, features, color schemes and pricing at any time without notice or incurring obligations. Trailer specifications, weights, details and features may vary depending on options and are subject to change.*



● = Designated Occupant Position

**SPECIFICATIONS 23ZX**

Length.....	23'5" (7.2 m)
Boat Beam.....	102" (259 cm)
Weight .....	5,950 lbs (2,699 kg)
Ballast.....	3,950 lb (1,791.7 kg)
Fuel Capacity.....	57 gal (216 l)
Hull .....	ConvexV
Seating.....	16
Draft.....	29" (74 cm)
Storage.....	121.67 ft <sup>3</sup> (3.45 m <sup>3</sup> )
Freeboard .....	3'3"
Standard Total Ballast.....	3,950 lbs
Standard Sub-Floor Ballast.....	2,500 lbs
Standard Plug & Play Ballast.....	1,450 lbs
Overall Length with out Platform.....	24'3"
Overall Length with Platform .....	25'4"
Overall Length with Platform & Trailer (trailer tongue extended).....	29'6"
Overall Length w/ Platform & Trailer (trailer tongue folded) .....	27'4"
Trailer Minimum Width.....	102"
Trailer Maximum Width (with removable guide posts) .....	106"
Height, Tower Folded with Racks (18" Wheels) .....	8'11"
Height, Tower Folded with out Racks (18" Wheels).....	8'7"
Height, Tower Up on Trailer .....	11'1"
Height, Tower Up on Water.....	7'8"
Height E3+ with SolidShade Tower Folded with Racks (18" Wheels).....	9'1.5"
Height E3+ with SolidShade Tower Folded with out Racks (18" Wheels).....	8'10"
Height E3+ with SolidShade Tower Up on Trailer .....	11'6"
Height E3+ with SolidShade Tower Up on Water .....	8'1"
Weight – Boat & Trailer (Double Axle).....	7,600 lbs
Weight Capacity .....	2,650 lbs

*Tigé Boats reserves the right to change specifications, features, color schemes and pricing at any time without notice or incurring obligations. Trailer specifications, weights, details and features may vary depending on options and are subject to change.*





● = Designated Occupant Position

**SPECIFICATIONS 21ZX**

Length.....	21'6" (6.6 m)
Boat Beam.....	102" (259 cm)
Weight .....	5,500 lbs (2,495 kg)
Ballast.....	3,100 lb (1,406.13 kg)
Fuel Capacity.....	46 gal (174 l)
Hull .....	ConvexV
Seating.....	14
Draft.....	29" (74 cm)
Storage .....	92.54 ft <sup>3</sup> (2.62 m <sup>3</sup> )
Freeboard.....	3'2"
Standard Total Ballast .....	3,100 lbs
Standard Sub-Floor Ballast .....	2,000 lbs
Standard Plug & Play Ballast.....	1,100 lbs
Overall Length with out Platform.....	22'6"
Overall Length with Platform .....	23'7"
Overall Length with Platform & Trailer (trailer tongue extended).....	27'7"
Overall Length with Platform & Trailer (trailer tongue folded).....	25'9"
Trailer Minimum Width.....	102"
Trailer Maximum Width (with removable guide poles) .....	106"
Height, Tower Folded with Racks (18" Wheels) .....	8'9"
Height, Tower Folded with out Racks (18" Wheels) .....	8'5"
Height, Tower Up on Trailer .....	10'11"
Height, Tower Up on Water.....	7'7"
Height E3+ with SolidShade Tower Folded with Racks (18" Wheels).....	8'11.5"
Height E3+ with SolidShade Tower Folded with out Racks (18" Wheels).....	8'8"
Height E3+ with SolidShade Tower Up on Trailer .....	11'4"
Height E3+ with SolidShade Tower Up on Water .....	8'0"
Weight – Boat & Trailer (Standard trailer) .....	7,000 lbs
Weight Capacity .....	2,045 lbs

*Tigé Boats reserves the right to change specifications, features, color schemes and pricing at any time without notice or incurring obligations. Trailer specifications, weights, details and features may vary depending on options and are subject to change.*



● = Designated Occupant Position

**SPECIFICATIONS Z5**

Length.....	25'5" (7.62 m)
Boat Beam.....	102" (259 m)
Weight .....	6,100 lbs (2,767 kg)
Ballast.....	4,400 lbs (1,995.81 kg)
Fuel Capacity.....	79 gal (299 l)
Hull .....	ConvexV
Seating.....	18
Draft.....	29" (74 cm)
Storage .....	137.49 ft <sup>3</sup> (3.89 m <sup>3</sup> )
Freeboard.....	3'1" (0.93 m)
Standard Hidden Ballast .....	4,400 lbs (1,995.81 kg)
Overall Length w/o Platform .....	26'6" (8.08 m)
(including Surf Pipe & TAPS plates)	
Overall Length w/ Platform.....	27.5 (8.36 m)
Overall Length w/ Platform & Trailer.....	29'10" (9.09 m)
(trailer tongue extended)	
Overall Length w/ Platform & Trailer.....	28'2" (8.59 m)
(trailer tongue folded)	
Trailer Maximum Width.....	102" (2.59 m)
Trailer Maximum Width.....	106" (2.69 m)
(w/ removable guide poles)	
Height, Alpha E3 Tower Folded w/ Racks (16" Wheels).....	8'8" (2.64 m)
Height, Alpha E3 Tower Folded w/o Racks (16" Wheels) .....	8'6" (2.59 m)
Height, Alpha E3 Tower Up on Trailer (16" Wheels).....	10'10" (3.05 m)
Height, E3+ with SolidShade Tower Folded w Racks.....	8'10.5" (2.71 m)
(16" Wheels)	
Height, E3+ with SolidShade Tower Folded w/o Racks.....	8'9" (2.67 m)
(16" Wheels)	
Height, E3+ with SolidShade Tower Up on Trailer .....	11'3" (3.43 m)
(16" Wheels)	
Weight – Boat & Standard Trailer .....	7,800 lbs (3,538.02 kg)
Weight Capacity .....	2,550 lbs (1,156.66 kg)

*Tigé Boats reserves the right to change specifications, features, color schemes and pricing at any time without notice or incurring obligations. Trailer specifications, weights, details and features may vary depending on options and are subject to change.*



● = Designated Occupant Position

**SPECIFICATIONS Z3**

Length.....	23'5" (7.2 m)
Boat Beam.....	102" (259 cm)
Weight .....	5,350 lbs (2,427 kg)
Ballast.....	3,750 lbs (1,701 kg)
Fuel Capacity.....	57 gal (216 l)
Hull .....	ConvexV
Seating.....	16
Draft.....	29" (74 cm)
Storage.....	118.35 ft <sup>3</sup> (3.35 m <sup>3</sup> )
Freeboard .....	2'11"
Standard Total Ballast.....	3,750 lbs
Standard Hidden Ballast .....	3,400 lbs
Standard Plug & Play Ballast.....	350 lbs
Overall Length w/o Platform (including Surf Pipe & TAPS Plates) .....	24'6"
Overall Length w/ Platform.....	25'5"
Overall Length w/ Platform & Trailer (trailer tongue extended).....	27'10"
Overall Length w/ Platform & Trailer (trailer tongue folded) .....	26'2"
Trailer Minimum Width.....	102"
Trailer Maximum Width (with removable guide poles) .....	106"
Height, Alpha E3 Tower Folded with Racks (16" Wheels).....	8'6"
Height, Alpha E3 Tower Folded with out Racks (16" Wheels).....	8'4"
Height, Alpha E3 Tower Up on Trailer (16" Wheels).....	10'8"
Height E3+ with SolidShade Tower Folded with Racks (16" Wheels).....	8'8.5"
Height E3+ with SolidShade Tower Folded with out Racks (16" Wheels).....	8'7"
Height E3+ with SolidShade Tower Up on Trailer (16" Wheels).....	11'1"
Weight – Boat & Standard Trailer .....	7,000 lbs
Weight Capacity .....	2,275 lbs

*Tigé Boats reserves the right to change specifications, features, color schemes and pricing at any time without notice or incurring obligations. Trailer specifications, weights, details and features may vary depending on options and are subject to change.*



● = Designated Occupant Position

**SPECIFICATIONS Z1**

Length.....	21'5" (6.6 m)
Boat Beam.....	102" (259 cm)
Weight .....	4,860 lbs (2,204 kg)
Ballast.....	3,150 lb (1,429 kg)
Fuel Capacity.....	46 gal (174 l)
Hull .....	ConvexV
Seating.....	14
Draft.....	29" (74 cm)
Storage .....	101.26 ft <sup>3</sup> (2.87 m <sup>3</sup> )
Freeboard.....	2'11"
Standard Total Ballast .....	3,150 lbs
Standard Hidden Ballast .....	2,800 lbs
Standard Plug & Play Ballast.....	350 lbs
Overall Length w/o Platform (including Surf pipe & TAPS plates).....	22'5"
Overall Length w/ Platform.....	23'5"
Overall Length w/ Platform & Trailer (trailer tongue extended).....	25'10"
Overall Length w/ Platform & Trailer (trailer tongue folded) .....	24'2"
Trailer Minimum Width.....	102"
Trailer Maximum Width (with removable guide poles) .....	106"
Height, Alpha E3 Tower Folded with Racks (16" Wheels).....	8'6"
Height, Alpha E3 Tower Folded with out Racks (16" Wheels).....	8'4"
Height, Alpha E3 Tower Up on Trailer (16" Wheels).....	10'8"
Height, Alpha E3+ Tower Folded with Racks (16" Wheels).....	8'8.5"
Height, Alpha E3+ Tower Folded with out Racks (16" Wheels) .....	8'7"
Height, Alpha E3+ Tower Up on Trailer (16" Wheels).....	11'1"
Weight – Boat & Standard Trailer .....	6,500 lbs
Weight Capacity .....	2,040 lbs

*Tigé Boats reserves the right to change specifications, features, color schemes and pricing at any time without notice or incurring obligations. Trailer specifications, weights, details and features may vary depending on options and are subject to change.*





● = Designated Occupant Position

**SPECIFICATIONS 24RZX**

Length.....	24'5" (7.44 m)
Boat Beam.....	102" (259 cm)
Weight .....	6,300 lb (2,858 kg)
Ballast.....	4,000 lb (1,815 kg)
Fuel Capacity.....	80 gal (303 l)
Hull .....	Convex V
Seating.....	18
Draft .....	29" (74 cm)
Storage .....	162.45 ft <sup>3</sup> (4.6 m <sup>3</sup> )
Overall Length with out Platform (Including Surf Pipe & TAPS Plates) .....	25'3"
Overall Length with Platform .....	26'3"
Overall Length with Platform & Trailer (trailer tongue extended).....	30'4"
Overall Length with Platform & Trailer (trailer tongue folded).....	28'4"
Trailer Minimum Width.....	102"
Trailer Maximum Width (with Removable Guide poles).....	106"
Height, Alpha E3 Tower Folded with Racks (18" wheels) .....	8'11"
Height, Alpha E3 Tower Folded with out Racks (18" wheels) .....	8'10"
Height, Alpha E3 Tower Up on Trailer (18" wheels) .....	11'0"
Height, Tower Up on Trailer .....	11'3"
Height, Tower Up on Water .....	7'10"
Height, E3+ with SolidShade Tower Folded with Racks (18" wheels) .....	9'1.5"
Height, E3+ with SolidShade Tower Folded with out Racks (18" wheels) .....	9'1"
Height, E3+ with Solidshade Tower Up on Trailer.....	11'8"
Height, E3+ with Solidshade Tower Up on Water .....	8'3"
Weight - Boat & Trailer (Standard trailer).....	8,000 lbs
Weight Capacity .....	2,234 lbs

*Tigé Boats reserves the right to change specifications, features, color schemes and pricing at any time without notice or incurring obligations. Trailer specifications, weights, details and features may vary depending on options and are subject to change.*



● = Designated Occupant Position

**SPECIFICATIONS 22RZX**

Length.....	22'5" (6.7 m)
Boat Beam.....	102" (259 cm)
Weight .....	5,800 lb (2,631 kg)
Ballast.....	3,400 lb (1,542 kg)
Fuel Capacity.....	57 gal (216 l)
Hull .....	Convex V
Seating.....	16
Draft.....	29" (74 cm)
Storage .....	143.57 ft <sup>3</sup> (4.1 m <sup>3</sup> )
Overall Length with out Platform (Including Surf Pipe & TAPS Plates) .....	23'4"
Overall Length with Platform .....	24'4"
Overall Length with Platform & Trailer (trailer tongue extended).....	28'8"
Overall Length with Platform & Trailer (trailer tongue folded).....	26'9"
Trailer Minimum Width.....	102"
Trailer Maximum Width (with removable guide poles) .....	106"
Height, Alpha E3 Tower Folded with Racks (18" Wheels).....	8'8"
Height, Alpha E3 Tower Folded with out Racks (18" Wheels).....	8'7"
Height, Alpha E3 Tower Up on Trailer (18" Wheels).....	10'9"
Height, Alpha E3 Tower Up on Water .....	7'8"
Height, E3+ with SolidShade Tower Folded with Racks (18" Wheels).....	8'10.5"
Height, E3+ with Solidshade Tower Folded with out Racks (18" Wheels) .....	8'10"
Height, E3+ with SolidShade Tower Up on Trailer (18" wheels) .....	11'2"
Height, E3+ with SolidShade Tower Up on Water .....	8'1"
Weight - Boat & Trailer (Standard trailer).....	7,500 lbs
Weight Capacity .....	2,150 lbs

*Tigé Boats reserves the right to change specifications, features, color schemes and pricing at any time without notice or incurring obligations. Trailer specifications, weights, details and features may vary depending on options and are subject to change.*



● = Designated Occupant Position

**SPECIFICATIONS 20RX**

Length.....	20' (6.1 m)
Boat Beam.....	102" (259 cm)
Weight .....	4,975 lb (2,257 kg)
Ballast.....	3,000 lb (1,360 kg)
Fuel Capacity.....	46 gal (174 l)
Hull .....	Convex V
Seating.....	13
Draft.....	29" (74 cm)
Storage .....	85.75 ft <sup>3</sup> (2.43 m <sup>3</sup> )
Freeboard .....	3'0"
Standard Total Ballast .....	3,000 lbs
Standard Sub-Floor Ballast .....	1,900 lbs
Standard Plug & Play Ballast.....	1,100 lbs
Overall Length with out Platform .....	20'0"
Overall Length with Platform .....	22'1"
Overall Length with Platform & Trailer (trailer tongue extended).....	26'2"
Overall Length with Platform & Trailer (trailer tongue folded).....	24'2"
Trailer Minimum Width.....	102"
Trailer Maximum Width (with removable guide poles) .....	106"
Height, Tower Folded with Racks (18" Wheels) .....	8'4"
Height, Tower Up on Trailer .....	10'7"
Height, Tower Up on Water .....	7'0"
Height, E3+ with SolidShade Tower Folded with Racks (18" Wheels).....	8'6.5"
Height, E3+ with SolidShade Tower Folded with out Racks (18" Wheels).....	8'6"
Height, E3+ with SolidShade Tower Up on Trailer .....	11'
Height, E3+ with SolidShade Tower Up on Water .....	7'5"
Weight - Boat & Trailer (Standard trailer).....	6,475 lbs
Weight Capacity .....	1,950 lbs

*Tigé Boats reserves the right to change specifications, features, color schemes and pricing at any time without notice or incurring obligations. Trailer specifications, weights, details and features may vary depending on options and are subject to change.*



● = Designated Occupant Position



## 2023 TIGÉ LIMITED WARRANTY

Tigé Boats, Inc. provides limited warranty coverage on its products sold for use by retail (non-commercial) customers as described in this Limited Warranty. Your dealer must submit the warranty registration of your boat to Tigé Boats, Inc. for your Limited Warranty to be in effect. Limited Warranty coverage begins on the date you take delivery, or initial use of the boat, whichever first occurs, and applies to defects in factory materials and workmanship which first arise and are reported to Tigé Boats, Inc. within the applicable warranty period. This warranty gives you specific legal rights, and you may also have other rights which vary from state to state.

This Limited Warranty extends to the first retail customer but can be partially transferred to a second owner following Tigé’s warranty transfer procedures. A change in the principals of any entity owning a boat will be deemed a “transfer” under this Limited Warranty. Engine and trailer warranties must be transferred separately (directly with those manufacturers).

This Limited Warranty is the sole and exclusive warranty provided by Tigé Boats, and ALL IMPLIED WARRANTIES AND CONDITIONS, INCLUDING ANY IMPLIED WARRANTY OF MERCHANTABILITY OR FITNESS FOR A PARTICULAR PURPOSE, ARE EXCLUDED AND DISCLAIMED (OR LIMITED) TO THE FULLEST EXTENT ALLOWED BY APPLICABLE LAW. Engines, transmissions/powertrain and trailers are separately warranted by the component manufacturers, and you should refer to the warranties of those component manufacturers for details regarding warranty coverage. To the extent that any implied warranties are required by applicable law, any implied warranties are limited to the duration of the applicable provisions of this Limited Warranty. Some states do not allow limitations on how long an implied warranty lasts, so the above limitation may not apply to you.

### Limited Warranty Coverage Summary

COVERAGE TYPE	COVERAGE PERIOD
Structural Limited Warranty	Lifetime
Base Limited Warranty – Fresh Water Boats	Sixty (60) months or 500 hours, whichever first occurs
Base Limited Warranty – Salt Water Boats	Thirty-six (36) months
Gel Coat, Powder and Other Finishes Limited Warranty	Twelve (12) months
Upholstery Limited Warranty	Thirty-six (36) months

The repair and/or replacement of components or parts under warranty does not extend the warranty period beyond the original expiration date.





Structural Limited Warranty. For the life of the boat (original retail purchaser only), Tigé Boats will repair or replace structural materials or structural workmanship supplied by it during the construction of the hull, deck, floor liner, or stringer, which are determined by Tigé Boats to contain substantial (non-cosmetic) manufacturing defects. This Structural Limited Warranty does not apply to the Tigé Boats' gel coat or powder coat (see below for Gel Coat & Powder Coat Limited Warranty), or any cosmetic aspects of the hull, deck, liner, or stringer. The entirety of the structural warranty is limited to the specific laminates or bonding of laminates for the hull, deck, floor liner, or stringer only.

Base Limited Warranty. During the applicable Base Limited Warranty period Tigé Boats will repair or replace materials or workmanship supplied by it during construction of the Tigé Boat, including parts and labor, which are determined by Tigé Boats to contain substantial manufacturing defects.

This Limited Warranty does not provide coverage for any component part that is at any time covered by any warranty provided by any third party, other than Tigé Boats, including, but not limited to the manufacturer of the component part. Component parts shall include, but are not necessarily limited to, any items that are fastened to the boat through either mechanical means (screws/bolts) or chemical means (adhesives), which may or not be manufactured by Tigé Boats. Some examples of component parts include displays, carpet, floor panels, upholstery substrates and bases, etc. In the event that any warranty coverage for any component part is rendered or deemed void due to actions of the Purchaser or any third party other than Tigé Boats, this Limited Warranty will not provide warranty coverage for the component part.

Gel Coat, Metal Flake, Powder Coat, Other Finishes, and Upholstery Limited Warranty. Maintenance of all gel coat, metal flake, powder coat and other finishes, as well as all upholstery, is the Purchaser's responsibility, and limited warranty coverage is conditioned on the Purchaser providing and performing all maintenance and care described in the Owner's Manual. During the applicable warranty period, Tigé Boats will repair materials or workmanship supplied by it which are determined by Tigé Boats to contain substantial manufacturing defects. Note: Minor distortions, manufacturing variations, or imperfections in the gel coat, metal flake, or other finishes are considered normal and unavoidable.

Limited Warranty Coverage Exclusions and Limitations. In addition to any other limitations and exclusions, the following are NOT covered under this Limited Warranty:

- Normal maintenance and wear and tear, including sun exposure, water damage (including damage to items stored in glove boxes or other storage compartments), the use of non-specified (see Owner's Manual) lubricants, gasoline or other fluids, environmental and other damage to gel coat, metal flake or other finishes (whether due to salt water or other conditions), and upholstery cracking, mold, mildew, stains, fading or tears.



# INTRODUCTION

- Damage caused by the failure to provide proper maintenance, care (including winterization), and repairs (including complying with all service bulletins and notices), as well as the use of non-factory authorized components, mooring covers, service techniques (including any unauthorized disconnection, disturbance or compromise of any wires, hoses, tubes, cables, looms or other factory-installed electrical or fuel systems), or the use of improper cleaning or maintenance products. Note: proper and complete records should be kept of all maintenance and repairs to your boat, and Tigé Boats reserves the right to limit or decline warranty repairs if proper records have not been maintained or are not available to Tigé Boats upon request.
- Warranty or other repairs which are not pre-authorized by Tigé Boats, or which are provided by a non-Tigé service provider.
- Blistering, discoloration, scratching, and cracks of any gel coat, metal flake, powder coat or other finishes, including any damage resulting from the failure to apply marine-grade hull paint on boats that are allowed to remain in bodies of water for extended periods (more than 14 days).
- Damage caused by accident, impact or collision, speeding, acts of nature, abuse, misuse, and similar boating activities, negligence, environmental or natural conditions, or any use in violation of any federal, state, local, Coast Guard or other governmental agency law, rule, or regulation.
- Component parts that are covered by any warranty provided by the part manufacturer or any third party. Component parts include, but are not necessarily limited to, engines, transmissions/powertrains, trailers, any items that are installed into the boat, or fastened to the boat through either mechanical means (screws/bolts) or chemical means (adhesives), such as displays, carpet, floor panels, upholstery substrates and bases, whether or not installed or added by ATX Surf Boats. ATX Surf Boats does not provide warranty coverage on these components under any circumstances. (Note: to the extent applicable to any component, it is the owner's responsibility to complete any warranty registration process (or any warranty transfer process for any subsequent owner) required to obtain/maintain warranty coverage for these components).
- The addition or use of any components (including dealer-supplied factory or non-factory components such as surf systems and trim plates), the modification of any factory components, or any other alteration or modification of the boat, including but not limited to aftermarket towers, tower accessories, ballast systems, barefoot booms, canvas accessories, and hull bottom painting.
- Damage or corrosion, including oxidation, loss of colorfastness of finish, or electrolysis affecting chrome plated, metal flake, stainless, anodized, aluminum or other finishes. Note: failure to follow the instructions in the Owner's Manual regarding corrosion prevention and operation may cause or contribute to these types of damage, which are not covered by this Limited Warranty.



- Damages caused by improper support of the boat on davits, hoist systems or boat lifts of any kind.
- The use of a trailer not supplied by Tigé Boats with the boat, or improper trailering.
- Damages caused by improper weight distribution, or excessive weight combinations (persons and equipment), or improper use of ballast systems, or simulated ballast and gear.
- Damages caused by water intrusion into any part of the boat (including, but not limited to, the glove box and various storage compartments, and the intake or exhaust systems);
- Performance characteristics, such as speed, acceleration, fuel or oil consumption, etc., as they are estimated and can vary depending on individual conditions.
- The following will void this limited warranty in its entirety:
  - Use of the boat for commercial (including boat sharing or peer-to-peer rentals), ski or wakeboard schools or shows, demonstration or promotional purposes, racing or non-recreational activities or purposes.
  - Use of the boat in salt water without the saltwater option package.
  - The addition of a surf system, trim plate or any similar component not installed by Tigé Boats at the time of manufacture. **Note: the addition of these components may affect the safe use and handling of the boat.**
  - The unauthorized disabling of any components, including any warning device or system, installed in any Tigé Boat.
  - No limited warranty coverage applies to any boat which has been determined to be a total loss or salvage vessel as a result of any collision, accident or other occurrence.

Transfer of Warranty. Subject to the above limitations and exclusions, for the first sixty (60) months following the date on which the original retail purchaser took delivery of, or first used, the boat, this Limited Warranty may be transferred to a second non-commercial owner, except that (1) structural limited warranty coverage is not fully transferrable (see transfer form); and (2) the transfer of this warranty does not extend the term of any warranty coverage period (which shall run from the original delivery or use of the boat). All other Limited Warranty coverage will remain in effect, subject to the exclusions, conditions and requirements set forth in this Limited Warranty.

Only one transfer is allowed, and other transfer conditions and requirements may apply. You must contact Tigé Boats (see below) within twenty (20) days of the sale of the boat to initiate this transfer process. Engine, trailer and other component warranties must be transferred separately (directly with those manufacturers).



### Remedies Under this Limited Warranty

For any defect covered by this limited warranty, Tigé Boats (directly or through an authorized dealer or designated repair facility, as determined by Tigé Boats) will repair or replace the defective component, as determined in its sole discretion. This “repair or replacement” remedy is the sole and exclusive remedy under this limited warranty. Tigé Boats has no responsibility or liability for any incidental or consequential damages, such as loss of use, storage charges, interest or finance charges, insurance or depreciation, transportation or lodging expenses, or charges for towing or hauling out, all of which are EXCLUDED AND DISCLAIMED FROM THIS WARRANTY. Some states do not allow the exclusion or limitation of incidental or consequential damages, so the above limitation or exclusion may not apply to you.

### Responsibility of Purchaser

Although your Tigé Boats dealer is responsible for completing all pre-delivery work, you should carefully inspect your Tigé Boats boat and trailer before taking delivery. Defects and/or damage to the finish surfaces, trim, upholstery or other observable cosmetic components of your Tigé Boat may occur during production. These items are usually detected and corrected prior to shipment to the dealership or by the retail dealer prior to delivery to the retail customer. Nonetheless, consumers are encouraged to inspect the Tigé Boat for this type of damage prior to taking delivery, and all such defects or damage must be reported to the retail Tigé Boat dealer at the time of delivery to have any items covered by this Limited Warranty addressed, and to have any covered defects repaired at no cost to the Purchaser. Tigé Boats may decline or limit warranty coverage on any such defects which were not timely reported by the retail customer.

All warranty registration and other delivery documents should be completed at the time of delivery, and you must warranty register your Tigé Boat (and all components warranted by other manufacturers) at the time of delivery.

Tigé Boats strongly encourages all owners to carefully review the Owner’s Manual (and the manuals for all components) and follow all maintenance and use instructions. Detailed service records must be maintained.

### Obtaining Warranty Service

In the event you need warranty service, you should immediately contact the Tigé Boats dealer from which you purchased the boat or an authorized Tigé Boats dealer. Certain repairs require Tigé Boat’s pre-approval. If your dealer does not promptly resolve the warranty issue (or if the selling dealer is unavailable), you should contact Tigé Boats directly at the address below. Tigé Boats is not responsible for unreported defects.



The boat, including any component part for which warranty service is requested, must be returned to an authorized Tigé Boats dealer (or as otherwise directed by Tigé Boats) for repairs, within the warranty period. The expense of transporting the boat (or any component part) to and from an authorized Tigé Boats dealer or other designated repair facility is your responsibility and will not be reimbursed.

### Other Information

This is the sole and exclusive Limited Warranty provided by Tigé Boats, and this Limited Warranty can only be modified by written agreement signed by Tigé Boats' president. Your Tigé Boats dealer is an independent business and is not the agent of Tigé Boats under this Limited Warranty or for any other purpose. Tigé Boats reserves the right to implement changes in the construction or components of any Tigé Boat at any time, without incurring any obligation to make the same or similar changes on Tigé Boats previously built and/or sold.

Tigé Boats may be contacted as follows:

Tigé Boats, Inc.  
1801 Hwy 36  
Abilene, TX 79602  
Phone: 325.676.7777  
info@Tigé.com

## **AUSTRALIAN CONSUMERS ONLY**

Warranty claims under this Limited Warranty may be sent to Wake Apac Pty Ltd., 70 Meroo Rd, Bomaderry NSW PO Box 2131 Bomaderry, NSW, Australia 2541 (Tel: +6 1800 950 736) [service@wakeapac.com](mailto:service@wakeapac.com)

The benefits to the consumer given by this Limited Warranty are in addition to other rights and remedies of the consumer under a law in relation to the goods to which the warranty relates.

This Limited Warranty does not cover any expenses that you may incur claiming the warranty.

Our goods come with guarantees that cannot be excluded under the Australian Consumer Law. You are entitled to a replacement or refund for a major failure and compensation for any other reasonably foreseeable loss or damage. You are also entitled to have the goods repaired or replaced if the goods fail to be of acceptable quality and the failure does not amount to a major failure.



SECTION

**1**

# INTRODUCTION

This Page Intentionally Left Blank

# Section 2

## SAFETY

The popularity of boating and other water sports has undergone an explosion of growth in the past few years, making safety an important issue for everyone who shares in the use of the waterways.

 **WARNING** *Operation Hazard: Read and understand this Basic Boating and Safety Manual, the Engine Operator's Manual and all manufacturer-supplied information regarding the operation of equipment. The boat operator must understand all safety information responsibilities, regulations, controls and operating instructions before attempting to operate the boat. Improper operation could result in death or serious injury.*

The safety content and precautions listed in this manual and on the boat are not all-inclusive. If a procedure, method, tool or part is not specifically recommended, the operator must feel confident that it is safe for them and others, and that the boat will not be damaged or become unsafe as a result of the operator's decision.

**REMEMBER – ALWAYS ASSESS EACH SITUATION AND USE SOUND JUDGMENT!**

The boat operator is responsible for their own safety, as well as that of passengers and other boaters.

### GOOD BOATING PRACTICES

Boating-related accidents are generally caused by the operator's failure to follow basic safety rules or written precautions. Most accidents can be avoided if the operator is completely familiar with the boat, its operation and the navigational rules of the road and can recognize potentially hazardous situations.

In addition to everyday safety, failure to observe safety recommendations may result in severe personal injury or death to the operator or to others. Use caution and sound judgment when operating the boat. Do not take unnecessary chances! Failure to adhere to these warnings could result in death or severe injury to the operator and/or others.



Read this entire manual and be aware of other specific safety guidelines not listed in this manual. Seek additional safety information from the USCG and state and local authorities. In addition to specific safety statements noted in this manual, a general list of safety guidelines and recommendations is listed below:

- The boat must comply with USCG safety equipment regulations.
- Before each outing, check all safety equipment such as fire extinguishers, life jackets, flares, distress flags, flashlights and engine emergency stop switch. Make sure they are operable, in good condition, readily visible and easily accessed.
- Onboard equipment must always conform to the governing federal, state and local regulations.
- Never allow any type of spark or open flame on board. It may result in fire or explosion.
- Take the keys/FOBs when leaving the boat to keep untrained and unauthorized persons from operating the boat.
- Know how to react correctly to adverse weather conditions, have good navigation skills and follow navigational rules as defined by USCG, state and local regulations.
- Check local weather reports before casting off. Do not leave the dock area when strong winds and electrical storms are in the area or predicted to be in the area.
- Seek shelter from open water if lightning is an imminent threat.
- Tell someone of the travel plans before departing.
- Know the weight capacity of the boat. Never overload the boat.
- Never operate the boat while under the influence of drugs or alcohol.
- Look before turning the boat. The boater is obligated to maintain a course and speed unless it is safe to alter course and speed. Look before turning.
- Operators must read and understand all operating manuals supplied with the boat before operation.
- Whenever planning an outing, make sure that at least one passenger is familiar with the operation and safety aspects of the boat in case of emergency.
- Passengers should never sit in front of the operator; always avoid obstructing the operator's view.
- Show all passengers the location of emergency equipment and explain how to use it.
- Never allow passengers to drag their feet or hands in the water, or sit on the bow, bow pulpit, railing, deck or gunwale while the engine is running.
- Never use or hold on to the boarding platform while the engine is running.
- Never stand or allow passengers to stand in the boat or sit on the transom, seat backs, engine cover or sides of the boat while the engine is running. The operator or others may be thrown from the boat.





- Children and nonswimmers must wear a life jacket at all times.
- Never leave children in the boat without adult supervision.
- Improper operation of the boat is extremely dangerous.
- Securely attach the engine emergency stop switch lanyard around your leg or to a part of your clothing such as a belt loop, when operating the boat. Instruct others on how to start the boat if you as an operator are thrown overboard. Consider having an extra lanyard readily available on board since the system cannot be overridden without the lanyard that is on the person who is now overboard.
- Operate slowly in congested areas such as marinas and mooring areas.
- The bow may be slippery. Do not go forward while the engine is running.
- Slow down when crossing waves or wake in order to minimize the impact on passengers and the boat.
- Never replace the boat's marine parts with automotive parts (if applicable).
- Never remove or modify any components of the fuel system. Always have qualified personnel perform fuel system maintenance. Tampering with fuel components may cause a hazardous condition.
- Avoid contact with engine exhaust gases—engine exhaust contains carbon monoxide.
- Never operate the engine in a confined space.
- Never go under the boat cover with the engine running or shortly after the engine has been running.
- Allow adequate ventilation with fresh air before entering any enclosed areas.
- Watch for other boats, swimmers and obstructions in the water. Stay away from other boats and personal watercraft (PWCs).
- Never swim near a boat when the engine is running. Even if the boat is in the NEUTRAL position, the propeller may still be turning and carbon monoxide may be present.
- Never dive from the boat without being absolutely sure of the depth of the water; severe injury or death may occur from striking the bottom or submerged objects.
- Never wrap ski lines or mooring lines around any body part. You could become entangled in the line if you fall overboard while the boat is moving.
- Keep track of ski lines and dock lines so they do not become entangled in the propeller.
- Have an experienced operator at the helm and always have at least three people present for safe towing—one to drive, one to observe, and one to ski or ride.



## SAFETY AND TRAINING

There is a vast amount of recreational boating regulatory, safety and training information online, and much of it is free. This information covers laws, aids to navigation, rules of the road, hands-on boating safety courses, boat safety checks and much more for both novices and experienced boaters. Go to the following sites for more information:

- United States Coast Guard  
[www.uscgboating.org](http://www.uscgboating.org)
- United States Power Squadron  
[www.usps.org](http://www.usps.org)
- BoatU.S. Foundation  
[www.boatus.org](http://www.boatus.org)

## STRONG POINTS

Your boat is equipped with designated strong points that are designed to support the weight of the boat and engine for lifting the boat from the water. Additionally, only strong points should be used for towing another boat or towing an inflatable tube. Never use cleats and/or ski tow pylons for lifting or towing.

## SAFETY LABELS

The boat is affixed with various hazard and safety labels at the time of manufacture. These labels appear in specific locations on the boat and on equipment where safety is of particular concern. All operators of the boat must read and understand all hazard and safety labels and advise all passengers on the safety concerns and proper practices. Hazard and safety labels must remain legible. If the operator suspects a label is missing or damaged they should contact the dealer for replacement.



## SAFETY STATEMENTS

There is no substitute for sound judgment and careful practices. Improper practices or carelessness can cause burns, cuts, mutilation, asphyxiation, other bodily injury or death. This information contains general safety precautions and guidelines that must be followed to reduce risk to personal safety. Special safety precautions are listed in specific procedures. Read and understand all of the safety precautions before operation or performing repairs or maintenance.



NOTE — This safety alert symbol appears with most safety statements. It means attention, become alert, your safety is involved! Please read and abide by the message that follows the safety alert symbol.



### **DANGER**

*Indicates a hazardous situation that, if not avoided, will result in death or serious injury.*



### **WARNING**

*Indicates a hazardous situation that, if not avoided, could result in death or serious injury.*



### **CAUTION**

*Indicates a hazardous situation that, if not avoided, could result in minor or moderate injury.*

### **NOTICE**

*Indicates a situation that can cause damage to the boat and accessories and/or the environment, or cause the equipment to operate improperly.*



## SAFETY PRECAUTIONS



### **DANGER**

The safety messages that follow have **DANGER** level hazards. These safety messages describe hazardous situations that, if not avoided, will result in death or serious injury.



**Training Hazard:** Do not permit anyone to launch, operate or retrieve the boat without proper training.

- Read and understand this Basic Boating and Safety Manual and all manufacturer-supplied information before operating or servicing the boat to ensure that you follow safe operating practices and maintenance procedures.
- Safety signs and labels are additional reminders for safe operating and maintenance techniques.
- See the boat dealer for additional training.



**Exhaust Hazard:** Carbon monoxide (CO) is a colorless and odorless gas produced by all engines, fuel-burning appliances and any material that contains carbon and is burned. Direct or prolonged exposure to carbon monoxide will cause brain damage or death.



**Electrocution Hazard:** Docks and other boats nearby can carry sources of electricity. Faulty wiring or the use of damaged electrical cords and other devices not approved as “shore or marine rated” can cause the surrounding water source to become energized from electricity leakage. Never enter the water or swim in a marina.



### **WARNING**

The safety messages that follow have **WARNING** level hazards. These safety messages describe hazardous situations that, if not avoided, could result in death or serious injury.



**Fire/Explosion Hazard:** Gasoline is extremely flammable and highly explosive under certain conditions.

- Compartments for fuel, flammable liquids or gases must be properly ventilated to prevent explosive vapors from accumulating. Most vapors are heavier than air. If not in a vapor-tight locker vented overboard, vapors will accumulate in the bilge, posing a fire and explosion hazard.
- Inspect fuel system for leaks at least once a year.



**Fire/Explosion Hazard:** Hydrogen gases produced by a lead-acid battery while it is charging, or the engine is running, can cause an explosion and/or a fire.

- Always wear personal protective equipment when working on or around batteries.
- Keep the area around the battery well-ventilated.
- Do not smoke or bring an open flame or any other form of ignition near a battery.
- Do not check for a dead battery by placing a metal object between the battery posts. Sparks could cause an explosion.
- Do not place your head directly above a battery when making or breaking electrical connections.
- Always charge the battery outside of the boat.
- Do not use a battery booster to start the engine.



**Sever Hazard:** Make sure nobody is near the propeller before starting the engine(s).

- Do not allow swimmers to approach or use the ladder when the engine is running.
- The operator should walk to the stern and check the water for people near the propeller, as people in the water may not always be noticeable from the helm.
- Turn off the engine(s) before allowing people to board or exit the boat. The propeller may continue rotating even when the engine is idling or in NEUTRAL.
- Show passengers the location of the propeller and teach them to keep their distance from it at all times, even when the propeller is not in motion.
- Show passengers the propeller warning labels around the boat and discuss propeller dangers.
- Be particularly alert when boating in high-traffic areas and never operate in swimming zones.
- Exercise caution when operating near boats that are towing skiers and tubers.
- Never allow passengers to sit in areas where they could fall overboard, including the bow, gunwale, transom, seat backs, or other locations.



- **Carefully watch children aboard the boat at all times.**
- **Instruct passengers on the rules for using the swim platform, boarding ladders and seats. If possible, instruct them to stay seated at all times while the engine is running.**



**Man Overboard Hazard:** Always remain seated in the boat manufacturer's designated seating arrangement, use handholds and never block the view of the boat operator while underway. The boat's bow, gunwale, transom platform and seat backs are not intended for use while underway.

- **If someone falls overboard, slowly turn the boat around while keeping an eye on the victim. Ask a passenger to help monitor the victim. Always STOP THE ENGINE before rescuing a victim from the water.**
- **Never put the engine in REVERSE to retrieve a person from the water. Slowly circle back to the person again if necessary.**



**Entanglement Hazard:** Rotating or moving parts can entangle or sever body parts.

- **Do not wear jewelry, unbuttoned cuffs, ties or loose-fitting clothing.**
- **Tie long hair back when working near moving or rotating parts such as the flywheel or propeller shaft.**
- **Keep hands, feet and tools away from all moving parts.**
- **Keep all guards in place when the engine is operating.**
- **Use caution when working with ski or mooring lines so they do not become entangled with the propeller.**



**Exposure Hazard:** Wear personal protective equipment, including appropriate clothing, gloves, work shoes, eye and hearing protection, as required by the current task.



**Control Hazard:** Do not operate the boat while you are under the influence of alcohol or drugs or if feeling ill. Federal laws prohibit operating a boat under the influence of alcohol or drugs. These laws are vigorously enforced.

**CAUTION**

*The safety messages that follow have CAUTION level hazards. These safety messages describe hazardous situations that, if not avoided, could result in minor or moderate injury.*



*Slip/Trip Hazard: Keep the boat free of water, oil, mud and other foreign matter. Do not wax deck and swim platform surfaces. Remove anything that creates slippery areas around the boat.*

**NOTICE**

*The safety messages that follow have NOTICE level hazards. These messages are used to indicate a situation that can cause damage to the boat and accessories and/or the environment, or cause the equipment to operate improperly.*

- *Unapproved modifications to the boat or systems may impair the boat's safety and performance characteristics and shorten the boat's life. Any alterations to the boat may void its warranty. Always consult the boat manufacturer before making modifications or adding equipment.*
- *ALWAYS be environmentally responsible. Follow the guidelines of the EPA or other governmental agencies for the proper disposal of hazardous materials such as engine oil and fuel. Collect all trash and dispose properly on shore. Keep our waters clean! Consult the local authorities or reclamation facility.*



## Carbon Monoxide (CO)



### DANGER

**Exhaust Hazard: CO gas is colorless, odorless and extremely dangerous. All engines and fuel-burning appliances produce CO as exhaust. Direct and prolonged exposure to CO will cause brain damage or death. Always avoid exposing your passengers or yourself to CO.**

Even with the best boat design and construction, plus the utmost care in inspection, operation and maintenance, hazardous levels of CO may still be present in accommodation areas under certain conditions. To reduce CO accumulation, always provide adequate ventilation in the boat interior by opening the deck hatches, windows or canvas.

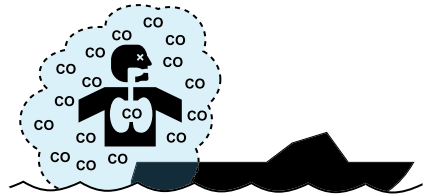

Do not confuse carbon monoxide poisoning with seasickness, intoxication or heat stress. If someone complains of irritated eyes, headache, nausea, weakness, dizziness or drowsiness, or you suspect carbon monoxide poisoning, immediately move the person to fresh air, investigate the cause and take corrective action. Seek medical attention if necessary.

Always use a CO detector in confined areas where there is a possibility of CO buildup, such as enclosed canvas, sleeping quarters, galleys and head compartments. Regularly check the condition of the CO detector for proper operation.

Make sure that all passengers know what the CO detector alarm sounds like. If the alarm sounds, shut down engines and generator, move passengers to fresh air for at least 10 minutes, reset the alarm and investigate the cause. Ventilate the space thoroughly before restarting engines and generator.

Test the carbon monoxide detector operation before each trip, at least once a week and after the boat has been in storage. Also have the CO detectors professionally tested at regular intervals. Most CO detectors are required to be replaced every 5 years – see the OEM manual.





## Potential Causes of CO Poisoning While Under Way

Blockage of boat exhaust by obstruction

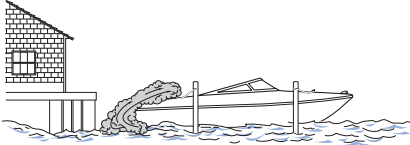

KC-0233-A

Exhaust from other vessels in confined areas



KC-0307-A

Operating at a high bow angle



KC-0234-A

Operating at slow speed or while idling



KC-0235-A

Exhaust traveling along obstruction

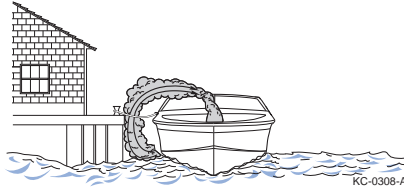

KC-0308-A

**Always ensure adequate fresh air ventilation through the boat when under way.**



KC-0236-A

KC-0301-B



## OVERLOADING

 **WARNING** *An overloaded boat through passengers, non-factory installed ballast, and equipment can cause death or serious injury. It can cause loss of control, capsizing, or swamping.*

**DO NOT overload your boat.** Your boat is equipped with a maximum capacity plate indicating the maximum acceptable load as determined by the manufacturer following certain Federal guidelines. Equally critical is how weight is distributed throughout the boat. The weight must be distributed evenly throughout the boat, besides the proper use of the ballast. If too much weight is placed in one area it can have serious impact on boat handling and control.

The capacity plate is used by boat manufacturers participating in the National Marine Manufacturers Association certification program. Your manufacturer has submitted your model for inspection and compliance with their guidelines. The capacity plate has the following information permanently printed on it. It is attached to the boat by the throttle for the operator to read before they drive the boat.

- The total weight of persons, gear and other items which the boat is capable of carrying under normal conditions. **This weight must include any added ballast above and beyond manufacturer's ballast system(s).**

### ***Be Advised***

- Any non-factory installed ballast must be properly secured to prevent injury. Non-factory ballast is not recommended.
- Death or serious injury can occur from overloading the boat. **DO NOT** overload your boat.
- Do not fill the bilge area with water from any source.
- The maximum number of persons allowed on the boat. This information on the capacity plate applies under normal conditions and special care must be used in any abnormal conditions. Check the capacity plate on your boat and abide by these limits.
- Remember **DO NOT** exceed capacity!

### ***NOTICE***

*Your boat manufacturer installs wake enhancement ballast systems in some models. The full weight of this system has already been considered in the boat capacity calculation and therefore does not influence maximum capacity, unlike non-factory ballast tanks or weights, which must be included as part of the gear weight.*



As wakeboarding has developed, we have witnessed the advent of ballast systems which add weight and increase the size of the wake. The simplest ballast system on the market is the water ballast type, such as the “FAT SAC.” It is not uncommon to see operators use such systems and then put additional people in their boat. Please be advised that this practice can lead to overloading your boat. Each boat has a maximum capacity label displaying the maximum weight of people, gear and ballast that can be placed in the boat. Always be aware of the load in your boat and do not load the boat in excess of the listed capacity. The quest for the largest wake has caused some to excessively overload their boats.

Overloading a boat may cause it to become unstable and adversely affect the boat’s handling.

**REQUIRED BOATING SAFETY EQUIPMENT AND REGULATIONS**

**U.S. Coast Guard Minimum Onboard Safety Equipment Required**  
**(Your boat may be equipped with one or more requirements by the**  
**manufacturer, but it is the boat owner's responsibility to have these items**  
**on board.)**

	LESS THAN 16 FT (4.9 M)	CLASS 1: 16 TO LESS THAN 26 FT (4.9 TO LESS THAN 7.9 M)	CLASS 2: 26 TO LESS THAN 40 FT (7.9 TO LESS THAN 12.2 M)	CLASS 3: 40 TO 65 FT (12.2 TO 19.8 M)
<b>LIFE JACKETS AND PERSONAL FLOTATION DEVICES (PFDs)</b>	One U.S. Coast Guard-approved wearable life jacket for each person on board	One U.S. Coast Guard-approved wearable life jacket for each person on board and one throwable PFD device		
<b>VISUAL DISTRESS SIGNALING (VDS) DEVICES</b>	One (1) electric distress light OR three (3) day and night combination red flares	One orange distress flag or one electric distress light OR three floating or handheld orange smoke signals and one electric distress light OR three day and night combination red flares, handheld, parachute or meteor type		
<b>AUDIBLE SIGNALING DEVICES</b>	A boat less than 39.4 ft (12 m) must have on board an efficient sound-producing device. (Example: hand or mouth whistle OR a compressed or powered air horn)		A boat 39.4 ft (12 m) but less than 65.6 ft (20 m) in length operating in inland waterways must carry a power whistle OR powered air horn AND a bell	
<b>NAVIGATION LIGHTS</b>	Regulations require that navigational lights be clearly lit and properly displayed at all times between sunset and sunrise and always when operating in reduced visibility while boating			



	LESS THAN 16 FT (4.9 M)	CLASS 1: 16 TO LESS THAN 26 FT (4.9 TO LESS THAN 7.9 M)	CLASS 2: 26 TO LESS THAN 40 FT (7.9 TO LESS THAN 12.2 M)	CLASS 3: 40 TO 65 FT (12.2 TO 19.8 M)
<b>FIRE EXTINGUISHERS</b>	<p>One 5-B type (U.S. Coast Guard-approved)</p> <p>If the boat meets any one or more of the following conditions, the boat must carry one 5-B type USCG-approved extinguisher on board:</p> <ul style="list-style-type: none"> <li>• Inboard/sterndrive engine powered</li> <li>• Has closed compartments where portable fuel tanks can be stored</li> <li>• Has double bottom construction that has areas where air or gases can be open or trapped</li> <li>• Has an enclosed living space</li> <li>• Has compartments where flammable, combustible or explosive materials are stored</li> <li>• Has permanent fuel tanks installed</li> <li>• Boat is 26 ft (7.9 m) or more in length</li> </ul>	<p>One 20-B OR two 5-B type (USCG-approved) (A fixed extinguishing system is equal to one 5-B.)</p>	<p>One 20-B AND one 5-B OR three 5-B type (USCG-approved) (A fixed extinguishing system is equal to one 5-B.)</p>	
<b>EMERGENCY ENGINE STOP SWITCH</b>	<p>Powered boats less than 26' (7.9 m) operating in Federal waters must be equipped with an engine stop switch and operator interface.</p>			



## FIRE EXTINGUISHER

USCG-approved fire extinguishers are required on all Class I, II and III boats. Mount all handheld fire extinguishers in readily accessible areas away from the engine compartment and other combustible devices. All passengers must know the location and operating procedure of each extinguisher. Follow the manufacturer's instructions for proper use and operation of the fire extinguisher.

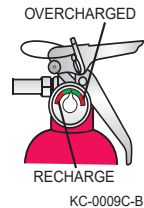

All fire extinguishers used on marine boats must be classified to extinguish type B fires (gasoline, oil or grease). The size and number of required fire extinguishers depend on the size of the boat. The two type B fire extinguishers commonly used are 5-B and 20-B. Type B fire extinguishers are classified by the different extinguishing compound amounts used in each.

Check the fire extinguisher condition and pressure gauge regularly, if not before every trip, to ensure that the fire extinguisher is in good operating condition and is fully charged. If the fire extinguisher is damaged or not properly pressurized, replace it. Disposable (non-rechargeable) fire extinguishers with a date of manufacture stamped on the bottle older than 12 years must be removed from service and no longer count towards the minimum carriage requirements.

See the *U.S. Coast Guard Minimum Onboard Personal Safety Equipment Required* section of this manual for specific onboard requirements.

## ENGINE EMERGENCY STOP SWITCH AND LANYARD

The engine emergency stop switch is an extremely important safety device. Use the engine emergency stop switch when operating the boat's engine. This safety device prevents the boat from becoming a runaway if the operator is accidentally thrown from the seat or away from the helm. The USCG recommends and many states require the use of the emergency stop switch by law. Check with local and state authorities about usage requirements to avoid potential fines.

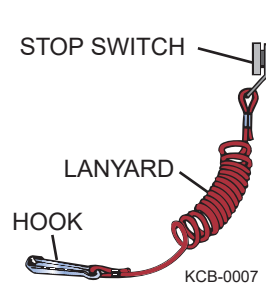

Starting April 1, 2021, individuals operating most types of powered boats less than 26' (7.9 m) in Federal waters are required to use an engine emergency stop switch and lanyard while the boat is on plane or above displacement speed.



- Tiller-steered models may have a switch mounted on the tiller handle with a wrist lanyard.
- Side-mount controls may have a switch on the control box with a “clip-on” lanyard.
- Larger boats may have a helm-mounted switch with a “clip-on” lanyard.
- Some boats may have a wireless switch with a FOB attached to the operator. Consider having an extra lanyard readily available on board since the system cannot be overridden without the lanyard that is on the person who is now overboard.

**WARNING**

**Control Hazard: Never remove or modify the engine emergency stop switch and/or lanyard.**

- ***Always check the switch for proper operation. With the engine running in neutral, pull the lanyard. If the engine does not stop, have the switch repaired before continuing to operate the boat. Never operate the boat if the engine emergency stop switch does not work.***
- ***Avoid accidentally pulling the cord lanyard during normal operation. Loss of engine power means loss of most steering control. Also, without engine power, the boat could slow rapidly. This could cause people and objects in the boat to be thrown forward.***

## LIFE JACKETS

Boaters enjoy the feel of sun and spray, so it’s tempting to boat without wearing a life jacket, especially on nice days. However, the failure to wear life jackets is by far the number one cause of boating fatalities.

Modern life jackets are available in a wide variety of shapes, colors, sizes and technologies. Many are thin and flexible. Some are built right into fishing vests or hunter coats. Others are inflatable and as compact as a scarf or fanny pack until they hit water and automatically fill with air. Ensure all passengers on board understand where the life jackets are located and how to put them on and use them.

There’s no excuse for not wearing a life jacket on the water. Boat dealers or marine stores are the best sources for guidance when selecting this most important piece of safety equipment.



Starting in 2020, the U.S. Coast Guard working in cooperation with Transport Canada started transitioning to new life jacket labeling based on a performance classification system acceptable in both countries. If you have older approved life jackets, devices are approved in one country or the other, but not both. U.S.-approved devices are still acceptable in the U.S., and Canadian-approved devices are still acceptable in Canada when used in accordance with the approval label.

Always check and read the manufacturer's information booklet and label provided with all new life jackets. They will provide valuable information, including size, type, intended use, approval, inspection, and care information. For more information, go to <http://wearitlifejacket.com/>.

### Things to Know about Life Jackets:

- Life jackets are now classified as wearable or throwable on the label.
- We recommend that all boaters and passengers wear a life jacket at all times while boating.
- Certain life jackets are designed to keep the head above water and help you remain in a position that permits proper breathing.
- To meet USCG requirements, a boat must have an approved life jacket for each person aboard. Boats 16 feet (4.9 meters) and over must have at least one throwable device as well.
- All states have regulations regarding children wearing life jackets. Special life jackets for children are available and based on the weight of the child.
- Adult-sized life jackets will not work for children. To work correctly, a life jacket must be worn, fit snugly and not allow the child's chin or ears to slip through.
- Test life jackets for wear and buoyancy at least once each year. Discard waterlogged, faded, leaky or damaged jackets.
- Properly stow life jackets but make them easily accessible.
- A life jacket, especially a snug-fitting flotation coat or deck-suit style jacket, can help people survive in cold water.
- Various types of life jackets are also available for pets.
- A life jacket can save a boater's life, but only if the boater wears it. Set the example and wear it whenever near the water.

### Life Jackets Must Be:

- New jackets must be USCG or Transport Canada approved
- In good and serviceable condition
- Appropriately sized for the intended user
- Appropriate for the water activity
- Snug-fitting
- The best life jacket is the one you will wear





## Accessibility

- Throwable devices must be immediately available for use in emergency situations.
- Wearable life jackets must be readily accessible.
- Boaters must be able to locate and put them on in a reasonable amount of time in an emergency.
- They should not be stowed in plastic bags, in locked or closed compartments, or have other gear stowed on top of them.

## Child Life Jacket Federal Requirements

No person may operate a recreational boat underway with any child under 13 years old aboard unless each such child is either: (1) Wearing an appropriate PFD approved by the Coast Guard; or (2) Below decks or in an enclosed cabin.

Some states require that children wear life jackets at all times; check with the state boating safety authorities.

Since children grow quickly, many boat launches now feature free use of children's life jackets in several different weight categories.



KCB-0130

## Life Jacket Requirements for Certain Boating Activities Under State Laws

The USCG recommends, and many states require, wearing USCG-approved life jackets:

- For waterskiing and other towed/surf activities, use a life jacket designed for waterskiing. **It is illegal in many states to participate in towed water sports without a USCG-approved life jacket. Be aware that some specialized water sports vests are NOT USCG-approved and should be worn in addition to a USCG-approved life jacket.**
- While operating personal watercraft (PWC) use a life jacket marked for PWC or waterskiing use.

Check with the state boating safety authorities. Other rules may apply if boating in an area under the jurisdiction of the Army Corps of Engineers or a federal, state or local park authority. Special local rules are usually posted at the boat launch.

The new life jacket labels make it easier for the boat owner to choose the appropriate sizes and types of jackets for the boat. Labels may be in English, French Canadian or both languages depending on where they are marketed, but all will use icons for key performance indicators.



## Size

Chest size is used on ADULT devices to further define the fit not used on all others. Weight is used to define the basic size groups of:

- INFANT <30 LBS
- CHILD 30-50 LBS
- YOUTH 50-90 LBS
- ADULT >90 LBS

## Performance Level

The performance level indicates the amount of floatation provided. The higher the number, the more floatation at the increase in bulk.

- Lower numbers are more comfortable to wear and are a good choice for near-shore, calm water boating.
- Mid numbers offer more stability for people who do not swim and for novice swimmers and are a better choice for coastal boating.
- Higher numbers have the greatest floatation and are the best choice for remote areas where rescue times may be long, for non-swimmers, and for offshore use.

## Turnability

Typically, jackets with low performance levels will not turn an unconscious person face-up. Jackets with mid performance levels may not turn an unconscious person face-up. Jackets with high performance levels will turn an unconscious person face-up.

## Warnings

Some life jackets are not approved for waterskiing, tubing, wakeboarding, white-water paddling, or use on a personal watercraft.

## Find More Information

Additional information on the life jacket in the owner's manual and web sources.

## Manufacturer and Approval Information

Manufacturer's information for possible future recalls. USCG approval number and certification agency to assure the jacket meets the law and is safe to use.



## Use, Care and Storage Information

A summary of the use, care and storage information contained in the owner's manual.

<p><b>ADULT UNIVERSAL</b> User Weight: &gt; 41kg (&gt;90 lbs) Chest Size: 76-132 cm (30-52 in.)</p>	SIZE
<p><b>70</b>   — ↻ ↻</p>	PERFORMANCE LEVEL  TURNABILITY
<p> • Approved only when worn • Drowning hazard if not worn. • Must be fastened and properly adjusted to float the wearer.</p>	WARNINGS ON USE
<p>Choose and wear the device which fits you and your activity, visit <a href="http://www.XXXXX.com">www.XXXXX.com</a>* Read and keep the owner's manual and tags for info on wear and care.</p>	FIND MORE INFORMATION
<p>Company Name Company Address Company website if available Indication of Country of Origin USCG Approved 160.064/XXXXX ANSI/UL 1123- TYPE III Model: Lot No.</p> <p> Certifying Lab Identification and Address</p>	MANUFACTURER & APPROVAL INFORMATION
<p>Use: Fasten all closures and adjust for a snug fit. Inspect your life vest before each outing. Do not use if your life vest shows signs of weathering, damage, or rot. Care and Storage: Dry thoroughly after each outing. Store in a dry cool place out of direct sunlight.</p> <p></p>	USE, CARE AND STORAGE INFORMATION

KCB-0129



## Inflatable Life Jackets

U.S. Coast Guard-approved inflatable life jackets are authorized for use by persons 16 years of age and older (check the label).

- They require regular maintenance. Also, pay attention to the condition of the inflator.
- They must have a full cylinder and all status indicators on the inflator must be green. If all status indicators are not green, the device is not serviceable and does not satisfy the legal requirements for the wearable life jacket carriage requirement.
- They must be worn at all times.

## VISUAL DISTRESS SIGNALING (VDS) DEVICES

There are a variety of VDS devices for day, night, or day and night use. Pyrotechnic devices can be dangerous if used improperly; read the instructions before using. Pyrotechnic devices expire and must be replaced every few years, as stamped on the unit. Be sure to properly dispose of old pyrotechnics.

Distress lights and strobes are equipped with batteries that must be replaced every few years, as stamped on the unit.

Advancements in technology have led to a number of electronic VDS devices (eVDSD). These devices are battery-powered and contain one or more LED lights and possibly other features. While eVDSDs are not “USCG Approved,” they are accepted as “equivalent” if compliant with RTCM Standard 13200.0 for nighttime use. Several can be equipped with a VDS flag for day/night use and/or a whistle for audible signaling. Talk to your boat dealer about the best device for your use.

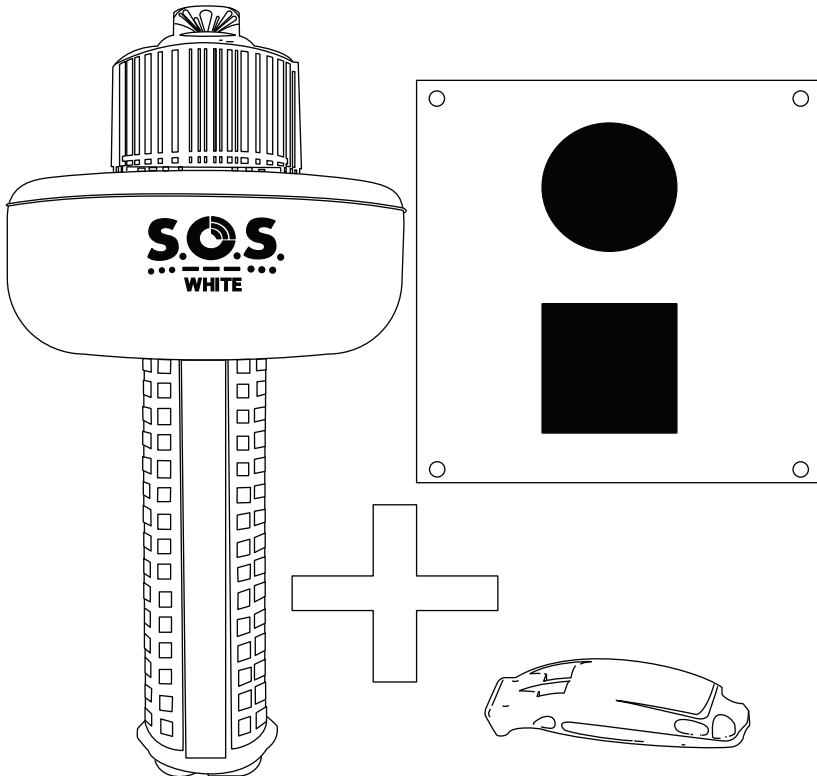

KCB-0131

Boats less than 16 feet (4.9 meters) must have USCG-approved visual distress signals (VDS) on board when operating between sunrise and sunset in coastal waters, including ocean bays, gulfs and sounds, as well as the Great Lakes, seas, bays and river mouths that are 2 or more miles wide and only to the point proceeding inland where the water narrows to less than 2 miles. Visit the U.S. Coast Guard website for additional information on specific VDS requirements for the boat.

Ensure all passengers on board understand how to operate all VDS. Keep VDS in a readily accessible area and within immediate reach at all times when boating.



## VISUAL DISTRESS SIGNALS

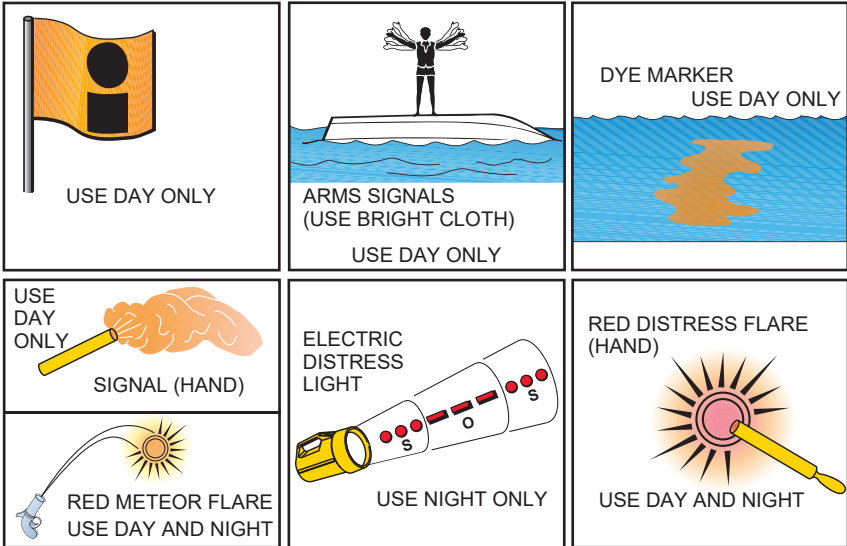

KC-0008C-B

Regulations prohibit using pyrotechnic VDS or any VDS in non-emergency situations.

VDS must be:

- USCG-approved
- In proper operating condition
- Safely stowed and readily available
- Within the clearly marked expiration date stamp on the device (where applicable)

Types of VDS vary by emergency situation. VDS are classified as either pyrotechnic or non-pyrotechnic.

**NOTE** — Some pyrotechnics may be restricted on certain bodies of water. Check with local authorities, or visit the National Association of State Boating Law Administrators (NASBLA) website: <http://www.nasbla.org> or the U.S. Coast Guard website: <http://www.uscg.mil> for additional information.

See the *U.S. Coast Guard Minimum Onboard Personal Safety Equipment Required* section of this manual for specific onboard requirements.



## AUDIBLE SIGNALING DEVICES

Audible (sound) signals are required to be on board all boats to alert other boats of your presence or intentions. A boat less than 39.4 feet (12 meters) must always have an efficient sound-producing device on board (Example: hand or mouth whistle, or a compressed or powered air horn).

A boat at least 39.4 feet (12 meters) but less than 65.6 feet (20 meters) operating in inland waterways must always have a power whistle or powered air horn and a bell on board.

All devices must be acceptable for use in marine environments, audible for 1/2 nautical mile and maintain a continuous four- to six-second sound duration. The diameter of the bell's mouth must be a minimum of 7.9 inches (20.0 centimeters).

Ensure all passengers understand how to operate all audible distress signaling devices on board. Keep these devices in a readily accessible area and within immediate reach at all times when boating.

See the *U.S. Coast Guard Minimum Onboard Personal Safety Equipment Required* section of this manual for specific onboard requirements and see the *Navigational Lights and Night Operation* section of this manual for usage information.

## NAVIGATIONAL LIGHTS

Navigational lights are intended to alert other boats to your presence and course and their use is essential to boating safety and the prevention of collisions. Knowledge of navigation lights is necessary for the boat operator. Regulations require that navigational lights be clearly lit and properly displayed at all times between sunset and sunrise, and always when operating in reduced visibility. The placement, shape and visibility requirements of navigational lights vary depending on boat size, type, activity and the body of water. Do not allow passengers, gear or stowed items to block navigation lights. Check with local authorities, or visit the NASBLA or U.S. Coast Guard website for additional information.

If the boat is equipped with bow and/or stern pole style plug-in lights, be sure to orient the pole properly in the receptacle and lock in place. The white light is for the stern and the combination red/green light is for the bow, center. If using separate bow lights, the red light is for the front left (port), and the green light is for the front right (starboard). After inserting, check for proper operation of the lights.

For additional information, see the *Navigational Lights and Night Operation* section of this manual.



## Show Lighting

The navigational lighting required by the USCG from sunset to sunrise and in inclement weather is extremely important to boat navigation. The lighting rules are not only designed to indicate direction and right-of-way, but are also designed to prevent night blindness and confusion with navigational aid, emergency and shore-based lights.

The arrival of inexpensive LED lights and red/green/blue (RGB) controllers suitable for “show” use has become extremely popular with boaters. Installing supplemental lighting for “show” can be very dangerous, confusing and distracting to other boaters, and may be illegal. The operator is responsible for complying with local laws and must be familiar with local marine lighting regulations that are constantly evolving before use. Keep these points in mind for show lighting:

- Do Not install lighting outside of the boat above the waterline.
- Do Not install lighting inside the boat above the gunnels where the light source can be seen directly from outside the boat.
- Use caution when changing RGB light color, as some light colors may not be compliant with certain local ordinances; blue lighting is typically reserved for law enforcement use only.
- Be sure to switch off show lighting and lighted accessories such as speakers (not navigation lights) when underway. Most states allow the use of underwater lighting while underway.
- Use only factory-installed, low-intensity courtesy lighting or “mood” lighting when underway.

### **NOTICE**

*Never use onboard accessory equipment containing LED lighting when underway.*





## RECOMMENDED SAFETY EQUIPMENT

Carry and know how to use the following equipment in addition to the required equipment on board at all times as an extra safety precaution:

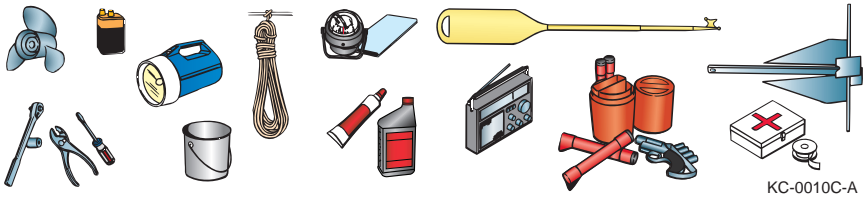

A non-electric horn or whistle	Local charts and compass
Anchor with at least 75 feet (23 meters) of line	Mooring lines and fenders
Bailing device (bucket, hand pump)	Portable AM/FM radio with weather band
Binoculars	Spare fuses
Cellular phone	Spare keys
Combination paddle/boat hook	Spare propeller and mounting hardware
Day/night distress signals	Sunglasses and sun block lotion
Extra engine oil	Waterproof flashlight and spare batteries
First aid kit and manual	

## PERSONAL LOCATION BEACON (PLB)

While an EPIRB is registered to the vessel, a PLB is registered to the user. Similar to an EPIRB, PLBs must be registered in the National Oceanic and Atmospheric Administration (NOAA) Search And Rescue Satellite Aided Tracking (SARSAT) database with personal information that is required to be updated every two years and reported if the unit is sold. Handheld waterproof marine PLBs also have long-lasting batteries stamped with an expiration date. Since the PLB identifies the user, it can also be used on land when hiking or for other remote activities.



## SITUATIONAL AWARENESS

A good captain knows that it is important to continuously observe the surroundings and traffic when operating. Good captains also use their eyes to track things around the boat and their ears to hear engine and mechanical issues. Technology should only be used to supplement the conditions and events happening around you and is not meant to replace situational awareness. While available technology and automation help captains see the big picture, the captain is responsible for knowing what is going on around the boat. If possible, post a lookout or lookouts when underway.

Do not get immersed in the boat's technology or blindly follow GPS routes without keeping watch or consulting depth charts. Study the manuals for each piece of equipment and monitor the information for the task at hand, be it depth, traffic, infrared camera, engine data, course or weather.

## DRIVING DEFENSIVELY

Sharing boats is becoming more popular in the boating culture. Boating has seen an influx of new, inexperienced and untrained boaters due to peer-to-peer boat-sharing apps and boat clubs. It is increasingly probable that someone on the water "tried" boating because it looked fun. Many of the boat owners sharing their boats do little more than cover safety equipment, starting, stopping and docking instructions. With shares lasting half a day or less, there is little time for much training, let alone covering the rules of the road and navigation.

Boat-sharing is in a legal gray area and is not clearly defined in maritime law. Enforcement of existing rules is nearly impossible and almost always after-the-fact. Operators should assume that the other boat operator is untrained and should drive defensively. Boaters choosing to share their boat should discuss the issue with their insurance agent first and consider a mandatory captain requirement. Use only reputable sharing services and frequently check for new or updated USCG and state requirements.

## SMALL BOATS AND SWIMMERS

Canoes, kayaks, paddleboards and swimming inflatables have become impulse purchases for many, as they appear fun to use and prices have fallen. Most of these operators are new to the sport and have no training on rules of the road or navigation. This is further complicated by the low, thin profile that makes these small boats difficult to see, especially in the sun, glare and rough water. Operators should keep a close lookout for these boats, swimmers and other boats. Assume that the person is untrained and give them plenty of space.



## KNOWING THE BOAT

Be thoroughly familiar with onboard systems and other equipment, especially the critical systems and equipment such as throttle and shift controls, steering, backup steering, running lights, fuel filters, sea strainers, and all emergency safety equipment. Should an emergency arise, the captain will need to act safely and efficiently.

## SPECIAL NEEDS PASSENGERS

Keep these special precautions in mind when enjoying a day on the water with passengers who have special needs.

### Toddlers

- Never leave children in the boat without adult supervision.
- Must weigh at least 18 pounds (8.2 kilograms), since that is the smallest children's life jacket approved by the USCG. Life jacket must be worn whenever near the water.
- Any device the child is placed in must have flotation.
- Child-proof the boat just like a home. Be sure all gates and compartments are closed and latched.
- Keep a close watch on the child's reaction to speed and conditions and react accordingly.
- Use a higher than normal SPF waterproof sunscreen and re-apply more often than usual.
- Find a safe area to put the child down without risk of going overboard. Allow the child to get accustomed to the surroundings before launching/leaving.
- Keep trips short, but let them have some fun if possible.

### Pregnant Women

- Go boating during the day and in calm seas.
- Avoid sharp turns and slow down for large wakes.
- Drink more water than usual to stay hydrated.
- It is a good idea to stay seated in the accommodation deck area while underway.
- Stay close to the home port in the third trimester.



## People with Handicaps and Elderly People

Depending on the disability, there are many marine-specialized options available to make boats safer and friendlier. Researching on the internet for your specific needs is the best way to start.

## Pets

- Not all pets can swim; consider a life jacket.
- If playing fetch in the water, get a pet-friendly boarding ramp to make re-boarding easier.
- Provide a shaded area and plenty of fresh drinking water.
- Consider foot protection for hot sand and boat surfaces.
- Allow the pet to get accustomed to the surroundings before launching/leaving. Keep the first outing short to allow the pet to get used to the boating environment.

## CRUISING LIMITATIONS

- Scan constantly for people, objects and other watercraft. Be alert for conditions that limit your visibility or block your vision of others.
- Operate defensively at safe speeds and keep a safe distance from people, objects and other watercraft.
- Do not follow directly behind other watercraft.
- Do not go near others to spray or splash them with water.
- Avoid sharp turns or other maneuvers that make it hard for others to avoid you or understand where you are going.
- Avoid areas with submerged objects or shallow water.
- Operate within your limits and avoid aggressive maneuvers to reduce the risk of loss of control, ejection and collision.
- This is a sophisticated boat—not a toy. Sharp turns or jumping waves or wakes can increase the risk of back/spinal injury (paralysis), facial injuries, broken legs, ankles and other bones. Do not jump waves or wakes.
- Do not operate the boat in rough water, bad weather or when visibility is poor; this may lead to an accident causing injury or death. Be alert to the possibility of bad weather. Take note of weather forecasts and the prevailing weather conditions before setting out in the boat.
- Leave a “float plan” with a responsible person on shore. Tell where you plan to go and when you plan to arrive, and provide a description of your boat. Advise this person if your plans change and also when you arrive to prevent false alarms. Refer to *Float Plan* in this manual for additional information.



## HAZARD INFORMATION

- Never start the engine or let it run for any length of time in an enclosed area. Exhaust fumes contain carbon monoxide, a colorless, odorless gas that may cause death within a short time. Always operate the boat in an open area.
- Do not use the reverse function to slow down or stop the boat, as it could cause you to lose control, be ejected or impact the steering wheel or other parts of the boat. This could increase the risk of serious injury. It could also damage the shift mechanism.
- Reverse can be used to slow down or stop during slow speed maneuvering, such as when docking. Once the engine is idling, shift to REVERSE and gradually increase engine speed. Make sure that there are no obstacles or people behind you before shifting into REVERSE.
- Stop the engine and remove the clip from the engine stop switch before removing any debris or weeds that may have collected around the propeller.



## WATER SPORTS

### DEVELOP WATER SENSE

What is water sense? Water sense is developed by familiarizing yourself with the boat, driving, water, equipment and maintaining vigilance.

Familiarize yourself and follow The Watersport Responsibility Code.



KCB-0098



#### **WARNING** Control Hazard:

***It is unlawful to participate in water sports while under the influence of alcohol or other drugs.***

Some boats are not designed or recommended to be used for water sports. For recreational boats, water sports include any activity performed in the water such as waterskiing, kneeboarding, wakeboarding, wakesurfing, hydrofoiling, swimming, diving, snorkeling or gliding using a device that may be pulled by a boat. Boats equipped with a ski pylon, tower or hard top tow point, or a transom-mounted ski tow eye can be used for most water sports in accordance with the capacity limits listed on the label.

Inflatables, also known as tubes, have some unique safety considerations and require the use of both stern eye strong points in combination with a proper tube harness and tow rope; see *Inflatables/Tube Tips* in this section for more information. Parasails and kites require specialized equipment and training and should never be used with a recreational boat.

Check with local and state authorities or water sports clubs and affiliations for additional information.



## PLATFORM DRAGGING

These dangerous and even fatal activities can lead to any or all of the following, as well as other dangers not listed here:

- Carbon monoxide poisoning
- Severe injury from a rotating propeller
- Drowning or entrapment under the water

### NOTICE

*It is UNLAWFUL to be on or holding on to the boarding platform, swim deck, swim step, swim ladder or any portion of the exterior of the transom at any time while the boat is running or underway in any direction and at any speed.*



### WARNING

***Personal Injury Hazard: Body, teak or platform dragging is extremely dangerous and can be fatal. Never hold on to the transom of a boat while in the water when the boat is running or underway.***

- ***Do not use the boarding platform or ladder for any purpose other than boarding the boat or entering the water.***
- ***Do not use the boarding platform or ladder while the engine is running.***
- ***Do not swim under the boarding platform when the engine is running.***



SECTION

2

SAFETY

## WATER SPORTS GUIDELINES

# WAKE RESPONSIBLY

**1** Stay at least 200 feet away from the shoreline, docks, or other structures.

**2** Keep music at reasonable levels. Sound travels well over water. If it's loud enough to hear at 80 feet back, it is likely loud enough for homeowners to hear, too.

**3** Minimize repetitive passes on any one portion of shoreline. Once you've run the same line for a while, move on to another area.

YOU ARE RESPONSIBLE FOR YOUR OWN WAKE.



**wsia**  
WATER SPORTS INDUSTRY ASSOCIATION  
wsia.net





## Boat Operator, Occupants and Participants

The following water sports guidelines only cover the general conditions that frequently arise. The participants must respond to the constantly changing weather and the conditions of the sea by using reasonable and safe judgment in light of the circumstances.

- Always ensure that all water sports participants and occupants of the boat, especially the operator, are fully aware at all times of the participants' condition and location in the water, as well as the surrounding environment.
- Make safety the primary concern of all involved during the activity. Only allow safe and capable participants to engage in the activity.
- The boat operator and water sports participants must always know their limitations in the activity and never exceed them.
- Never perform water sports in or near:
  - Congested areas
  - Restricted areas
  - Navigation or other waterway markers
  - Other boats
  - Other water sports participants
  - Obstructions in the water
  - Shorelines
  - Shallow water
  - Hazardous weather conditions
  - Hazardous waterways, rapid moving water, dams, spillways, etc.
  - Areas or times of restricted visibility
  - Hours between sunset and sunrise
  - Locations too far from shore that could hinder immediate rescue or emergency help if needed
- Always engage in water sports activities in safe waterways only.
- Always attach the water sports tow rope to approved attachment points on the boat.
- Never jump from a boat that is moving at any speed, and do not enter or exit the water when the engine is running.
- Never use different length ropes simultaneously for water sports activities.
- Always make sure that participants know and use approved skiing hand signals and common skiing courtesy.
- Before starting, always agree to speed and communication hand signals between the boat operator, spotter/observer and participants.



- Before starting, always inspect the water sports equipment and tow eye, tow point and tow line for safe operating condition, or damage that may lead to failure.

## Know Water Sports Hand Signals

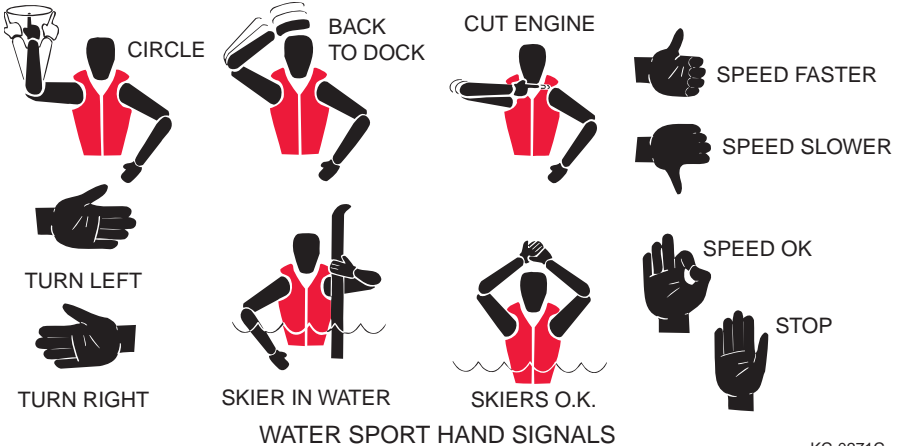

KC-0271C

## Boat Operator Specific Guidelines

The following guidelines are for the boat operator while a participant is in the water.

- Always have a “spotter” (designated observer) other than the boat operator on board to ensure the safety of the participants in the water and provide communication to and from the boat operator and the participants.
- Always turn the engine off from a safe distance when approaching participants in the water and allow them to reach the boat. Never run the engine near a person in the water.
- Never operate the boat in reverse to retrieve anyone in the water.
- Always return immediately to a fallen water sports participant. Always approach the participant on the operator’s side while keeping the participant in view from a direction opposite the wind or seas.
- Never drive directly at a person in the water or directly behind another boat.
- Always maintain a safe distance from people and objects in and on the water.



- Always look in the direction you plan to turn before turning the boat to pick up a fallen skier.
- Never retrieve any object from the water while the engine is running.
- Always keep the skier in view when the skier is entering or exiting the boat.
- Always watch the skier as the line begins to tighten (in case the rope wraps around ski or skier).
- Always look ahead before starting.
- Always start from a safe place with good forward and peripheral visibility.
- Always check direction of steering before starting, ensuring that the boat steers straight.
- Always be aware of what is occurring in front of the boat, and of a participant's condition.
- Always display a "skier down" flag whenever a skier is in the water and not skiing.
- Always follow the approved towing pattern for the waterway in which you are operating.

### **Additional Guidelines for Participants in the Water**

The following guidelines are for the water sports participant.

- Never participate in water sports if you cannot swim.
- Always wear a bright-colored USCG-approved activity life jacket at all times. Wear suitable protective clothing or gear and/or a wet suit to prevent impact injuries, abrasions and hypothermia.
- Never approach or enter the boat if the engine is running.
- Always avoid the boat's propeller. Even when the propeller is not rotating, its sharp edges can cause serious injury.
- Never put any part of your body through the handle of the ski line or wrap the line around any part of your body.
- Never enter the water from a boat that is running or moving at any speed.
- Always indicate that you are clear of the boat prior to the operator starting the boat or putting the boat into gear and tightening the rope.



### ***Inflatables / Tube Tips***

Today's market offers various types, shapes and sizes of towed inflatables (known as "tubes" or "inflatables"). A person can ride "in" or "on" (depending on the style) these inflatables while out on the water. Regardless of the type, they all produce tremendous stress on the tow point and rope, far greater than devices like water skis, kneeboards or wakeboards. When using tubes, keep the following points in mind:

- Follow the general water sports safety guidelines in this section for operating the engine, using life jackets, using a spotter, guarding against rope entanglement, reviewing equipment condition before use, understanding rider skill levels, and abiding by regulations for distances to other boats, docks and shorelines.
- Do Not exceed a towing speed greater than 8 mph (11km/h) for small children, 15 mph (24 km/h) for children up to 18 years old, or 20 mph (32 km/h) for adults.
- Do Not attempt to intentionally cause a tube rider to fall and use extreme caution with multiple riders to prevent slamming riders together.
- Do Not use tow ropes shorter than 50 ft (15 m), or longer than 65 ft (20 m). Be sure the tow rope and tube is rated for the combined weight of all riders and uses the proper attachment points. A braided tow rope offers a degree of stretch to minimize shock to the rider.
- Do Not use ski tow pylons, hard top, tower or ski tow eye points for tubes. Use both port and starboard stern eye strong points with a tube tow harness to attach the tube tow rope. Add a floating ball to the tow rope to keep the rope on top of the water and improve performance. If you do a lot of tubing, invest in a transom-mounted bracket made specifically for towing tubes (see your dealer).
- Check the tube air pressure often and keep at the manufacturer's recommended level as listed on the device. Pressure levels can change rapidly from sun and shade; too low and it creates additional drag, too high and it may cause tube failure.
- Tow only one tube at a time.
- Read and understand the user's manual for the tube; instruct children on the Do's and Don'ts.



### **CAUTION**

***Personal Injury/Equipment Damage Hazard: Ski tow pylons/tower/hard top/ski eye tow points are not designed for use with tubes. The added stress of the tube may cause a dangerous recoil or damage the tow point. Damage to the pylons/tower/hard top/ski eye tow points is not covered by the boat or equipment manufacturer's warranty. If towing tubes/inflatables, use both stern eye strong points with a tube tow harness to attach the tube tow rope. Consult the boat manufacturer for stern eye tow limits.***

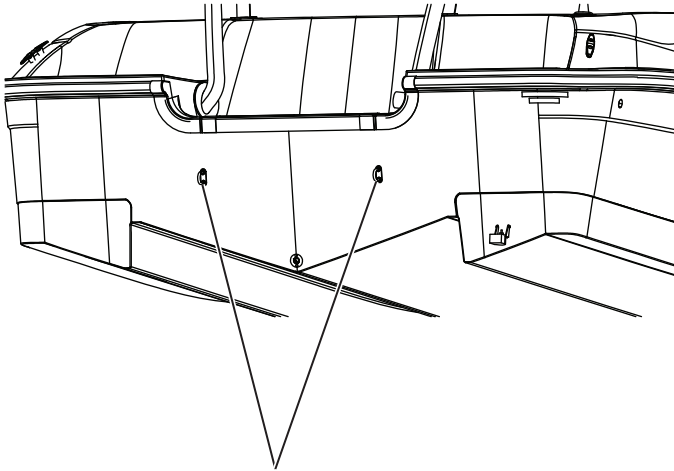

**STERN EYES**

KCB-0108

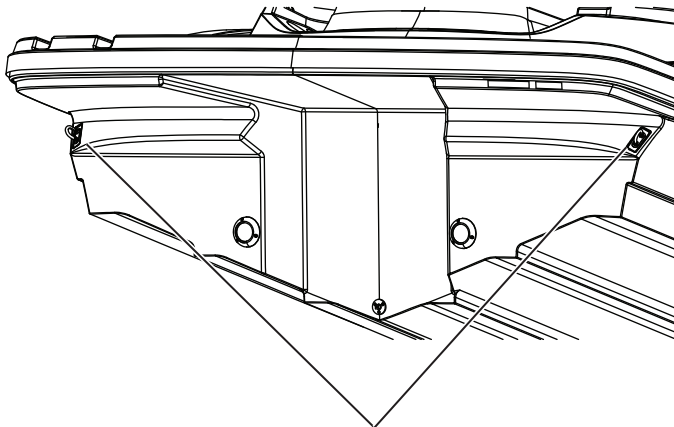

**STERN EYES**

KCB-0109



### **Using the Platform/Boarding Ladder**

 **WARNING** *Personal Injury Hazard: Always turn the engine off whenever anyone is in the water near the boat.*

To board, carefully deploy and use the boarding ladder if available. You may also pull yourself onto the boarding platform to enter the cockpit of the boat. Boats equipped with a boarding platform have a few extra precautions to be aware of:

- NEVER allow anyone on the boarding platform or in the water near the platform while the engine is running.
- NEVER attempt to surf on or off the platform while the engine is running.
- NEVER “platform drag” or touch the boarding platform from the water while the engine is running.
- NEVER exceed the weight capacity of the boarding platform. All boarding platforms have weight limits. If there is no capacity label, ask the dealer.
- Boarding platforms may be wet and slippery. Advise passengers to use caution and any available handholds when using the platform. Never apply wax to the working deck portion of the platform.
- If the boarding platform is equipped with a ladder, be sure the ladder is fully retracted and secured before operating the boat.
- If the boarding platform is removable, be sure it is properly secured before operating the boat.

### **Designated Occupant Seating**

It is important to use the designated occupant positions (DOP) when underway, if applicable. You must also understand that even though the capacity label identifies the number of passengers for your model, the actual number of passengers is determined by weight. Your boat model may have 10 DOP seats and a capacity label that says 8 persons or 1500 pounds. This means that you may have a maximum of 10 people as long as the sum total weight of all the people and gear does not exceed 1500 pounds. Likewise, it may be possible that the 1500-pound limit *could be exceeded with only 7 people or less.*

For more information on capacity, see *Section 1, Hull Identification, Capacity and Safety Plates*. For more information on seating, see *Section 2, Safety*. For more information on the proper distribution of passengers on the boat, see *Section 7, Boat Loading*.



## Water Sports Safety

### IMPORTANT

***The following water sports safety warnings and practices represent some (but not all) common risks encountered by users. Always use common sense and good judgment.***

**Before skiers/riders get in the water:** Waterskiing or riding instruction is recommended in advance. Instruction will teach general safety guidelines and proper waterskiing or riding techniques, which may reduce their risk of injury. For more information on waterskiing or riding schools, contact the dealer, association or local waterskiing club.

Inspect all equipment prior to each use. Check bindings, fins, tube, attachment, tow rope and flotation device. Do not use if damaged.

**Special boat considerations:** A knowledgeable and responsible driver along with a separate observer is the most important safety device on any boat.

- Some states have specific regulations for allowable propulsion systems that can be used for tow sports, especially wake surfing. It is the operator's responsibility to know the applicable regulations.
- Never exceed the passenger or weight limitations of the boat.
- Never allow passengers to hang outside the boat or towed device or sit on the gunwales or anywhere outside of the normal seating area.
- Never allow water to overflow the bow or gunwales of the boat.
- Uneven weight distribution or additional weight may affect the handling of the boat.

**Tow ropes:** Tow ropes come in different lengths and strengths for different activities. Make sure any rope used is suited for that activity and that it is in good condition.

- Never use a rope that is frayed, knotted, unraveling or discolored from use or being left in the sun. If a rope breaks while in use, it can recoil at the skier/riders being towed or into the boat where it might strike passengers. Replace tow ropes with any sign of damage.
- Never use a tow rope with elastic or bungee material to pull skiers or riders.
- Rope should be attached to the boat in an approved fashion with hardware designed for towing. Refer to the boat manual for instructions on proper tow rope attachment.
- Always keep people and tow ropes away from the propeller, even when idling.



- If a tow rope should become entangled in a propeller, shut off the engine, remove the key and secure it in a safe location before retrieving the rope.
- Tow ropes should be neatly stowed in the boat when not in use.

**Preparing to ski or ride:** Always have a person other than the driver act as an observer to look out for the skier/ rider.

- Be sure the driver is aware of the experience and ability level of the skier/ rider.
- The driver, observer and skier/ rider need to agree on hand signals before skiing or riding. Signals should include READY, STOP, SPEED UP and SLOW DOWN.
- Start the engine only after making sure that no one in the water is near the propeller.
- Turn off the engine when people are getting into or out of the boat, or in the water near the boat.
- Always make sure the tow rope is not wrapped around anyone's hands, arms, legs or other parts of the body.
- Start the boat and move slowly to remove slack until the tow rope is tight.
- When the skier/ rider signals READY "hit it" and there is no traffic ahead, take off in a straight line. Adjust the speed according to the signals given by the skier/ rider.

**Skiing or riding:** The boat and skier/ rider should always maintain a sufficient distance from obstacles so a skier/ rider falling or coasting and/ or boat will not encounter any obstacle.

- Do not use in shallow water or near shore, docks, pilings, swimmers, other boat or any other obstacles.
- Use only on water.
- Never attempt land or dock starts or stops. This will increase the risk of injury or death.
- The faster the skier/ rider skis or rides, the greater their risk of injury. The skier/ rider should be towed at an appropriate speed for his or her ability level.
- Never make sharp turns that may cause a slingshot effect on the skier/ rider's speed.





**Fallen skier or rider:** Falling during water sports is commonplace and injuries can occur from a variety of causes.

- If the skier/rider does not immediately indicate that they are “OK,” assume that they need assistance.
- Circle a fallen skier/rider slowly to return the tow rope handle or, pick up the fallen skier/rider.
- Turn off the engine when near a fallen skier/rider.
- Always keep the fallen skier/rider in view and on the driver’s side of the boat.
- Display a red or orange “skier down” flag to alert other boats that a skier/rider is down if required by the state in which you are operating.

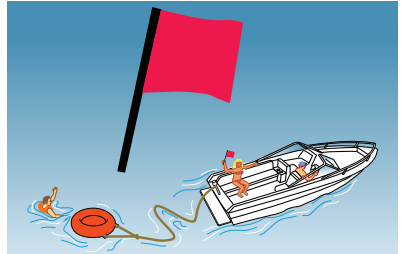

KC-6017

## Water Sports and Towing Safety

Boat operators, skiers and boarders must all be aware of current boating and water sports rules and pay attention to safe operating procedures and skiing practices at all times. If skiing or boarding is a new sport to you, seek certified training before starting. Thoroughly read all information provided by the water sports equipment manufacturer.

Always remember that the majority of water sports injuries are the result of impacts with other objects. Know the area you are boating in.

Always maintain a clear vision of where you are going and be aware of what is going on around you. Constant vigilance will go a long way toward preventing accidents. Skiers, boarders and other water sports participants must always wear a USCG-approved life jacket. It’s the law!

Contact with rotating propellers is one of the most dangerous hazards that occurs from negligence of operators, passengers and bystanders. A propeller is designed to travel in the water and rotates at a speed that can cause death if it comes into contact with a human. Severing, deep lacerations, blood loss, trauma and exposure to microorganisms in the water that enter the bloodstream can result in death or serious injury.

**STOP PROPELLER STRIKES by always using caution and:**

- OBSERVING all warnings and keeping all safety equipment in use and in place.
- STOPPING the engine when swimmers are near the boat and in the water.
- MAKING SURE all passengers are seated on a horizontal seat cushion whenever the boat is in gear or moving.
- NOT ALLOWING passengers to enter the water when the engine is running.
- USING the boat's emergency stop switch at all times.
- MAKING SURE all operators are properly trained and qualified to operate the boat.
- KEEPING your eyes on your path as well as the water sports participant.
- NOT ALLOWING water sports participants to be in the path of other boaters.
- STAYING CLEAR of swimmers and other water sports participants by maintaining visual surveillance.
- KNOWING the correct water sports hand signals.
- NOT ALLOWING children under 11 years of age to occupy the open bow area unless accompanied by an adult.
- USING an observer during water sports activities.

**Water Sports Responsibility Code**

**BE AWARE** there are risks in boating and water sports that good judgment and personal awareness can help reduce. To increase enjoyment of water sports, follow the 10 points of the code.

**In water sports, it is the boater's responsibility to:**

- ALWAYS become familiar with applicable laws, waterways and inherent risks.
- ALWAYS have a capable observer in addition to the driver, and use agreed-on hand signals.
- ALWAYS wear a properly fitted life jacket approved by your country's agency.
- ALWAYS read the user's manual and inspect equipment before use.
- ALWAYS ski and ride under control, at proper speeds and within your limits.
- ALWAYS turn the ignition off when anyone is near the boat power drive unit.



- ALWAYS stay clear of engine exhaust to avoid carbon monoxide poisoning.
- NEVER “platform drag” or touch boarding platform while the engine is running.
- NEVER ski or ride near swimmers, shallow water, other boats or obstacles.
- NEVER operate boat and never ski or ride under the influence of alcohol.

### Driver: Best Practices

- The boat driver plays a critical role in the enjoyment and safety of all towed water sports participants. Do not allow inexperienced drivers to drive for skiers/riders without thorough instruction and training. We encourage all boat operators to take a boater’s education course. See the state’s boating authority for available courses or other operating requirements.
- Keep music at reasonable levels. Sound travels well over water.
- Wait for a clear boat path ahead before accelerating.
- Make sure to use the proper rope for the sport. A rope designed to pull a skier is not the recommended rope for towing a tube.
- If skiing, boarding or tubing with more than one person, make sure all tow ropes are the same length.
- Keep a 200-foot buffer zone on all sides of the boat and stay in water that is safe for the skier/rider and draft of the boat.
- Make sure the tow line unwinds smoothly without getting snagged on anyone or anything.
- Idle forward to make the rope tight.
- Accelerate only when the tow rope is completely tight and the skier/rider has given the “hit it” signal. The words GO and NO can be easily confused with nearby wind, water and engine noise. It is best to find another signal other than GO to tell the driver to power up. “Hit it” or “boat driver” are better options.
- Always approach fallen skiers/riders in the water from the driver’s side so the driver does not lose sight of them.
- Minimize repetitive passes on any one portion of shoreline. Once you’ve run the same line for a while, move on to another area.

**TURN OFF ENGINE** when a skier/rider is near the boat, rather than running the engine in NEUTRAL. An accidental bump of the throttle when the engine is running could put the boat in gear.

- DO NOT let the tow rope slip under the boat and become tangled in the propeller. It is a good practice to keep a knife on board should this situation occur.



- Always pay attention to the water ahead, the surrounding traffic and the onboard observer. The observer must always keep the boater aware of the skier/rider status.
- DO NOT whip skiers or riders near shores, docks, other boats or fixed obstructions; they can glide 100 feet or more after they let go of the rope.

**⚠ WARNING** *Entanglement Hazard: Never accelerate before the rope is 100% tight and before the skier/rider gives the “hit it” signal. Accelerating before the “hit it” signal is given could result in the skier/rider becoming entangled in the rope.*

### Driving Pattern

Check with local lake laws before driving any pattern. Some areas require operators to drive skiers/riders in preset patterns.

Operators who want to minimize the rough water for the skier/rider should use a dog-bone pattern when driving. A dog-bone pattern follows the same path from one end of the course to the other, with tight controlled turns at each end. Use this pattern where few other boats are operating.

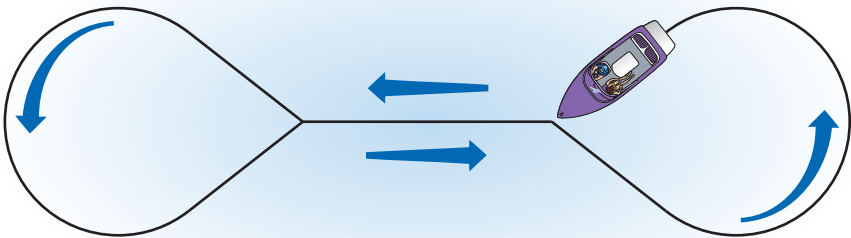

KC-0317C-A



In areas where many boats are operating, use a large racetrack pattern.

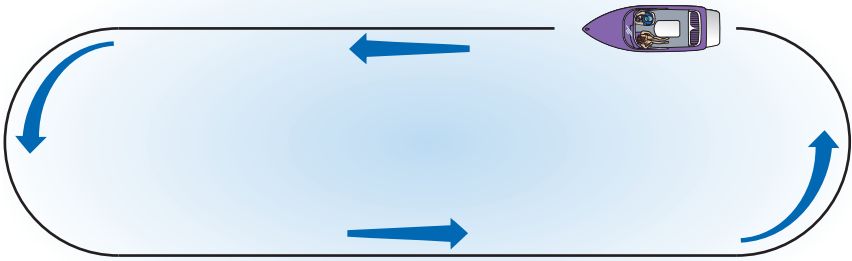

KC-0358

### Falling Tips for Every Sport

- Sudden falls happen. DO NOT put any body parts (arms, legs, head) inside the rope handle.
- Tighten the life jacket straps for a snug fit.
- Let the handle go as soon as you sense you're about to fall. Falling is better than dragging.
- Roll with it. Bow your head, bend your knees, tuck in your arms and make like a beach ball.
- Signal the observer to let them know you are OK after a fall.
- After you fall, lift the ski or board above the water so other boaters can see you.
- When learning advanced maneuvers, it's best to seek training from a professional.
- A little advice will cut down on falls, shorten the learning time and reduce the chances of an injury.



## Water Sports Tips

These tips are designed to help speed learning while ensuring safety. Practice, training from a professional and advice from experienced boaters are the best tools for learning safety when it comes to water sports.

For additional information visit: [www.teamusa.org/USA-Water-Ski](http://www.teamusa.org/USA-Water-Ski)

**REMEMBER:** It is important to follow the manufacturer's recommendations for the intended use of the water sports equipment.

**REMEMBER:** It is illegal in many states to participate in towed water sports without a USCG-approved life jacket. Be aware that some specialized water sports vests are NOT USCG-approved and should be worn in addition to a USCG-approved life jacket.

**BE AWARE:** The boater is responsible for their own wakes. Be considerate of other boaters, especially small fishing boats, canoes, kayaks, paddleboards and other low-profile boats that can overturn easily. Also, be aware of your wakes in relation to swimmers, docks and boats tied to docks.

## Section 3

# BOATING REGULATIONS AND YOUR RESPONSIBILITIES

The U.S. Coast Guard (USCG) is the federal authority on U.S. coastal and inland waterways, but state and local regulations may exist that exceed USCG regulations. The purpose of all these regulations is to assist the boating public and maintain navigational order on waterways.

Many state equipment requirements go beyond USCG requirements. Contact state and local boating authorities for further information. Equipment requirements for coastal and inland waters differ. Check with local authorities or the USCG for further information about coastal water requirements.

Boating regulations are enforced by USCG, state and local authorities. Operators/owners are subject to marine navigation regulations for both federal and state waterways. Operators/owners must comply if enforcement officers signal them to stop the boat or if they ask to board the boat.

Many USCG, state and local resources are available. For additional and current information on regulations, safety and navigation, contact the local USCG unit or local marine authority.

See the *References and Contact Information* section of this manual for a list of resources.

## BOAT OWNER / OPERATOR RESPONSIBILITIES

As a boat owner/operator, understand and be aware of USCG federal regulations as well as state and local regulations where operating the boat. Boating regulations include, but are not limited to, boat regulations, boat equipment regulations and navigational regulations.

Operators/owners must have on board at all times all mandatory safety and boat equipment as regulated by the governing authorities. All equipment must be maintained in proper working order.

## SAFETY

Boat owners/operators are legally responsible for their safety, the safety of their passengers and the safety of other boaters. In addition, they are responsible for the operation and navigation of the boat under all operating conditions. The boat must be in compliance with USCG safety equipment regulations.



## REGISTRATION

The USCG requires that all power boats operated on the navigable waters of the United States be currently registered in the state in which they are principally used. Many states require current registration in that state whenever boating on waters within their state boundary. Always contact state boating authorities (and authorities in neighboring states) for registration information on boats and trailers.

Registration numbers must be current and clearly displayed on the boat according to the defined regulations. Registration certificates must be current and on board at all times.

State and local authorities may require additional registration for boating on certain waterways. Check with state and local authorities for additional registration information.

For more information visit:

- U.S. Coast Guard Office of Boating Safety:  
<http://www.uscgboating.org>
- National Association of State Boating Law Administrators:  
<http://www.nasbla.org>

## INSURANCE

Boat owners are legally responsible for any damage or injury caused when they operate the boat when an accident or collision occurs. They are also legally responsible even when someone else operates the boat and causes damage or injury. Individual states have laws detailing minimum insurance needs. Contact the insurance agent to verify the type of insurance needed BEFORE operating the new boat.

## REPORTING ACCIDENTS

The USCG requires the owner/operator of a boat involved in an accident to report the incident to the proper marine law enforcement agency for the state in which the accident occurred. If a person dies or disappears as a result of a recreational boating accident, the boat owner/operator must immediately notify the nearest state boating authority. If a person dies or has injuries requiring more than first aid, the owner/operator must file a formal report within 48 hours of the accident. An owner/operator has 10 days to file a formal report for accidents exceeding \$500 in property damage or complete loss of the boat. Go to <http://uscgboating.org/recreational-boaters/>, Accident Reporting, for information and form download.





## BOATING UNDER THE INFLUENCE



KCB-0011

Federal and state laws prohibit the operation of a boat while under the influence of alcohol or drugs, and authorities actively enforce these regulations. If the operator's blood alcohol content is at or above the legal limit, violators are subject to civil and criminal penalties and imprisonment. Operating a boat under the influence can also result in a loss of motor vehicle driving privileges.

Alcohol and drugs slow reaction time and affect judgment. This type of impaired operation may result in death or severe personal injury.

Owners/operators are responsible for their passengers, including alcohol and drug use and onboard behavior.

Regulations and penalties for operators and passengers may vary from state to state. Contact local and state boating authorities for specific information.

## OPERATOR'S LICENSE AND EDUCATION

This manual does not provide complete training on all aspects of boating safety, operation or regulations. Boating authorities highly recommend that all boat operators and passengers seek additional training in boating safety and seamanship from a USCG-approved course.

Licensing requirements can vary widely from state to state. Most states require operators under the age of 18 to be licensed; however, some states require all operators to be licensed and have the license on the boat during operation. Some states require boat operators to complete a boating education/safety course to obtain a safety certificate before licensure. Pay special attention if you will be operating on boundary waters shared by two or more states, as the requirements may change once you cross the boundary.

Check with state and local authorities for requirements of an operator's license, certificate or training before you or anyone operates the boat.

See the *References and Contact Information* section of this manual for a list of some of the agencies and organizations that offer water/boating safety courses, first aid/CPR, or other recommended training and/or information.

## OPERATION BY MINORS

Minors must always be supervised by an adult whenever operating a boat. Many states have laws regarding the minimum age and licensing requirements of minors. Regulations may vary from state to state. Contact local and state boating authorities for specific information.



## EMERGENCY ASSISTANCE

An operator seeing a distress signal or suspecting a boat is in trouble must assume it is a real emergency and render assistance immediately as long as it can be done safely.

In accordance with Federal law, in U.S. waters, the operator must render assistance to any individual found at sea in danger of being lost, so far as the operator can do so without serious danger to the operator's vessel or individuals on board. An operator who fails to render such assistance can be fined not more than \$1,000, imprisoned for not more than 2 years, or both. The 1971 Boating Safety Act grants protection to a "Good Samaritan" boater providing good faith assistance, and absolves the boater from any civil liability arising from such assistance.

Under general maritime law in international waters on the other hand, if the operator undertakes to perform acts to rescue or aid those in distress, the operator is subject to liability for reckless or wanton conduct or, for failure to exercise reasonable care (negligence) if he worsens the position of the victim.

### **NOTICE**

*The operator in charge of the boat is obligated to provide assistance to any individual in danger if such assistance can be provided safely. Carefully assess the situation at hand and assist if possible. If the operator does not possess the skills to safely assist another boat in trouble with the highest degree of care, call for help and stay in the area until help arrives.*

## NEGLIGENT OPERATION

Federal law prohibits the negligent or grossly negligent operation of a boat and/or interference with the safe operation of a boat so as to endanger lives and/or property. Some actions that may constitute grossly negligent operation (criminal offense) are:

- Operating a boat in a designated swimming area
- Excessive speed in the vicinity of other boats or in regulated waters
- Hazardous waterskiing or other water sports practices
- Bow riding, or riding on a seat back, gunwale, boarding platform or transom
- Operating a boat while under the influence of alcohol or drugs (severe penalties may be imposed for boating under the influence [BUI])



Other actions that constitute negligent operation, such as, but not limited to:

- Failure to use handhold
- Overloading or improper loading
- Using a boat in weather or sea conditions beyond the intended design of the boat or beyond the skill or experience of the operator
- Continued operation with operator's visibility blocked or impaired
- Modification to boat causing an unsafe operating condition

## RESTRICTED AREAS

### Security Zones

Operators must avoid all waterways and areas that are restricted, such as military installations, power plants and petroleum and chemical facilities. Because of the threat of terrorism, the U.S. Coast Guard has implemented and will continue to enforce strict limits on boats near U.S. Navy and U.S. Coast Guard ships and other potential targets.

### Naval Vessel Protection Zones

Do not approach within 100 yards of any U.S. Naval vessel. Slow to minimum speed within 500 yards of any U.S. Naval vessel. Operators needing to approach within 100 yards to ensure a safe passage in accordance with the Navigation Rules must contact the U.S. Naval vessel or the U.S. Coast Guard escort vessel on the boat's VHF radio (channel 16) for authorization.

### Commercial Shipping Safety Zones

Do not operate the boat near cruise liners or certain waterfront commercial installations such as ferry terminals. Observe and avoid all security zones and commercial port operations.

### Bridges and Shipping Channels

Do not stop or anchor beneath bridges or in shipping channels. Operators doing so should expect to be asked to move and/or be boarded by law enforcement officials. Anchoring in these areas is dangerous for the operator and others on the water.



## AMERICA'S WATERWAY WATCH

Boat operators can help the U.S. Coast Guard in keeping waterways and coastal installations safe and secure. Boat operators can do this by participating in America's Waterway Watch (AWW). Boaters reporting suspicious activities to AWW should call 877-24WATCH if noticing suspicious activity or behavior on or near the water.

In cases of immediate danger to life or property, call the U.S. Coast Guard on channel 16 VHF-FM or dial 911 for emergencies.

## FISHING

Fishing can be very exciting and distracting for the operator when the action gets intense. Operators must always be conscious of the primary responsibility, which is the safe operation of the boat and the safety of passengers and other boats in the area.

Always make sure the helm is properly manned and is never left unattended while trolling. If the boat is equipped with a tower, exercise caution and sound judgment whenever someone is in the tower. Remember, weight in the tower raises the boat's center of gravity and the boat's motion is greatly exaggerated for the person in a tower.

An operator fishing in an area that is crowded with other fishing boats may have difficulty following the rules of the road. This situation can become especially difficult when many boats are trolling. Being courteous and exercising sound judgment is essential. Avoid trying to assert the right-of-way and concentrate on staying clear of other boats. Prevent the boat from becoming entangled in lines and from cutting into lines. Also keep in mind that fishing line wrapped around a propeller shaft can damage seals in the engine lower unit.

There is currently a tremendous drain on our fishing resources. Excessive fishing and hunting, as well as pollution, have strained the fish and game population. Help out by keeping only what you will eat; practice catch-and-release and obey bag limits.

### Monofilament Fishing Line

Wildlife can experience harm from becoming entangled in or ingesting monofilament fishing line if it is left in the water or on shore. Line in the water can also endanger swimmers and divers and become tangled in boat propellers, causing damage. It can last for years in water, posing a threat for a long time. Fishing line can remain a problem even if put in the trash, because birds can take it from an open bin and become entangled or it can entangle wildlife at landfills.



Many states and private boating/wildlife organizations sponsor programs to collect used line for recycling into new products. Operators who carry used line or happen upon it while boating can dispose of it in recycling bins located at many marinas, launches, tackle shops and state service centers.

## WAKE

Boat owners/operators are responsible for the wake the boat creates. Regulations may vary from state to state. Contact local and state boating authorities for specific information, as owners/operators may be responsible for any damage or injury their wake causes. Always be alert for no-wake zones and be courteous of others while boating. Excessive and unexpected wakes can cause dangerous and even life-threatening situations.

## NOISE

Boat owners/operators are responsible for the noise the boat creates. Many state and local boating authorities enforce noise limits that may restrict engine noise, radio volume or even loud talking. Regulations may vary from state to state. Contact local and state boating authorities for specific information.

## SPEED

Boat owners/operators are responsible for maintaining the boat under control at a safe speed. Many state and local boating authorities enforce speed limits. Regulations may vary from state to state. Contact local and state boating authorities for specific information.

## SHALLOW WATER BOAT STABILITY

Boat designs for flats, bays, poles and skiffs are very similar. Because of the unique requirements for a shallow draft, stability issues can arise under certain conditions, especially during quick turns. Take time to learn the characteristics of the boat alone and in open water away from other boaters. Make gradual increases in speed and radius to get the feel of stability under various conditions and be ready to make adjustments quickly. Slow down when boating with passengers to avoid possible ejection from the boat.



## PROTECTING THE ENVIRONMENT

Our lake, river and ocean resources must be protected to be enjoyed by future generations. Boat owners/operators are responsible for protecting the natural environment and wildlife by keeping waterways clean.

U.S. waters are covered by several water pollution regulations administered by numerous federal and state agencies. Laws vary between local, inland, coastal, ocean and international waters. Laws can be enforced by local and state authorities as well as the USCG. For recreational boats, U.S. Federal Water Pollution Control, Oil Pollution Control and Refuse Acts cover U.S. waters, and the MARPOL treaty covers international waters. In any case, pollution prevention centers around three areas:

- Sewage pollution
- Garbage (solid waste) pollution
- Oil pollution

As a boater, make it a point NOT to dump or discharge ANYTHING into waters and tell passengers to respect this rule. Return all trash after boating and dispose of it properly on shore.

### DISCHARGE OF OIL PROHIBITED

The Federal Water Pollution Control Act prohibits the discharge of oil or oily waste into or upon the navigable waters of the United States, or the waters of the contiguous zone, or which may affect natural resources belonging to, or under the exclusive management authority of the United States. If such discharge causes a film or discoloration of the surface of the water, or causes a sludge or emulsion beneath the surface of the water. Violators are subject to substantial civil penalties and/or criminal sanctions including fines and imprisonment.

KC-6020



## AQUATIC INVASIVE SPECIES (AIS)



KC-6027

Aquatic Invasive Species (AIS) are plants and animals that occur in waters in which they are not native and whose introduction causes or is likely to cause economic or environmental damage or harm to human health. AIS have a negative impact on the waterway, its native species, and recreational and commercial uses of the waterway. As responsible boaters and citizens, each boat owner should do their part to prevent the spread of these aquatic hitchhikers.

In many cases, it is also required by law. Check local regulations for any waterway where you will boat.

After each boating trip, follow these three simple steps before you leave the water access to stop the spread of AIS: Clean, Drain, and Dry. This is the boater's way to help protect the environment from the damage that AIS can cause.

### Clean

- Inspect and remove all aquatic plants, animals, mud, and debris from the boat, engine, trailer, anchor, and any watersports equipment.
- Rinse, scrub or wash, as appropriate, away from storm drains, ditches, or waterways.
- Rinse watercraft, trailer, and equipment with hot water, when possible.
- Flush motor according to owner's manual.

### Drain

Completely drain all water from the boat and its compartments, including but not limited to the bilge, wells, lockers, ballast tanks or bags, bait containers, engines, and outdrives.

### Dry

Allow the boat to completely dry before visiting any other bodies of water. Water-borne organisms cannot survive long periods of dryness.

**NOTE** — Some localities may require inspection or decontamination before and/or after launching. Check state and local laws and regulations for requirements prior to traveling to go boating.



SECTION  
**3**

# BOATING REGULATIONS AND YOUR RESPONSIBILITIES

## PAINTS

Boat owners are responsible for the environmental regulations that may govern the use of antifouling paint. If the boat is kept in water where marine growth is a problem, the use of antifouling paint may reduce the growth rate. Regulations may vary from state to state. Contact local and state boating authorities for specific information.

## CLEANING AGENTS

Boat owners are responsible for the environmental regulations that may govern the use of cleaning agents. There are many “green” cleaner choices available for most any material on the boat. If using household cleaners, use them sparingly and never discharge them into waterways. Do not mix cleaners and be sure to use plenty of ventilation in enclosed areas. Avoid using chlorine, solvents and products that contain phosphates, as well as non-biodegradable or petroleum-based products. Regulations may vary from state to state. Contact local and state boating authorities for specific information.

## EXHAUST EMISSIONS

Boat owners are responsible for the exhaust emissions from the boat. Increased exhaust (hydrocarbon) emissions, which are regulated by the EPA, pollute the water and air. Contact the dealer and the engine manufacturer for more information. Additional restrictions may apply and vary from state to state. Contact local and state boating authorities for specific information.



# Section 4

## EMERGENCIES

Be prepared to deal with emergencies before they happen. Try to formulate a plan for each type of emergency in advance in order to make decisions quickly and without hesitation. Precious moments lost can mean the difference between losing and saving a life.

Before operating the boat, review *Safety in Section 2*.

### FIRST AID / MEDICAL EMERGENCIES

Every second counts toward preventing injury or death in case of a medical emergency. Boaters must have proper training and take necessary preventive measures to properly assist in times of need. Carrying an adequate and current first aid kit is critical in the immediate response and care of someone in need of medical attention. Always have dry blankets readily accessible to help prevent hypothermia. For additional information on medical, first aid and safety training such as CPR, contact your state and local authorities, or visit the Red Cross website:

<http://www.redcross.org>.

### EMERGENCY PREPARATION CHECKLIST

In addition to a safety equipment list, have an emergency checklist on board to assist in times of emergency. Use the following topics as a guideline to develop a list of emergency procedures and instructions for the use of visual and audible distress signaling devices, radios, first aid kits and all related information that could assist you or others in the event of an emergency.

### USING DISTRESS SIGNALS

Ensure all passengers understand how to operate all onboard visual and audible distress signaling devices and communication equipment. Keep all distress signaling devices and communication equipment in a readily accessible area and within immediate reach at all times. Seconds count during emergencies. Knowing the proper way to use the distress signaling devices aboard the boat can help save lives.

See the *Markers, Warnings and Advisories* section of this manual for more signaling devices.

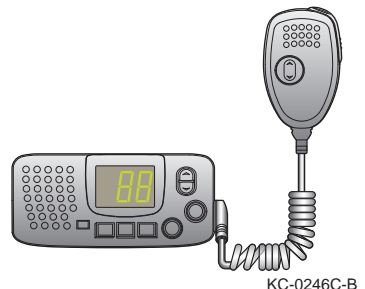



If your boat is equipped with a VHF radio, there are three primary distress calls:

- **MAYDAY radio call** – A mayday call is reserved for life-threatening situations, such as fire, severe weather or sinking, where lives are in imminent danger or the boat is in danger of sinking. Start the broadcast clearly and calmly with **“Mayday - Mayday - Mayday.”**
- **PAN-PAN (pahn-pahn) radio call** – A pan-pan call is used for urgent but non-life-threatening situations where there is no immediate danger to lives or the boat, such as a loss of steering control or taking on water of any amount. Start the broadcast clearly and calmly with **“Pan - Pan - Pan.”**
- **Securite (se-cure-ih-tay) call** – A securite call is used for non-life-threatening situations to notify authorities and others in the vicinity of important navigation and weather alert calls. Start the broadcast clearly and calmly with **“Securite - Securite - Securite.”**

In an emergency situation the responder needs to know four important pieces of information:

- The exact nature of the emergency and an assessment of the severity
- Number of people on board
- The location (navigation marker, visual reference or GPS coordinates in open water)
- What the boat looks like (hull and top colors, unique features, flags, etc.)

For additional information on the safe and proper use of distress signaling devices and the safe and proper use of emergency communication equipment, contact state and local authorities. Additional information can be found on the USCG website:

<http://www.uscgboating.org>.

## REQUESTING ASSISTANCE (NON-DISTRESS CALL)

If a boater contacts the USCG on Channel 16 VHF-FM or Channel 70 DSC regarding a non-distress situation, the USCG will offer to contact any assistance provider (commercial or friend) the boater requests or will issue a Marine Assistance Request Broadcast (MARB) if the boater has no preference of service.



## FIRE AND EXPLOSION



### WARNING

*Fire/Explosion Hazard: Gasoline is extremely flammable and highly explosive under certain conditions.*

- Do not smoke or allow open flames or sparks nearby when refueling.
- Do not store fuel in any containers or compartments which are not designated for fuel storage.
- Static electricity can be generated while fueling and can cause a fire or explosion. To prevent electrostatic spark when refueling, make sure the nozzle is in contact with the fill pipe at all times.
- Avoid damaging fuel lines and connectors and make sure fuel does not contact hot engine parts.
- Do not confuse the fuel fill deck plate with the water or waste fill plates, if equipped. All deck plates are properly labeled. If fuel is accidentally pumped into any other deck plate, do not attempt to pump it out. Water and waste pumps are not designed to pump fuel and a fire or explosion could result. Contact the dealer to have the fuel professionally removed.
- USCG-approved fire extinguishers are required on all Class I, II and III boats.

A fire or explosion may occur when least expected. The decision to abandon the boat or stay to fight the fire is difficult and depends on many factors. Formulate a fire plan in advance to make that decision quickly and without hesitation. Keep in mind the following guidelines:

- Many fires are the result of gasoline and oil accumulating in the bilge, careless fueling practices and electrical problems. In the event of a fire, try to stop the boat and turn off the engine as quickly and safely as possible. Immediately use a fire extinguisher at the base of the flames in a sweeping motion to reduce or extinguish the fire. Ensure that all passengers are safe from immediate danger and are wearing life jackets. If the fire is located in the engine compartment (if equipped), make sure the bilge blower (if equipped) is off and do not open the engine cover.
- Once the fire is extinguished, check for other immediate fire threats and personal injuries and call for assistance immediately.

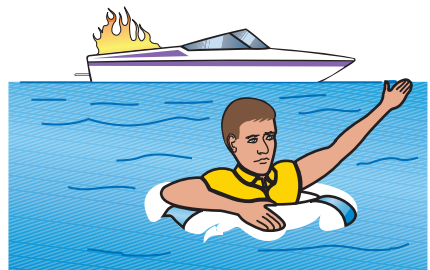

KC-0252C-A



- If you are unable to easily extinguish the fire, or if the fire is uncontrollable, attempt to get yourself and all passengers off the boat and into the water. If possible, ensure that all passengers are wearing life jackets or have access to one by the time they are in the water. Before leaving the boat, if possible, verify that there is no immediate danger of fuel sitting or burning on the water's surface where you and your passengers will be floating. Immediately swim to a safe position upwind from the boat and use distress signals to get assistance.

## MAN OVERBOARD (MOB)

A high percentage of boating fatalities are the result of people falling overboard, many of whom were not wearing life jackets. If someone falls into the water unexpectedly, react quickly, as every second counts toward preventing injury or death. Keep these guidelines in mind:

- Brief passengers before leaving the dock on the proper procedures should someone fall overboard. Add this briefing to the passenger safety equipment overview.
- At the first sign that a person has fallen overboard, loudly yell “man overboard” and state which side of the boat such as “man overboard—port!” In heavy seas, throw a floatable item toward the MOB as quickly as possible to serve as a marker.
- The operator should immediately reduce speed and determine whether or not to come to a full stop or circle around.
  - If stopped, throw a flotation device (a throwable type is best, but any can be used) to the victim, shut down the engines, and throw the victim a line if necessary.
  - If circling around, assign one passenger to throw a flotation device as a marker, keep the victim in sight and continuously point to the victim. Carefully navigate back to the victim, staying at a safe distance, and position the boat safely to retrieve the victim. Keep current, wind and waves in mind so the victim drifts toward the boat. Shut down the engines and throw the victim a line if necessary.
- Move passengers to the rescue side of the boat to assist the victim back into the boat.
- Avoid going into the water to assist the victim unless there is no other way to retrieve the victim. If a rescuer must go into the water, the rescuer should be wearing a life jacket. The rescuer should also be prepared for the possibility of being pulled under water by the victim if the victim is panicking.



## CAPSIZING AND FLOODING

A boat may capsize or flood when least expected. Formulate a plan in advance in case of capsizing or flooding. Review the following guidelines:

- If the boat capsizes, locate all passengers and guide them to a safe flotation device or the forward hull if the boat is floating upside down.
- If possible, provide life jackets to all persons in the water and assess them for alertness and injuries.
- **STAY WITH THE BOAT!** Climb up on the hull and try to get assistance.
- Do not try to swim to shore, as it can be farther than it appears.

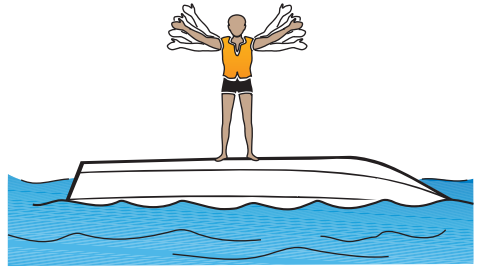

KC-0013C-A

If the boat starts to flood, slow the boat to a safe speed and stop as quickly as possible. Activate the bilge pump(s) immediately. Try to locate the cause of the flooding. If the cause is not readily apparent or not easily corrected, head for shore or shallow water as quickly as possible and call for help.

## RUNNING AGROUND

When a boat runs aground, the stop is usually abrupt. Because passengers are not secured to a seat, abruptly stopping a boat while in motion can cause serious personal injury or even death. First, turn off the engine(s) immediately, locate all passengers and attend to any injuries, calling for emergency assistance as needed. Then, assess the damage to the boat and determine if there are any other immediate threats such as water leaking into the boat, or fuel or flammable materials leaking into the water or inside the boat. Immediately call for assistance if threats exist that could endanger the safety of passengers.

If there are no immediate safety threats to passengers and the boat is not damaged, attempt to propel it away from the obstacle. If the engine or drive system has been damaged and the engine restarts, be aware of excessive vibrations or uncommon noises, which usually indicate damage to the drive system. If this is the case, it is not safe to proceed. Call for emergency or professional towing assistance immediately.

**WARNING**

**Personal Injury Hazard: DO NOT attach tow lines to cleats, watersport line point, or eyes used for docking; use only designated strong points. Death or serious injury could occur if lines and/or hardware fail while they are under extreme tension.**

If the engine restarts and the boat can be navigated safely back to port, proceed slowly to port and be ready to call for emergency assistance if needed. Even if the boat and engine appear to be in good operating condition after running aground, have the boat inspected by a qualified marine technician BEFORE returning it to service. Damage may have occurred that is not obvious to you as an operator.

## DANGEROUS WEATHER

Take special precautions when encountering or operating in dangerous or hazardous weather conditions.

See the *Severe Weather* section of this manual for additional information.

## ENGINE OR BOAT SYSTEM FAILURE

In the event of an engine or boat system failure and when not in immediate danger, try to troubleshoot or identify the problem before calling for assistance.

See the *Troubleshooting and Service Requirements* section of this manual for additional information.

## ACCIDENTS, COLLISIONS AND GIVING ASSISTANCE

A collision or accident may occur when least expected. Formulate a course of action in advance in case of a collision or accident. Keep in mind the following guidelines:

- If an accident or collision occurs involving the boat, locate all passengers first and verify and secure their safety. Check for injuries and provide all passengers with a flotation device.
- After determining that passengers are not in danger, provide assistance to passengers on the other boat.
- Immediately call for help and then assess the damage to the boats. Render necessary assistance to prevent further damage or personal injury.

The USCG requires the owner/operator of a boat involved in an accident to report the incident immediately to the proper marine law enforcement agency for the state in which the accident occurred.



See the *Reporting Accidents* section of this manual for additional information.

An operator who witnesses or is aware of an accident or collision while boating must report it immediately and provide assistance.

Operators seeing a distress signal or suspecting a boat is in trouble must assume it is a real emergency and render assistance immediately. After determining that a real emergency exists, call for help immediately and then provide assistance to all passengers to ensure their safety.

## TOWING ON THE WATER

In situations where an operator is asked to tow or be towed for any reason, assess the situation and try to contact a professional towing service or other emergency assistance first. When encountering a boat in distress, always offer emergency or safety assistance and/or call for assistance for the distressed parties if necessary. Towing or being towed presents an increased risk of personal injury and boat damage.

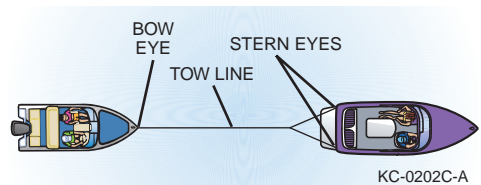

**⚠️ WARNING** *Personal Injury Hazard: DO NOT attach tow lines to cleats, watersport line point, or eyes used for docking; use only designated strong points. Death or serious injury could occur if lines and/or hardware fail while they are under extreme tension.*

Follow these guidelines when towing or being towed:

- Use extreme caution when throwing weighted lines to a boat in distress. When in rough seas, use a light throwing line with a weight secured on the throwing end and a heavier towing line secured to the other end.
- Never attempt to tow a boat larger or heavier than your own.
- Never attempt to tow a grounded, damaged or capsized boat.
- Use a tow line that is rated at least four times the gross weight of the boat being towed.
- Make sure tow lines are in good condition and are free of damage, cuts or abrasions.
- Attach a tow line to the designated strong point on the disabled boat. Never attach a tow line to any point on the disabled boat other than the designated strong point. Strong points are typically the bow and stern eyes on boats under 26' and are usually labeled.



- When attaching to the stern strong points, wrap the tow line with chafing gear where it rubs against the boat or any corners.
- Leave at least two boat lengths between the boats for adequate movement.
- Never allow anyone to be in line with the tow line. If the line breaks, pulls free or the hardware fails, dangerous recoil could occur, resulting in severe injury or death to anyone in its path.
- Adjust the tow line to match wave action. Keep the boats on the crest or in the trough of the waves at the same time. In protected, calm waters, shorten the line for better handling.
- Tow at moderate speed, allowing for adverse wind and wave conditions.
- Have the operator of the towed boat steer with you if possible.
- Have a person on the tow boat watch the disabled vehicle and, if necessary, be available to signal the operator of the disabled boat.

Check with local and state authorities prior to towing for additional regulations and restrictions on towing other boats or equipment.

## LAW OF SALVAGE

If boaters require assistance while cruising in the Great Lakes, coastal or ocean waters, they should use caution **before** allowing any towing company or private agency to pass a line to the boat. The law of salvage says, among other things, *“...any vessel, if rendered assistance from a towing company or private agency, can be forced to relinquish a portion of the vessel’s worth for the assistance received.”* While this is very rare with recreational boats, it can happen.

Before taking the line boaters must establish that they do not agree to any salvage rights and wish to be assisted on a contract basis. Boaters must then establish the contract price and payment terms. Boaters should accept the tow line only when the captain of the company/agency acknowledges the contract price and payment. Most tow companies are reputable and post terms and pricing on their websites.

If boating in the Great Lakes, coastal or ocean waters, it is a good idea to have a membership in a national towing service. This membership can significantly reduce the costs of towing if ever needed.





## HURRICANE AND SEVERE WEATHER PREPAREDNESS

If keeping the boat in a region susceptible to hurricanes or severe weather (such as in the Great Lakes), have a well-thought-out plan for the boat long before the season starts. Consider the following:

- Boaters new to the area should talk to neighbors and local officials on what to expect.
- Boaters should talk to the dealer and marina about supplies, equipment and services available.
- Assemble the boat, contacts and insurance information and copy documents for safekeeping.
- If keeping the boat on the water, prepare a hurricane mooring package with extra lines, fenders and chafing protectors, as it is usually the boat owner's responsibility to provide mooring gear in a marina. Plan on doubling the normal lines (bow, stern and spring) and fenders as a minimum. Remember, once a hurricane watch is posted, the local supply of lines and fenders will be quickly depleted.
- Remove electronics, canvas and loose items such as fighting chairs.
- Remove flammable, explosive or hazardous materials.

## PROTECTING THE BOAT FROM THEFT

Thefts of boats, propulsion units and electronics are on the rise due to the high values and easy resale. While thieves still target boats on trailers at homes or on lake properties, marinas, storage facilities and dealerships are now being targeted because of the concentration of high-quality outboards and electronics available. Consider the following to make it difficult for thieves:

- Remove expensive electronics or cover with a sturdy, lockable cover.
- Use locking devices on outboard motor mounts and propellers.
- Use security fasteners that require a special tool for removal when mounting devices.
- Survey the marina or storage facility for obvious security lapses. Discuss concerns with personnel or find a new location.
- Talk to neighbors at home or the marina/storage facility and provide them with a cell phone number and other contact information.
- If leaving the boat in the water, install a boat monitoring system with GPS tracking. Many propulsion unit manufacturers now offer this as an option on boats with electronic controls.
- Consult an insurance agent and local authorities for more recommendations.



SECTION

**4**

# EMERGENCIES

This Page Intentionally Left Blank

# Section 5

## OPERATING IN HAZARDOUS CONDITIONS

Before operating the boat, review *Safety in Section 2*.

### SEVERE WEATHER

Getting caught in severe weather can be dangerous and even fatal. Check with local weather stations, the USCG or weather-service broadcasts (162.55 or 162.40 MHz) for the latest conditions. Check the weather not only before you go out on the water, but also periodically while you are on the water. Consult the following websites for weather information:

- [www.weather.com](http://www.weather.com)
- [www.weather.gov](http://www.weather.gov)
- [www.navcen.uscg.gov](http://www.navcen.uscg.gov)

Enable National Oceanic and Atmospheric Administration (NOAA) weather alerts on radios, phones and other electronic devices for advance warnings. If weather is approaching, instruct all passengers to wear a life jacket; close all windows, hatches and doors; remain seated; use handholds and seek shelter in a safe harbor.

### STORM CONDITIONS

Take the following precautions if operating the boat in storm conditions:

- Have all occupants wear life jackets.
- Turn on navigation lights.
- Locate and have inclement weather gear and safety equipment ready.
- Mark or identify the boat's position.
- Close all ports, stow all gear and secure any loose equipment on deck.
- Reduce speed and head for port or a safe, easily reachable place.
- Keep a lookout for debris and obstructions in the water.
- When possible, head into the waves at a 45-degree angle. Allowing high waves to strike the side of the boat may cause it to capsize or swamp.
- If losing power, keep the boat headed into the waves by rigging a sea anchor off the bow.
- If a storm cell with lightning cannot be avoided, lower antenna and take down fishing poles.



## FOG CONDITIONS

Avoid operating the boat in foggy weather, if possible. Operators encountering fog conditions should return to port immediately. Also, take the following precautions:

- Reduce speed to a safe speed or idle.
- Take bearings and log the course and speed before the fog sets in. Use of a GPS is recommended.
- Have all occupants wear life jackets.
- Assign lookouts to the bow and stern to keep watch and listen.
- While navigating in fog, sound a five-second blast from the horn or whistle once every two minutes to alert other boaters of your position.
- If it is unsafe to continue navigating the boat, quickly find the best position to anchor. Sound a five-second blast from the horn or whistle once every minute while anchored to alert other boaters of your position.

## REDUCED VISIBILITY

Natural environments and inclement weather can cause reduced visibility. Storm condition hazards can be compounded by reduced visibility while on the water. Always use common sense and take safety precautions if operating the boat in reduced visibility conditions.

## COLD WEATHER

Avoid operating the boat in cold water or weather conditions, and never operate in frozen or icy waters. Operating in these conditions significantly increases the risk of serious injury or death. Boating in these conditions can lead to cold-water immersion, shock or hypothermia. Weather conditions may hinder emergency rescue or assistance, and cold weather poses potential problems for onboard equipment, as well as the engine. See the *Engine Operator's Manual* and the equipment manufacturer's instructions for operating in cold weather.

## WATER HAZARDS

Every waterway poses hazards that operators must be aware of and avoid. These hazards include shallow water, rocks, tree stumps, sandbars and submerged/semi-submerged cables and pipes. Ask local authorities and other boaters for information and consult a marine chart when boating on unfamiliar waters. As a boat operator, try to avoid all hazards, known and unknown.



## AQUATIC VEGETATION / WEEDS

Operating in weeded areas can be hazardous. Aquatic vegetation can be a threat to the boat's drive system. Vegetation and weeds can wrap around the propeller, causing loss of propulsion and steering control. They may also restrict the engine water cooling intake, causing the engine to overheat. Avoid operating in or near vegetation. If restricted because of vegetation, stop the engine. See the *Engine Operator's Manual* for recommendations on the removal of vegetation from the propeller and water cooling intake ports. Be extremely careful and never get into the water when clearing the propeller. Stay out of the water in highly congested vegetative areas, which can severely restrict your mobility and create a life-threatening situation.

### NOTICE

*Vegetation can sometimes be removed by shifting to NEUTRAL, pausing a moment, then shifting to REVERSE to unwind the vegetation from the propeller.*

## DAMS AND SPILLWAYS

The waterways around dams and spillways are extremely hazardous. Dams and spillways are subject to rapid water flow changes, and may have floating and sunken debris in the nearby water. These areas are often marked as restricted, and it is best to always stay clear of them.

## SHALLOW WATER OPERATION



### WARNING

***Collision Hazard: Use caution in shallow water or where underwater/floating objects may be present. Hitting an object at high speed or severe angle can seriously injure people and damage the boat.***

Operating in shallow water presents a number of hazards. Sandbars in narrow inlets are constantly shifting, making it difficult to mark them with buoys. Sandbars are sometimes indicated by waves as they form into breakers when passing over the sandbar. In coastal areas, tides can affect water level as much as 30 feet (9 meters). Check with local marinas or Coast Guard stations for tide tables and current charts.



## MARKERS, WARNINGS AND ADVISORIES

Find out from local authorities if hazards exist in areas where you intend to navigate, and know how these hazards are marked. You must also recognize flag designs that indicate hazards or activities that are present and keep well clear of those areas. Always watch for swimmers and stay clear of all swimming areas, marked or unmarked.



KC-0015C-B

Become familiar with navigation markers, which identify navigable routes and indicate water hazards. Always stay within marked boundaries and steer clear of hazards.

Flags and indicators are markers of potential emergencies and hazards. Become familiar with these flags and indicators. Additionally, understand your responsibilities when operating at these times and in these areas.

## BOAT FLAGS

DIVERS FLAG



USED BY  
RECREATIONAL  
DIVERS -  
INDICATES  
DIVER'S  
POSITION

ALPHA FLAG



WORLDWIDE VESSELS  
ENGAGED IN DIVING  
OPERATIONS - DOES  
NOT INDICATE  
DIVER'S POSITION

DISTRESS FLAG



INDICATES  
FELLOW  
BOATER IS IN  
NEED OF  
ASSISTANCE

SKIER DOWN FLAG



INDICATES  
SKIERS IS DOWN







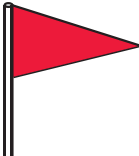

KCB-0013

Storm warning advisory flags and indicators alert boaters to impending weather conditions. Become familiar with these flags and indicators and understand the potential hazards associated with operating in these conditions.

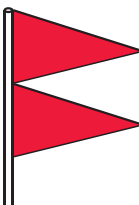

# OPERATING IN HAZARDOUS CONDITIONS

## HARBOR FLAGS AND INDICATORS

DAYTIME WARNING	DESCRIPTION	NIGHTTIME WARNING
	<b>Small Craft Advisory</b> - Winds greater than 18 knots, sustained for two hours or more or hazardous wave conditions. Following a storm, hazardous wave conditions can persist long after the high winds have subsided.	
	<b>Gale Warning</b> - Sustained winds (2 or more hours), of 34-47 knots.	
	<b>Storm Warning</b> - Sustained winds of 48 knots or greater.	
	<b>Hurricane Warning</b> - Forecast winds of 64 knots and above. Displayed only in connection with a hurricane.	

 Actual Signal in red

KC-0371C



SECTION

# 5

## OPERATING IN HAZARDOUS CONDITIONS

This Page Intentionally Left Blank



# Section 6

## NAVIGATION RULES AND AIDS

Before operating the boat, review *Safety in Section 2*.

The following information outlines basic navigational rules. Boating regulations are enforced by USCG, state and local authorities. You are subject to marine navigation regulations for both federal and state waterways. For more information, contact the USCG, state and local marine authorities. The navigational rules for U.S. waterways can be found in the “Navigational Rules” publication. This publication can be found at most marine supply stores, or you may contact the USCG or visit:

[www.navcen.uscg.gov](http://www.navcen.uscg.gov) to view or download the publication.

### RULES OF THE ROAD

#### RIGHT-OF-WAY

Boats with less maneuverability have right-of-way over more agile boats. You must stay clear of a boat with right-of-way. Examples of boats with right-of-way are:

- Boats aground or not under command
- Boats with restricted maneuverability
- Boats engaged in fishing
- Non-motor boats (having no power propulsion), i.e., rowboats, paddle boats, canoes and sailboats

Small pleasure boats must yield right-of-way to large commercial boats in narrow channels. A boat with right-of-way is sometimes referred to as the privileged boat.

#### The General Prudential Rule

The general prudential rule regarding right-of-way is if a collision appears unavoidable, neither boat has right-of-way. Both boats must act to avoid collision.



## CROSSING

In crossing situations, the boat to the right from the 12 o'clock to the 4 o'clock position has the right-of-way and must hold course and speed. The boat without right-of-way must yield and pass to the stern of the privileged boat. Boats going up and down a river have the right-of-way over boats crossing the river.

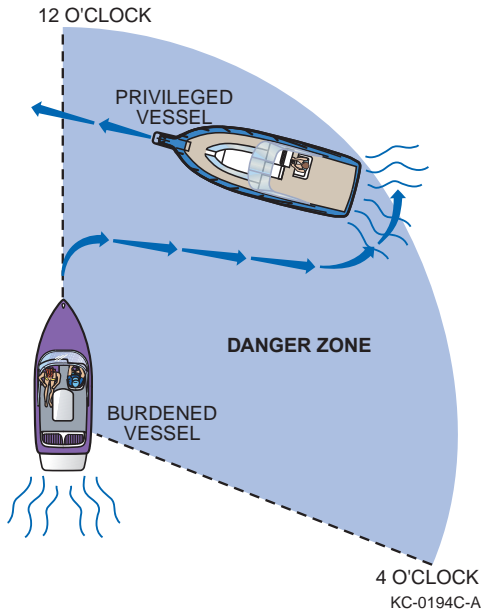

# NAVIGATION RULES AND AIDS



## MEETING HEAD-ON

When two boats meet head-on, neither boat has the right-of-way. Both boats should decrease speed, turn to the right and pass port to port. If, however, both boats are on the left side of a channel, each vessel should sound two short horn blasts and pass starboard to starboard.

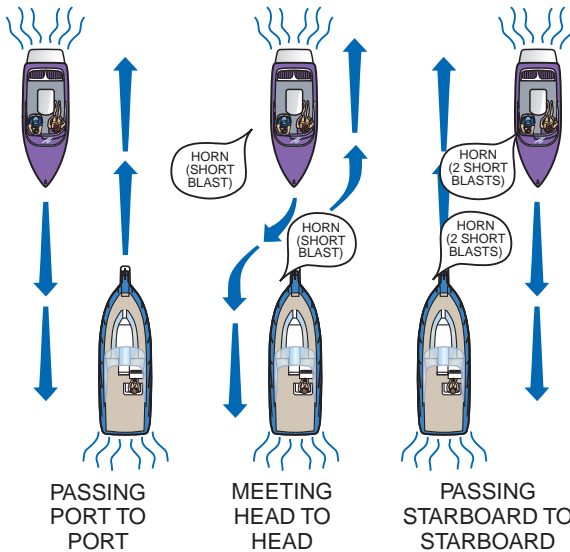

KC-0195C-B



## OVERTAKING / PASSING

The boat overtaking or passing must yield right-of-way to the boat being passed. The overtaking boat must make any adjustments necessary to keep out of the way of the boat being passed. The boat being passed has the right-of-way and must hold its course and speed.

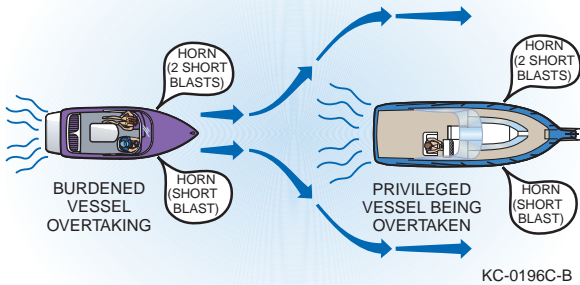

## AUDIBLE SIGNALS

It is not necessary to sound a signal every time a boat is nearby. It is typical for commercial boat operators to signal their intention, using a whistle, horn or bell, to avoid potentially confusing or hazardous situations. Privileged boat operators customarily signal first, then the yielding boat operators return the same signal to acknowledge they understand and will comply. Use the danger signal (five or more short, rapid blasts) if intent is not clear.

Use the following signal blasts early enough so other boaters notice and understand them:

AUDIBLE DISTRESS SIGNAL	DEFINITION
One long blast	Warning signal (coming out of slip or passing astern)
One short blast	Pass on port side
Two short blasts	Pass on starboard side
Three short blasts	Engine(s) in reverse
Five or more short blasts	Danger signal



## AIDS TO NAVIGATION

Learn to recognize the different buoys and day markers; they are the signposts of the waterways. The United States Aids to Navigation System (USATONS) is the primary marking system used on inland water, coastal waters and rivers. This system is maintained by the USCG.

There are two other navigation marking system variations boaters must follow in the United States:

- Western Rivers Marking System – When on the Mississippi River, tributaries above Baton Rouge, and several other rivers that flow toward the Gulf of Mexico.
- Intracoastal Waterway (ICW) – Runs just inland and parallel to the Atlantic Ocean and Gulf coasts from Manasquan, New Jersey, to the Mexican border. *Since ICW routes may travel next to non-ICW routes in opposing directions, navigate by the yellow symbols when following the ICW.*

Both systems are similar to USATONS but have subtle differences that must be understood. If you boat in these areas, visit [www.uscgboating.org](http://www.uscgboating.org) for navigation rules.

Navigational aids are designed and placed accordingly to help you navigate safely on the water. Learn to recognize the different buoys and day markers.

The following information is based on the USATONS. For further information, contact the USCG and state and local marine authorities. Also visit [www.uscg.boating.org](http://www.uscg.boating.org) for navigation rules.

The USATONS uses buoys, beacons and minor lights as markers.

NEVER tie or anchor to a navigational aid. This action is unlawful and dangerous to you, your boat and other boaters.

NEVER move or damage a navigational aid. This action is unlawful and dangerous for other boaters.

SECTION  
**6** **NAVIGATION RULES AND AIDS**

## BUOYS

Most anchored floating markers are generally referred to as buoys. Buoys have many uses and color schemes, and can vary in size and shape. The most commonly used buoy colors are white, red, green, yellow and black. Buoys may be unlighted or lighted. Some are audible; others have both an audible and a visual signal. Lights, bells and horns on buoys aid in night boating or poor visibility conditions. Buoys with unique light-flashing characteristics are identified on nautical charts with the specific flashing pattern.

Become familiar with the specific buoys used in the waters where you are boating. Contact local authorities for specific information and/or navigational aid charts for your waterways.

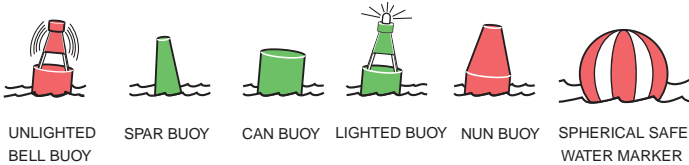

KC-0052C-B

### Mooring Buoys

The only buoys you are permitted to moor to are mooring buoys. Mooring buoys are white with a blue horizontal stripe. Check with local authorities before deploying a permanent mooring buoy. Mooring to a navigation buoy, regulatory markers or lateral markers is illegal.

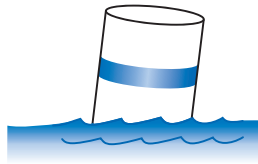

WHITE WITH BLUE BAND  
 MAY SHOW WHITE REFLECTOR OR LIGHT

KC-0020C-A



## DAYMARKS / DAYBOARDS

Daymarks or dayboards are fixed visual markers in the water. The markers are commonly attached to a post or piling and are sometimes accompanied by a light. Daymarks are either red or green and are usually triangular- or square-shaped, though their shapes can vary. Daymarks often display numbers, which act as navigation guides. Red daymarks are usually triangular and sometimes show an odd number. Green daymarks are usually square and sometimes show an even number. The numbers on the markers are sequential and increase from seaward.

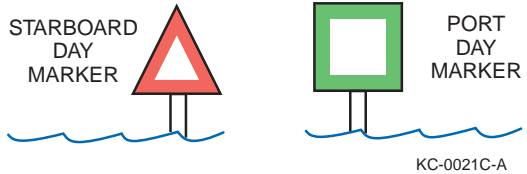

## LIGHTS AND LIGHTED STRUCTURES

Maneuvering a boat at night can be dangerous and confusing. To aid boaters with navigation and to warn of hazards, the USCG and state and local authorities maintain a variety of light structures. Some light structures are equipped with radio beacons, radar reflectors and/or fog signals.

### Minor Lights

Minor lights are colored according to the buoyage marking system in use. They are similar to lighted buoys, except they are usually higher and on more stable platforms to increase visibility. Most minor lights are part of a series to mark a channel, river, or harbor and fairways.



### Range Lights

Range lights are usually visible in one direction and help a boat operator navigate safely. Steering a course to keep range lights arranged in a line (one on top of the other) will help guide a boat through a channel.

RANGE LIGHTS

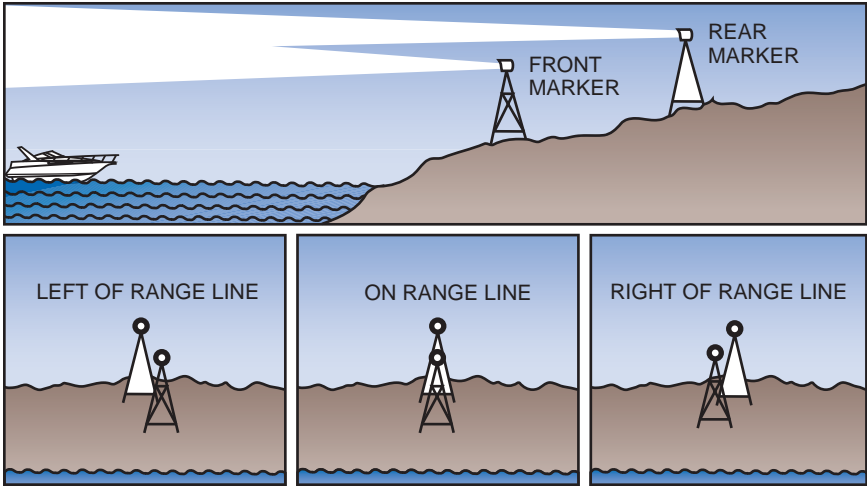

KC-0022C-A

### Lighthouses

Lighthouses can be found at harbor entrances, prominent headlands, isolated danger areas and along the coasts. These striped or patterned structures have unique flashing signals, which help boaters identify them.



KC-0023C-B





## MARKERS

Seven (7) types of markers are used to assist the boat operator:

- Regulatory
- Range
- Special
- Lateral
- Safe Water
- Preferred Channel
- Isolated Danger

### Regulatory Markers

Regulatory markers are used to display information or indicate danger. Regulatory markers can be fixed visual markers or anchored floating buoys.

Fixed visual markers are usually white with orange geometric shapes that display information. Anchored floating buoys are white cylinder-shaped buoys with orange bands at the top and orange geometric shapes that may display information.

Following are the various orange geometric shapes used on these markers:

- Diamond – Indicates danger
- Diamond with cross marks inside – Indicates that a boater must keep away
- Circle – Indicates a controlled area or speed limit
- Square – Displays important information



DANGER



BOATS  
KEEP OUT



CONTROLLED  
AREA



INFORMATION

KC-0244C-A

### Range Markers

Range markers have many color schemes, may have numbers or letters and may be lighted or unlighted. They are placed in pairs within close distance of each other. They are commonly used in channels to guide boats safely through the center or safe line of navigation. Keep range markers visually in line with each other while navigating the waterway to avoid obstacles or other invisible dangers.

SECTION  
**6** NAVIGATION RULES AND AIDS

### Special Markers

Special markers are yellow and come in various styles and shapes. Lighted and unlighted daymarks and buoys vary in function. Many are used to display information and navigational direction rules. The most common special markers are those used in intercoastal waterways. Contact your state and local authorities for more information on special markers used in your boating area.

### Lateral Markers

Lateral markers are used to mark the sides of navigable channels. They can be buoys, daymarks or minor lights, and are red and green in color. They can be lighted or unlighted and may or may not have numbers.

The basic nautical rule of lateral markers is the phrase “Red, Right, Returning.”

The term “sea” generally refers to the ocean or a large body of water. “Seaward” refers to traveling or pointing toward the sea or large body of water. “From seaward” refers to traveling from the sea or a large body of water inland or toward a smaller body of water.

When traveling seaward – keep red markers to your port (left) and green markers to your starboard (right).

When returning from seaward – keep red markers to your starboard (right) and green markers to your port (left).

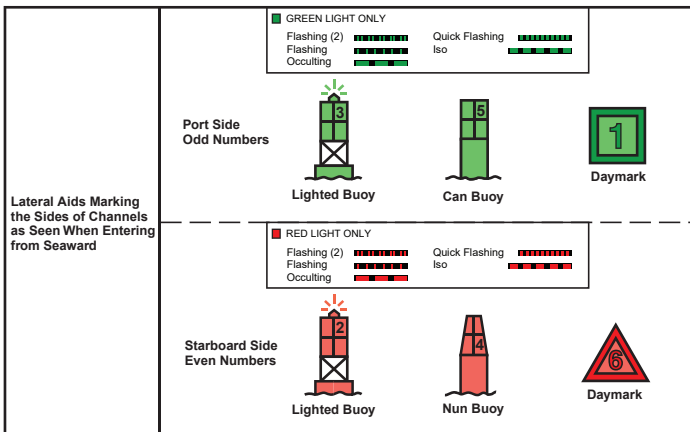

KC-0054C-A



## Safe Water Markers

Fairways and mid-channels may be marked with safe water markers or buoys. These markers indicate safe water all around. Safe water markers are red and white with vertical stripes, and are round or have a red spherical top mark.

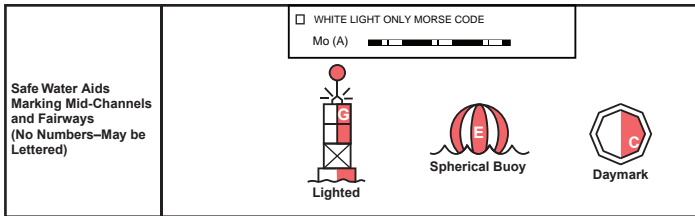

KC-0055C-A

## Other Special Signs and Markers

Various signs and markers are used throughout U.S. waterways for different purposes. In Florida, special signs are used to warn of “manatee” areas. These signs help to control speed and/or restrict areas from boating to conserve this endangered species. As a boat owner and operator, be aware of special information and markers on the waterways. Contact your state and local authorities for more information on local restricted or controlled areas and their markers.



### Preferred Channel Markers

Obstructions, channel junctions and preferred channels are marked with red and green horizontally striped can and nun-style buoys. The top band color indicates the preferred path to take. Use these markers in the same manner as lateral markers to follow preferred channels.

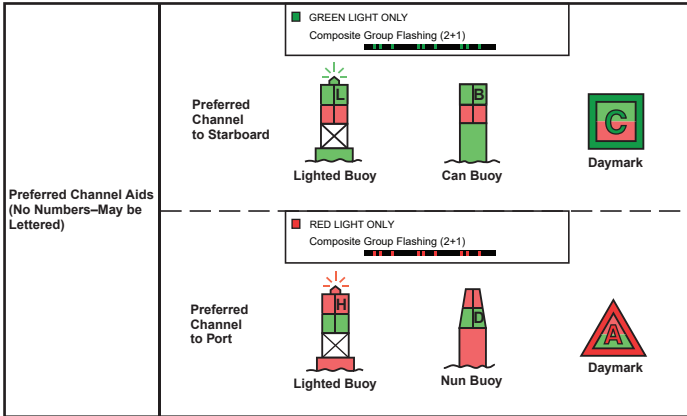

KC-0056C-A

### Isolated Danger Markers

Isolated danger markers indicate an isolated danger which may be passed on all sides. These markers are black with one or more broad horizontal red bands and are equipped with a top mark of two black spheres, one above the other. On inland waters, a buoy with alternating vertical black and white stripes may be used to indicate that an obstruction or other danger exists between the buoy and the nearest shore. Do not pass between the buoy and the shore.

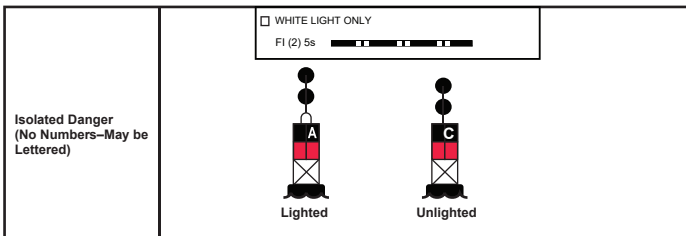

KC-0057C-A



## NAVIGATIONAL LIGHTS AND NIGHT OPERATION

Navigational lights are intended to alert other boats to your presence and course and their use is essential to boating safety and the prevention of collisions. Knowledge of navigation lights is necessary for the boat operator.

Regulations require that navigational lights be clearly lit and properly displayed at all times between sunset and sunrise, and always when operating in reduced visibility. Where applicable, lights must appear on the sides, stern, masthead and all-around positions. While underway, especially in congested areas, turn off any show lighting and lighted accessories.

All navigational rules apply at night, but speed is restricted on many waterways. Night boaters must operate at a slow, safe speed and stay clear of all boats, regardless of which boat has right-of-way.

Protect your night vision by avoiding bright lights and dimming courtesy lights. If possible, have a passenger help keep watch for other boats, water hazards, and aids to navigation.

The size, speed and direction of other boats are determined at night by white, green and red running lights.

- A green light indicates the starboard side of the boat. Generally, if you see a green light on another boat, you have the right-of-way. Hold your course.
- A red light indicates the port side of the boat. Generally, if you see a red light on another boat, they have right-of-way and you must yield your course.
- If you see both red and green lights, this indicates the boat is pointed towards you. Reduce speed and give a wide berth, usually on your port.
- A white light alone with no visible red or green lights indicates a boat at anchor and not making headway or a non-powered craft. Reduce speed and give a wide berth.

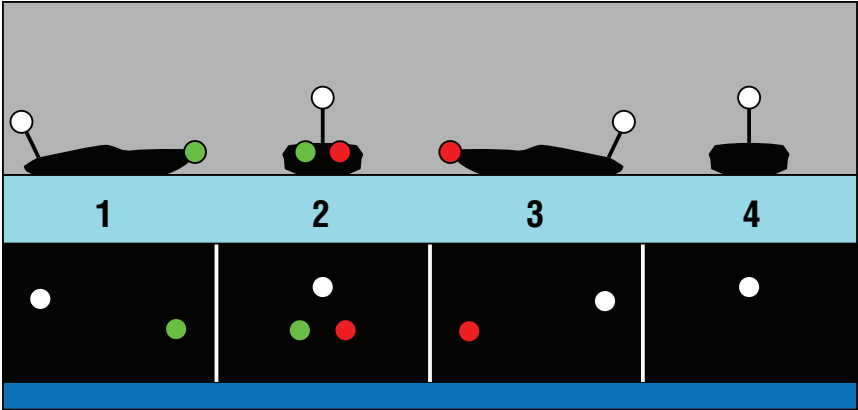

KCB-0104

1. Starboard Side; boat moving to the right
2. Bow; boat moving towards you
3. Port Side; boat moving to the left
4. Stern; boat anchored, non-powered or moving away

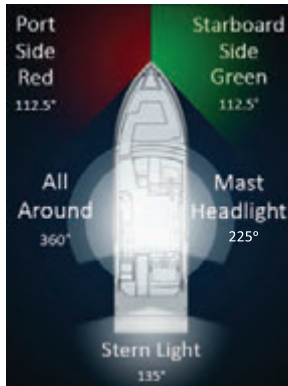

KCB-0105

# Section 7

## FEATURES

### GENERAL LAYOUTS

The general layout illustrations show all components or accessories that may not be included on your Tigé boat.



### DASH PANELS

The Dash Panel illustrations are used to help you identify the location of switches, controls, ports, gauges and V-drive indicator. Your boat may not be equipped with all of the features or options.



## TIGÉ CLEAR DASH

1. Wireless Phone Charger/Cradle
2. AUX/USB Port
3. Thruster Volt Meter
4. Steering Tilt Lever
5. Tigé CLEAR
6. Fuel Gauge
7. Tachometer
8. Speedometer
9. Oil Temperature/Pressure and Battery Gauge
10. Ignition Key Switch and Horn
11. TAPS Rocker Switch
12. Safety Lockout Ring (Shift Lockout)
13. Shifter/Throttle Control Handle
14. Emergency Stop Switch
15. Neutral Throttle Button

## SWITCHES, CONTROLS, PORTS, GAUGES AND INDICATORS

### BILGE (BILGE PUMP)

This switch operates the bilge pump to remove excess water from the bilge area of the boat manually. When the switch is pressed on, the bilge will turn on. When the bottom is pressed off, the bilge will turn off.

Depending on model, your Tigé boat may be equipped with one or two automatic bilge pump(s) which detect excess water accumulation and will turn the bilge pump on automatically. The switch does not have to be on for the automatic system to work. This switch can also be used to test the bilge pump, by listening to hear that the pump is operating. It may not pump water unless water is present. Do not operate the bilge pump continuously when it is dry.

Inspect the bilge area frequently for evidence of excessive water. Continuous operation of the bilge pump can mean there is excess water in the bilge. Test the bilge pump at regular intervals. Debris can also prevent the pump from operating or make it operate continuously. Make sure no debris is blocking the bilge pump float. See your Tigé dealer if you have any questions.





## BLOWER (ENGINE COMPARTMENT / BILGE AREA BLOWER)

This switch operates the engine compartment ventilation blower to remove explosive fumes from the area. When the blower switch is pressed on, the blower will turn on. When the blower switch is pressed off, then the blower will turn off. The blower must be operated for a minimum of four minutes before starting the engine. Also, the blower should be operated continuously when at idle or running at slow speeds.



### **DANGER**

*Gasoline vapors can explode, resulting in serious injury or death.*

- *Before starting engine, check the engine compartment for gasoline or gasoline vapors, then run blower for 4 minutes.*
- *Run blower below cruising speed.*

## COURTESY (COURTESY LIGHTS)

This switch operates the courtesy lights. When the switch is pressed on, the lights will turn on. When the switch is pressed off, then the lights will turn off.

## DOCKING (DOCKING LIGHTS)

This switch operates the docking lights. The docking lights are to be used for docking only; DO NOT use them while cruising. When the switch is pressed on, the lights will turn on. When the switch is pressed off, the lights will turn off.

## NAV (NAVIGATION LIGHTS)

This switch operates the navigation lights. When the switch is pressed on, the lights will turn on. When the switch is pressed off, then the lights will turn off.

## EMERGENCY STOP SWITCH



### **WARNING**

*Loss of Control and Unsafe Boat Hazard: An emergency stop switch system that is not used or does not function properly can cause death or serious injury. DO NOT operate the boat if the emergency stop switch system does not function properly.*

The emergency stop switch will stop the engine when the lanyard is pulled far enough to disconnect the clip from the switch. Attach the lanyard to the boat operator whenever the engine is running, but be aware of loss of engine power if the switch is activated.



If the operator is thrown from the seat, or moves too far from the dash, the lanyard will disconnect the clip from the switch, shutting off the engine.

To attach a lanyard, connect the clip to the emergency stop switch and the hook to a strong piece of clothing on the operator, such as a belt loop.

### IMPORTANT

**The engine will not start unless the clip is attached to the emergency stop switch.**

The emergency stop switch can only be effective when it is in good working condition.

Observe the following:

- **DO NOT** remove or modify an emergency stop switch and/or its lanyard.
- Keep the lanyard free from obstructions that could interfere with its operation.

Check the emergency stop switch once a month for proper operation. With the engine running, pull lanyard to pull the clip from the switch. If the engine does not stop, see your Tigé dealer for service immediately.

### HORN

The “HORN” button is a momentary switch. The horn will operate when the button is pressed and stop when the button is released.

### IGNITION KEY SWITCH

This key switch starts and stops the engine. A built-in protection system prevents the engine from starting in any gear and only in NEUTRAL. Refer to Shifter/Throttle Control in this section and refer to the engine owner’s manual for more information.

There is an accessory position on the ignition key switch. A terminal on the back of the switch is provided to control power to add-on accessories. Even though power to this terminal is protected by a 20-amp fuse, do not connect any accessory that draws more than 10 amps. Attaching an accessory to this terminal should only be done by a qualified technician.

### NOTICE

**DO NOT** connect an accessory drawing more than 10 amps to the key switch accessory terminal. A hazardous situation or damage to the electrical system can occur.



## CONTROLS



### WARNING

**Collision Hazard: An overspeeding engine, from loss of throttle control, can cause collision, resulting in death or serious injury. Make sure all control systems are regularly inspected and properly maintained.**

## SHIFTER / THROTTLE CONTROL

This single-lever control operates both the gearshift and throttle. The control can only be moved from the neutral position by lifting the safety ring under the throttle handle. Moving the control forward from the NEUTRAL position will advance the throttle FORWARD. Moving the control aft from the neutral position will advance the throttle REVERSE.

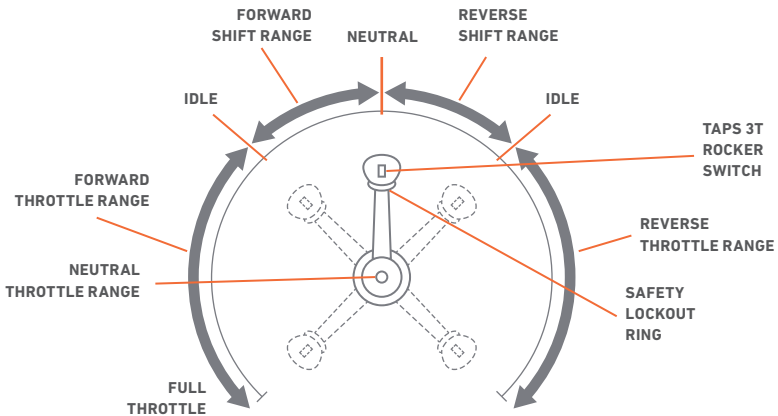

To “rev” the engine without engaging the transmission from NEUTRAL, push in the neutral throttle button and advance the throttle handle. To return to normal operation, return the throttle to the NEUTRAL position.



## IMPORTANT

The engine will only start in **NEUTRAL**. If the engine does turn over and the battery is charged, make sure the throttle handle is in **NEUTRAL** and try again.



### CAUTION

**DO NOT shift too quickly from FORWARD to REVERSE. Stay in NEUTRAL or idle position until the boat has lost most of its headway before completing the shift to REVERSE, or engine/transmission damage can occur.**

**Shifter/Throttle Control Handle:** Shifts from NEUTRAL to FORWARD or REVERSE and controls throttle position.

**Safety Lockout Ring (Shift Lockout):** Detent to prevent shifter from going into gear without driver action.

**Neutral Throttle Button:** Allows the throttle to be advanced without being engaged in gear.

**TAPS 2 Rocker Switch:** This controls the TAPS system. View the TAPS position by looking at the top and center of the Tigé CLEAR screen. TAPS can also be controlled through the Tigé CLEAR screen.

## SMART2 WHEEL CONTROLS

The Smart2 Wheel controls give you the ability to control many of the features of your boat. The volume can be controlled through the up, down and mute buttons, and songs can be selected using the forward and back track buttons. Pressing the camera icon will bring you to the backup camera view on your touch screen.

Using the left side of the steering wheel, you can activate and adjust your cruise control. Simply press the speedometer icon to enable cruise control, and use the  $\pm$  icons to adjust speed accordingly. The TAPS 3T plates can be controlled on the lower left side to adjust wave shape, and the bottom left “switch” button will transfer the surf wave to the other side of the boat.

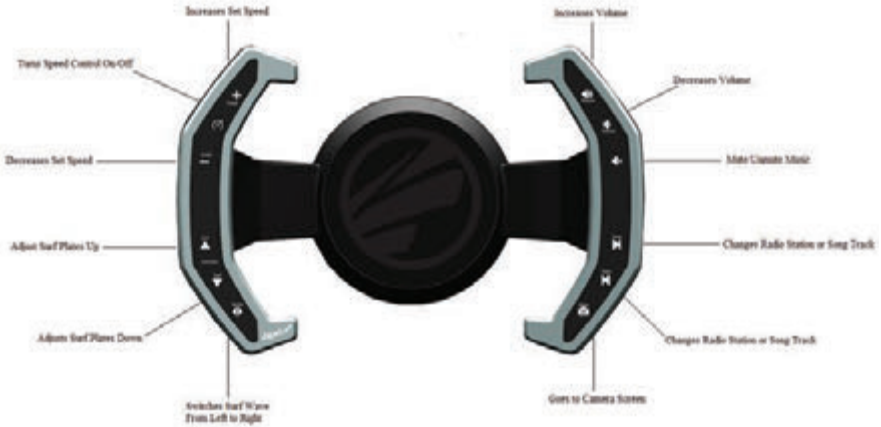

## GO SYSTEM EDIT SETTINGS

- To change the factory default GO System settings, click the gear icon next to the mute button.
- In the GO settings section push the edit button. Once you are here, you can edit Surf, Wake, Ski, and Home settings.
  - **Surf:** The user can change the speed, surf wave setting, taps setting, and ballast percentages
  - **Wake:** The user can change the speed, taps setting, and ballast percentages
  - **Ski:** The user can change the speed, taps setting, and ballast percentages
  - **Home:** The user can change the speed, taps setting and ballast percentages
- Once a setting has been changed you must press save before leaving the GO setting edit menu.
- To restore the factory default settings, go back to the edit page and select 'reset' and save.



## TAPS 3T

This controls the Surf System. View the TAPS 3T position by looking at the SURF screen on the Tigé CLEAR screen. TAPS 3T allows the rider to ride on either side of the wake by the flip of a switch. For more information refer to the Tigé CLEAR Manual.

## SURFLINK<sup>®</sup> REMOTE

This remote allows the rider to transfer waves by pressing the center button. When pressed the TAPS 3T system will raise one plate and lower the other plate to allow the rider to transfer waves. The UP and DOWN arrows allow the rider to adjust the TAPS 3T plates in order to create a more steep or less steep wave.

## TIGÉ ZERO OFF GPS CRUISE CONTROL PANEL

This panel controls the Tigé Zero Off GPS cruise control system.

## STEERING TILT LEVER

The steering tilt lever allows you to adjust the angle of the steering wheel.

DO NOT adjust when the boat is underway.

## STEREO REMOTE—OPTIONAL

This remote control allows the stereo to be controlled at the cockpit. For details on operation, refer to the stereo owner's manual.

## HEATER—OPTIONAL

This switch operates the fan to deliver heat to the cockpit and windshield. The vents have a diffuser which can be opened to allow more airflow toward the cockpit or closed to direct all the air to the windshield as a defogger. The diffuser also rotates to direct air to a desired direction.



## PORTS

### 12-VOLT PORTS—THROUGHOUT THE BOAT

These receptacles can be used to power or charge cellular phones, MP3 players, video cameras or other electronics which can be powered or charged from a 12 V DC system.

### IPOD™/MP3 PORT—OPTIONAL

This port provides a convenient means to connect your iPod or MP3 player to your boat's stereo system.

## GAUGES



**FUEL GAUGE:** Indicates the approximate amount of fuel in the tank via CANBUS. The ignition switch must be in the RUN position to activate the gauge.

**SPEEDOMETER:** Indicates forward speed of the boat in miles per hour (MPH) via CANBUS.



**ENGINE HOUR METER:** Keeps a running total of engine hours while engine is running via CANBUS. The hour meter is located on the compass page of our Tigé CLEAR screen.

Make sure the key is in the OFF position when the engine is not running. Accessory equipment (stereos, showers, etc.) should not be installed to operate when the key is in the ON position.

### IMPORTANT

**The hour meter will log time whenever the engine is running.**

**TACHOMETER:** Indicates engine speed in crankshaft revolutions per minute, or RPM via CANBUS.

**DIGITAL DEPTH FINDER/AIR/WATER TEMPERATURE DISPLAY:** Water depth, air, and water temperature are located on the second page of your Tigé CLEAR screen.

**ACCESSORY PORTS:** Your boat may be equipped with one or more accessory power ports for electronics. Ports may be a round 12VDC “cigarette lighter” style and/or 5VDC USB style. These ports are for power/charging only and are typically active when the battery switch is ON. USB ports cannot be used for uploading/downloading data or music and are typically limited to 2A draw. The ports are protected by a circuit breaker or may have an inline fuse.

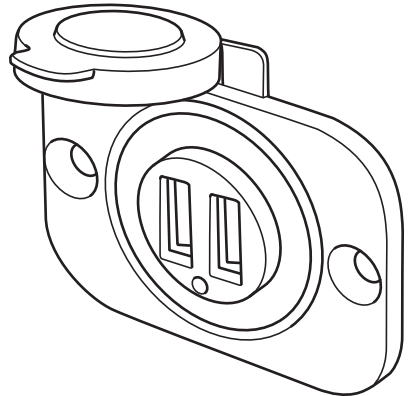

## SETTING THE ZERO OFF GPS CRUISE CONTROL DISPLAY UNITS

1. Enter the Settings menu by using the gear-shaped icon at the top of the touch screen.
2. Select the preferred units from the menu on the left-hand side. Use the “close” button to return to the home screen.

**TAPS GAUGE:** Indicates the position of the TAPS plate located on the top of the Tigé CLEAR home screen.

### NOTICE

**DO NOT** connect an accessory drawing more than the breaker's amperage capacity. A hazardous situation or damage to the electrical system can occur.





## FUSES

Fuses protect the circuit by limiting the amount of current which can flow. If a fuse should “blow,” it usually indicates a problem. See your Tigé dealer.

Use only an identical replacement when replacing the fuse.

## COCKPIT AND EXTERIOR

### TIGÉ/ATX KEYLESS IGNITION OPERATION

The Tigé/ATX keyless control is an electronic lock requiring a predetermined numeric code (password) in order to start and stop the engine.



**To turn on the display:** Press the power button. LED should change from off to yellow.

**To start the engine:** Enter your passcode. LED will change from yellow to green. Press and hold the start button to start the engine.

**To stop the engine:** Press stop or press the power button to turn off the engine and the display.

**To change your passcode:** Turn the power on and enter the current passcode. The LED will turn green. Press and hold the 1 and 5 keys for about 5 seconds. The LED will begin to flash yellow. Enter your new 4 digit passcode and then press stop. The LED will flash green, and then continue to flash yellow. Enter your new passcode again to confirm it. Press stop again. The password is now changed and the LED will turn back to green.

#### LED Status Indicator

**Yellow:** Screen is on. No passcode has been entered.



**Flashing Yellow:** Passcode is being changed.

**Green:** Passcode has been entered correctly. Ready to start engine.

**Flashing Green:** Engine is attempting to start.

**Blue:** Engine is assumed\* to be running.

**Flashing Red:** Incorrect passcode was entered.

\* Because the keypad does not communicate on the CAN network, there is no way for it to read if the engine is actually running or not. If the engine does not start on the first attempt, press stop to return to the green LED state, and then try to start the engine again.

## BATTERY DISCONNECT SWITCH

The battery disconnect switch allows you to isolate all power to the boat. This switch provides positive disconnection of the battery to protect against tampering, electrical fire hazards and battery rundown. Rotate the switch to the OFF position when the boat is not in use.

## SWIM PLATFORM

 **DANGER** *Exposure to carbon monoxide or a spinning propeller will cause death or serious injury. DO NOT use the swim/boarding platform for any other purpose than boarding the craft or preparation for entering the water, and DO NOT use the swim/boarding platform when the engine is running.*

The swim platform is a convenient feature to enjoy water sports and helps provide safer boating. The swim platform is required for exiting and entering your boat and protects you from underwater components of your boat.

There are very serious safety concerns regarding the use of the platform and safety labels are used to convey safety around the platform. For more information, *review Safety in Section 2.*

## BOW FEATURES OF YOUR TIGÉ

The open bow section of your boat may have cushions which can be raised to access storage. Storage areas are for storage only and should not be occupied by passengers. These areas do not provide adequate ventilation and can accumulate CO.



Store the cushion in the trunk or under the observer's seat when it is not in use or before getting underway.

The Lexan<sup>®</sup> Walk-thru Windscreen can be installed by sliding it into position and closing the windshield. Keep the windscreen in its protective boot and stow when it is not in use. The windscreen will not float.

## WALK-THRU WINDSHIELD OPENING / LATCHING

The two latches on the inside starboard side of the walk-thru windshield must be latched when the boat is underway or trailered. Rotate both of the window locks to secure or unlock the window.



### CAUTION

*Glass door must be closed and secured with both locks when the boat is underway.*

## COCKPIT SEATING



### WARNING

*Drowning or Loss of Control Hazard: Ejection or sudden loss of control can cause death or serious injury from improper use of seating. DO NOT stand while driving above the engine idle speeds and make sure cockpit seat is in the locked/secured position and all passengers are seated when the boat is underway.*

## EIDB DUAL-BATTERY SYSTEM—IF EQUIPPED

The EIDB dual-battery system protects your starting battery from discharging when high-amperage accessories, like a high-output stereo system, are being used. The system allows the amperage to be drawn from the accessory battery only, without drawing from the starter battery. When the engine is restarted, both batteries will be charged, but will direct the charge to the weaker battery first.

## BATTERIES

The standard battery is a heavy-duty, marine-grade 12 V battery. This battery primarily serves as the cranking battery and can operate standard equipment. A cranking battery is not designed to fully discharge like a deep-cycle battery, which can be fully discharged more often. It is not recommended to fully discharge the cranking battery. Do not have the battery switch on "Combine" while operating the boat. The battery switch should only be on "Combine" in case of an emergency.



The EIDB dual-battery system includes a cranking battery and a deep-cycle battery. A deep-cycle battery is designed specifically for providing constant power to high-output stereo systems for extended periods of time.

## ENGINE COMPARTMENT COVER

The engine compartment cover is a machinery guard and must be in place and closed whenever the engine is running. DO NOT operate your boat without the cover in place or closed unless you are performing a check or maintenance.

 **WARNING** *Moving Parts Hazard: Contact with moving parts can entangle, cut and cause death or serious injury. Never get close enough to make contact with any running machinery's moving parts, i.e. engine or propeller. Contact can result in loss of body parts, strangulation, burns and/or severe loss of blood, resulting in serious injury or death.*

## V-DRIVE MODELS

### 20RZX / 22RZX / 24RZX / 25ZX / 23ZX / 21ZX / Z5 / Z3 / Z1

To open the engine cover, first open both rear storage compartments by lifting the latch. Next pull the reversible seat out away from the back of the boat. Grab the handles located at the bottom corners of the engine hatch and pull up. A gas shock will help raise the cover. To close the cover, grab the two handles and pull the engine cover down. Push the reversible seat back in the locked position. Close the storage compartments. Keep hands, fingers or any other obstructions clear when closing.

## POWERED CAPTAIN'S CHAIR

If your boat is equipped with a powered captain's chair, it can be raised and lowered using the controls on the display. Touch the chair icon, and then press and hold up or down until the seat is in the desired position. The levers on the side control fore/aft movement and swivel function.

## OBSERVER'S SEAT

Lift up on the bottom of the observer's seat to access storage under the glove box. Leave the seat up periodically to help keep the storage area dry.



## FLIP-UP OBSERVER'S SEAT—IF EQUIPPED

There are two positions for this seat. To bring the seat up to its first position grab the handle and pull the seat up until you hear the pin lock into place. To bring the seat to a more upright position, pull the locking pin out and continue to pull the seat up until you hear the pin lock in again. Make sure the pin has locked before sitting on the seat. To lower the seat back down, pull the pin out and push the seat back down. Depending on what position the seat was in, you might have to pull the pin out two times before the seat is back in the lowered position.

## HEATED SEATS—OPTIONAL

The heated seats are located in the driver seat and the observer seat. To turn on the heated seats, press the “heated seats” button on the screen in the switches section. To turn them off, press the button again or press the on/off button for the screen.

NOTE — The heated seats have a timer before they turn off on their own. After one hour the heated seats will turn off.

## STORAGE HATCH

To open the storage hatch, lift the latch and turn counterclockwise. A gas shock will help raise the hatch. To close and latch, push down on and allow the hatch to close firmly. Keep hands, fingers or any other obstructions clear of the hatch when closing.

## RETRACTABLE PYLON

Some models are equipped with a retractable pylon. This pylon is extended by lifting the latch and pulling the pylon upward. To lock the pylon, turn it counter clockwise until it stops. To put the pylon away, turn it clockwise and then push it back down.



## WATER SPORTS TOW PYLON SAFETY

 **WARNING** *Improper use of the tower may overstress the tower, imbalance the boat or allow the tow rope to contact passengers, potentially causing personal injury or death.*

### DO NOT

- *Tow more than one (1) person at a time*
- *Tow parasails, kites, inflatable towables or other watercraft*
- *Allow passengers to sit behind rope attachment point when tower is in use*
- *Fold or remove tower without assistance*
- *Use the tower if bolts are loose or missing*
- *Use tower if tower shows any signs of stress*

### DO

- *Before each use check that all bolts are tight and in place*
- *Before each use check that tower has no signs of stress*
- *Watch for low bridges and hanging obstacles*
- *Watch for electrical lines that may come in contact with the tower*
- *Make certain your vision and line of sight are unobstructed*
- *Ensure proper use of tower to avoid overstressing tower or unbalancing boat*
- *Make certain tow rope does not contact any passengers.*

 **WARNING** *Check the tightness of fixtures before towing. Do not tow more than one (1) person or 300 lbs. Always use the correct tow rope. Failure to do so can cause serious injury or death. Read the owner's manual before engaging in watersports.*

Improper use of the tow pylon can overstress the pylon, imbalance the boat or allow the tow rope to come into contact with passengers.

- **DO NOT** use the tow pylon for towing parasails, kites or other watercraft.
- **DO NOT** tow more than one person at a time or exceed a load of 300 lbs (136 kg).
- **DO NOT** allow passengers to sit behind the tow pylon when it is in use.
- Check that the tow pylon is secure before every use.

The tow pylon is designed for towing a wakeboard or a ski device only.

Misuse of the tow-point can cause death or serious injury. The pylon was designed for water sports only. **DO NOT** use the parasailing, kite flying, towing other watercraft and/or using pylon extensions. **DO NOT** sit behind (aft) the pylon when tow pylon is in use.



The water sports tow pylon is manufactured from high-strength aluminum alloy, engineered for durability. The tow pylon is rated to tow one person and not to exceed the weight of 300 lbs (136 kg). If the load limit is exceeded or becomes loose when towing, the tow pylon could separate from the boat. If the pylon separates from the boat, it could become a missile hazard because of its mass and strike someone, causing death or serious injury.

Make sure the tow pylon is secured to the boat before each use and the tower is tight. Tow pylons can loosen over time, and must be inspected and tightened before every use. If the tow pylon is loose when towing, it could separate from the boat.

Although pylon extensions and barefoot booms have become popular additions to many tournament inboards, most boat manufacturers oppose the use of any pylon extension, whether up or to the side of any of their products. The use of pylon extensions can alter the handling characteristics of the boat, possibly resulting in dangerous instability, which can lead to loss of control or a situation which can cause death or serious injury to the boat driver, passengers, skiers and anyone else who might be in the vicinity.

## ALPHA E3 TOWER

Before lowering the tower, make sure the bimini is moved to the upright position.

This is done by pulling the pin on each side of the bimini mounting bracket to the tower. Push the bimini up 90 degrees and lock it back in place. The bimini should now be pointing straight up to the sky. Now that the bimini is in the correct position you may now proceed to lower the tower.

To lower this tower you use a switch that is located on the bottom side of the tower, directly below the tow point.

1. When lowering press the switch down and continue to hold the switch until the tower has stopped moving.
2. Once the tower has stopped lowering you may release the switch.
3. To raise the tower up, press the switch up and continue to hold the switch down until the tower connects back with the base of the tower.
4. Once it connects you will hear a clicking sound; that is the tower telling you it has been connected and you can stop pressing the switch.
5. Once the tower is raised, return the bimini to the original position by pulling the locking pins on each side of the bimini mounting bracket and laying the bimini forward.
6. Make sure the pins are locked once the bimini has reached this position.



If the switch is not working:

1. First check to see if the circuit breaker has been engaged. This is located next to the switch at the center of the tower in a rubber boot. If the pin is out press it back in.
2. If the switch is still not operating you will have to manually lower the tower. In order to do so you will need two 6 mm Allen wrenches and one other person.
3. At the rear base of the tower there is a small piece of chrome. You must remove this in order to have access to the actuator. Use the Allen wrench to remove the small screw that covers the access to the actuator.
4. Once the screw is removed, you and the other person must turn both actuators using the Allen wrenches simultaneously until the tower is in the lowered position.

When lowering or raising the tower make sure no persons are in the boat. Keep all hands, fingers, and other objects away from the base of the tower when lowering and raising to avoid serious injury to oneself or the tower. Do not apply extra weight or hang from the tower when lowering or raising.

**WARNING**

*Failure to obey the following cautions could result in death or serious injury.*

**DO**

- *Before each use check to be certain all bolts are tight and in place.*
- *Before each use check to be certain tower has no signs of stress.*
- *Watch for low bridges and hanging obstacles.*
- *Watch for electrical lines that may come in contact with the tower.*
- *Make certain your vision and line of sight are unobstructed.*
- *Ensure proper use of tower to avoid overstressing tower or unbalancing boat.*
- *Make sure tow rope does not contact any passengers.*

**DO NOT**

- *Tow more than one (1) person at a time.*
- *Tow parasails, kites, inflatable towables or other watercraft.*
- *Jump from, dive off, climb on, ride, hang onto or sit on tower at any time.*
- *Allow passengers to sit behind rope attachment point when tower is in use.*
- *Use tower if bolts are loose or missing.*
- *Use tower if tower shows any signs of stress.*





## ALPHA E3+ WITH SOLIDSHADE

### CENTER HOUSING SAFETY LATCH

Before lowering the tower, you must disengage the safety latch located in the front of the center housing actuator, which is located at the top center of the tower.

- To release the latch, push the release button located at the top of the latch and pull down.
- The latch will now hang freely, and you can lower the tower.
- To close the safety latch, push the latch up and make sure it locks. The latch should be tight and unable to move.

#### **NOTICE**

*If you do not release the safety latch before lowering the tower, you will destroy the latch and/or the actuator inside the center housing. Damaging either item will not be covered under the Tigé 5-Year Warranty.*

### LOWERING TOWER



#### **CAUTION**

*Before lowering the tower, ensure the area around the tower is clear.*

- Before lowering the tower, you must disengage the safety latch. (See instructions above).
- Once the safety latch is disengaged, locate the switch in the portside rear pocket (left/passenger side).
- Locate the rectangular rocker switch that goes up and down as well as a circular safety push button.
- Press the circular safety button and rocker switch down at the same time.
- As the tower begins to lower, the SolidShade frame will begin to move with it simultaneously. Once the tower is all the way down, continue to hold the switch as the SolidShade frame continues to move into its final position. Once the frame has stopped moving, release the switch.

#### **NOTICE**

*To ensure that all three actuators stay in sync, DO NOT release the rocker switch until the tower and SolidShade frame are all the way down. If you release the rocker switch and stop the tower in motion before going all the way down, you must bring the tower back up and start over so that all three actuators are back in sync.*



## RAISING TOWER

 **CAUTION** *Before raising the tower, ensure the area around the tower is clear.*

- To raise the tower, you must push the circular safety button and push up on the rocker switch at the same time. Once the tower starts to go up, the tower and SolidShade frame will move together simultaneously.
- Continue to hold the rocker switch up until the tower is in the locked upright position, and the SolidShade's frame is in the deployed position (the center housing unit will be completely closed). Release the rocker switch.
- Once tower is in the upright position, you must close the safety latch located at the top center housing. To do this, push the latch up and make sure it locks. The latch should be tight and unable to move.

## TOWING/TRAILERING WITH SOLIDSHADE

### Tower Up

- When trailering your boat with the tower up, the SolidShade canvas must be removed from the frame. You must do this whether your boat is covered or uncovered with a mooring cover.

### Tower Down

- When trailering your boat with the tower down, with no mooring cover, you must remove the SolidShade canvas and use the SolidShade frame support pole.

### Tower Down with Protect-All Cover

- When trailering your boat with the tower down and using the Outer Armor Protect-All cover (over the tower), the canvas may remain on the SolidShade frame, and you must use the SolidShade frame support pole.



## SOLIDSHADE CANVAS

### Installing the Canvas

- To install the SolidShade canvas, start by locating the tag on the inside of the canvas that says 'front.'
- Once you have located the tag, place the canvas over the frame starting from the front and wrap the canvas over the sides of the SolidShade frame.
- Now, wrap the rest of the canvas over the back of the frame.
- Once the canvas covers the frame entirely, use the two ratchet straps on the back underside of the canvas to tighten it down.
- Use the velcro flaps to secure the ratchets.

### Removing the Canvas

- Undo the velcro straps and loosen the two ratchet straps.
- Once the ratchets are loose, you can remove the canvas, starting from the back of the SolidShade frame and working towards the front.

## INSTALLING PLUG AND PLAY BOARD BAGS

- To install the Plug and Play Board Bags, undo four straps on top of the SolidShade canvas, by releasing eight buckles.
- Once the straps are removed, place the board bag on top of the SolidShade canvas with the Tige logo towards the front of the boat.
- Connect four buckles per board bag to the SolidShade canvas.
- Once the board bags are securely buckled to the canvas, locate the velcro at the front of each board bag and attach it to the front underside of the canvas.



## ALPHA E3 BIMINI

### To deploy the bimini:

1. Unbuckle the two straps securing the bimini boot to the tower.
2. Slide the bimini towards the bow of the boat until the hinge point reaches the black plastic guides on the bracket.
3. Unzip the bimini boot, and store it somewhere dry.
4. Unroll the bimini, then flip the upper half of the frame 180 degrees so it extends behind the tower.

NOTE — The bimini has an opening for the tow point and anchor light to pass through. Make sure the canvas is not on top of the light.

5. Attach the support pole on one side to the mount on the tower.
  - a. Ensure the mount is in the unlocked position.
  - b. Slide the ball of the support pole into the opening of the mount.
  - c. Twist the D-ring on the tower mount 180 degrees to lock the support pole into place.
6. Repeat for the other side.
7. Tighten the canvas by pulling the four Velcro tabs around the frame and attaching them to the Velcro patches on the bottom side of the bimini canvas.

### To stow the bimini:

1. Disconnect the Velcro tabs.
2. Unlock and remove the support poles on both sides.
3. Clip the support poles back onto the frame to prevent rattling and damage.
4. Flip the back half of the bimini over to the front half.
5. Roll the bimini around the frame so that it will fit neatly into the boot.
6. Zip the boot onto the bimini with the Tigé logo upright so that the straps will be properly oriented.
7. Slide the bimini back until it reaches the black plastic stoppers on the frame.
8. Secure the bimini to the tower using the two straps on the boot.

### To prepare your bimini to lower the tower:

1. Remove the boot straps.
2. Pull back the spring pins on each bracket. These can be locked open by twisting the ring 90 degrees.
3. Rotate the bimini upward 90 degrees, then re-engage the pins into the holes on the bracket.
4. Ensure both pins are seated, then lower the tower.

**To raise the tower:**

1. Lift the tower while supporting the bimini with a hand.
2. Pull back each spring pin.
3. Rotate the bimini back down. Keep hands away from the rotating bracket.
4. Once the bimini is back down, re-engage each spring pin. Ensure the pins are seated properly.
5. Re-secure the boot straps before driving or towing.

**TRAILERING OR TOWING WITH A BIMINI:**

1. When towing or trailering the E3 bimini must be in the stowed position. The bimini cannot be deployed when towing or trailering.

**COVE COVER FOR E3 TOWER—IF EQUIPPED**

To install your Cove Cover:

1. Attach the end with three straps to the tower. The center strap loops around the tow pylon, and the outer straps loop around the L-shaped arm of the bimini bracket.
2. Insert the poles into the receivers on the gunwale.
3. Attach the D-Ring in each aft corner around the notch at the top of the pole.
4. Loosen or tighten the buckles attached to the tower as necessary to achieve the correct fit. The poles will be bent when the cover is installed to prevent sagging.

**NOTICE**

*The cove cover is not designed to be deployed while underway. Using the cove cover while underway can cause damage to the bimini, the poles, the gelcoat near the deck mounts, or the cover itself.*



## COVE COVER FOR E3+ WITH SOLIDSHADE—IF EQUIPPED

To install your Cove Cover:

1. Attached the end with the three straps to the tower. The center strap loops around the tow pylon. The outer straps wrap around the SolidShade frame. See pictures for reference.
2. Insert the poles into the receivers on the gunwale.
3. Attach the D-ring in each aft corner around the notch at the top of the pole.
4. Loosen or tighten the buckles attached to the tower as necessary to achieve the correct fit. The poles will be bent when the cover is installed to prevent sagging.

### **NOTICE**

*The cove cover is not designed to be deployed while underway. Using the cove cover while underway can cause damage to the bimini, the poles, the guncoat near the deck mounts, or the cover itself.*

## BACKUP CAMERA—IF EQUIPPED

This camera allows the driver to see a rider in the water without having to turn around and look back at them. The camera video will be seen on the Tigé CLEAR screen. To access the camera feed:

1. Select VIDEO on the home screen. This will bring you to the camera feed.
2. If there is no video, try selecting the other input located on the left side of the screen.
3. To leave the video screen press the bottom left button to bring you back to the home screen.



## PULL-OUT CLEATS

The pull-out cleats allow the cleats to be stowed inside the boat's exterior when they are not in use. Pull the cleats out when they are to be used and return them when they are not in use. **DO NOT** use the cleats for towing or tying as an anchoring point.

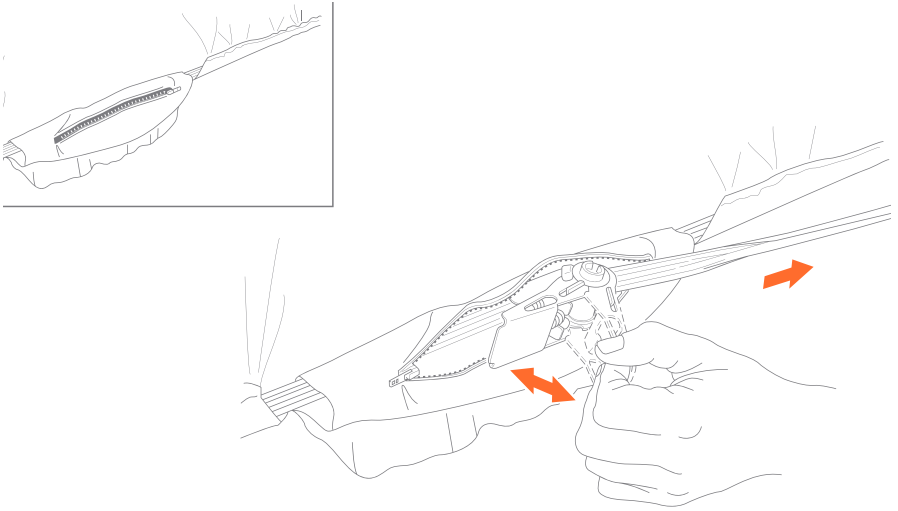

## MOORING BOAT COVER (TOWER UP) - IF EQUIPPED

The Mooring cover is designed to protect your boat during trailering and short-term storage.

1. Start by installing the cover from the bow of the boat and unfold the cover as you move it towards the back of the boat.
2. While unfolding your cover and working towards the back of the boat, pause at the tower and locate where the cover wraps around the tower base. Velcro one side to the other and buckle the strap together.
3. Before moving on from the tower, hang the tension strap to the center tow point located at the top of the tower.
4. Continue to pull the cover to the back of the boat and pull it over the back.
5. There are straps on the back that loop around the rear lift eyes.
6. Use the ratchets to tighten the cover.



## ALPHA E3 OUTER ARMOR COVER (OVER TOWER)—IF EQUIPPED

When putting the cover over the tower follow these steps:

1. Before lowering the tower, open the windshield center hatch.
2. Locate the locking pin on the bimini brackets and release them in order to push the bimini straight up in the air, then reengage the locking pins.
3. Lower the tower using the switch located on the bottom side of the tower, directly beneath the tow point.
4. Make sure the board racks are rotated inside the boat.
5. Once the tower is lowered all the way down, use the bimini support pole.
6. The bimini support pole should be placed in the walk-thru; use the Velcro<sup>®</sup> strap to secure the bimini to the pole.
7. Now that the tower is down and the bimini is supported, put the cover on.
8. Cover the boat by starting at the bow.
9. Use the other support pole in the center of the boat and attach the support strap to the top of the tower.
10. Use the ratchets on the cover located at the rear of the boat to tighten the cover.







## ALPHA E3+ WITH SOLIDSHADE OUTER-ARMOR COVER (OVER TOWER COVER)

If your boat is equipped, follow these steps:

1. Before lowering the tower, open the windshield center hatch.
2. Release the safety latch on the center housing of the tower.
3. Lower the tower by using the switch in the portside rear pocket.
4. Make sure the board racks are rotated towards the inside of the boat.
5. Once the tower is completely collapsed, locate the SolidShade support pole and attach it to the SolidShade frame in the walkthrough, between the windshield.
6. Once the tower is down and the SolidShade frame is supported, put the cover on.
7. Cover the boat by starting at the bow (front of the boat); working your way towards the transom (back of the boat.)
8. Use the ratchet on the cover to tighten the cover. The ratchet will be located in a zipper pocket at the rear of the boat.





## PLUG AND PLAY BALLAST

The Plug and Play ballast may exceed Coast Guard capacity depending on persons and gear. Please refer to the Coast Guard maximum capacity sticker for safety regulations.

All models come with Plug and Play ballast and depending on model can be connected into the system differently. Please see installation instructions for your model below.

### 20RZX / 21ZX / 23ZX / 25ZX

The Plug and Play ballast for these models has bags with four ports on the bag.

1. Place the bag in the locker so that the two fittings labeled Fill and Vent are on the top and the two fittings on the side towards the bottom that say drain are towards the outside of the boat.
2. Connect the hose extension to the drain port that is towards the front of the boat.
3. You will see two hoses with caps on them, one in the front bulkhead and one in the rear bulkhead in the bottom corner. Remove both caps. The bottom rear hose goes to the other drain port. The front bulkhead hose goes to the fill port on top of the bag.
4. You will see another long hose that has two quick-connect fittings on that comes from the rear bulkhead. Disconnect the quick-connects so that the shorter hose goes to the top of the bag and connects to the vent port and now connect the longer hose to the front drain port.
5. If you decide to remove the Plug and Play bags remember to put the caps bag on the two hoses and reconnect the hose coming through the liner to the vent hose.

## ZX/RZX REVERSIBLE SEAT AND TABLE

To set up the reversible seat:

1. Lift from the center grab handle and rotate the seat around towards the front of the boat into the reverse viewing position. The backrest will remain locked.
2. Push on the lock tab on the left side at the hinge point to unlock the backrest and lift the backrest up until it stops.



To deploy the table:

1. Deploy the reversible seat first.
2. Turn the handle on the back of the leanback of the reversible seat and rotate the leanback towards the back of the boat so that the table is level with the bench seat.
3. Release the handle and the table will lock in place.

To return the table to the stowed position:

1. Turn the handle, and rotate the table back towards the front of the boat.
2. Release the handle and the table will lock back in place as the leanback.

To return the reversible seat to the original position:

1. Push the backrest down until it clicks into the locking position.
2. Rotate the seat back around towards the back of the boat until it rests in the forward viewing position.

## Z SERIES REVERSIBLE BENCH

**To deploy the reversible seat:**

1. Grab the cushion frame on the aft side of the bench and lift up. The bench will pivot around the front sliding pegs.
2. Flip the bench 180 degrees. The pins will pass through the openings on the top side of the sliding tracks.
3. Lift up on the aft side of the cushion so the aft pins lift out of the safety notch.
4. Slide the bench towards the bow until the forward pegs fall into the notch at the end of the sliding track.
5. Ensure the bench is secured from sliding before stepping or sitting on the cushion.

The bench uses a backrest that is stored at the center of the aft wall of the cockpit. Simply lift up on the backrest to remove it from the storage receivers, and then insert the backrest into the bench receivers.

**To stow the bench:**

1. Remove the backrest from the bench and insert it into the storage receivers on the cockpit wall.
2. Lift up on the forward side of the bench frame, then slide the bench back until it reaches the aft safety notch.
3. Lift the bench frame and flip it 180 degrees back into the stowed position.
4. Ensure the bench is secured from sliding before stepping or sitting on the cushion.



SECTION  
**7**

# FEATURES

This Page Intentionally Left Blank

# Section 8

## OPERATING THE BOAT

There are many things to consider when planning a safe and enjoyable boating trip. This section describes the basics on fueling, starting, shifting/running, steering, docking and stopping your boat. This section also includes a safety preflight checklist, boarding guidelines, boat loading information and other important topics on handling your boat. Knowing and understanding all of these fundamentals will give you confidence in using your boat.

Read and understand the contents of this section before casting off. Remember, if you have a problem during your outing, you cannot get out and fix it, or walk to safety or for help. You are responsible for the safety of all passengers, the boat and any damage your boat or its wake may cause. Always keep passengers from blocking your view so that you do not run into other boats, swimmers, water skiers, personal water vehicles or aids to navigation.

Before operating the boat, review *Safety in Section 2*.

### BEFORE LAUNCH

Check and tighten all hardware including pylons, towers, speakers and other accessories.

#### **Energize Electrical System. Energize system by:**

- Turning on the Battery Disconnect Switch located in the glove box (for RZX3, RZX2, ZX5, and ZX1, the switch is located in the glove box).
- Check fuel level. If possible, fill tank at a land-based fueling station. Marina gas sometimes contains water and is usually more expensive. Highest octane gas available is recommended.
- Make sure the Saltwater Flush Kit shut-off valve (if equipped), and/or seacock on water pickup (seacock applies to all models sold in Canada), is open (handle in-line [OPEN] with hose, not perpendicular [CLOSED]).
- Check engine oil level.
- Check transmission fluid level.
- Check battery charge.
- Check and operate the blower.
- Check that bilge drain plug is installed properly.
- Check the propeller, strut and rudder for damage.
- Check the weather report, wind and water conditions.
- Lift engine compartment cover to check for evidence of gasoline fumes.



- Check that the required safety equipment is on board.
- Check that the fire extinguisher is fully charged.
- Check that all required maintenance has been performed.
- Check bilge pump operation and make sure bilge is free of debris.
- Check steering and rudder movement.
- Make sure adequate number of PFDs and all other Coast Guard-required items are onboard and accessible.

## SAFETY EQUIPMENT

Federal and local laws require certain safety equipment to be onboard at all times. In addition, responsible boaters carry other equipment in case of emergency. Check with local boating authorities for any additional requirements over and above federal requirements.

Refer to Section 2, SAFETY, Required Safety Equipment.

## FLOAT PLAN

Complete a float plan before departure and leave it with a reliable person who is aware of your intentions while on the water. In case of emergency or if you do not return as planned, this information can be helpful to the USCG or others in rescuing or contacting you. There are several float plan apps that make it easy to fill out and email the plan. For more information on float plans or to download a float plan form, go to:

<http://www.floatplancentral.cgaux.org>

## PREFLIGHT CHECKLIST

The following checks are essential to safe boating and must be performed before starting the engine. Get in the habit of performing these checks in the same order each time so that it becomes routine.

**DO NOT** launch the boat if any problem is found during the safety check. A problem could lead to an accident during the outing, causing severe injury or death. Have any problem attended to immediately; see your dealer.



## BEFORE TOWING

- Check trailer tire pressure and tire wheels.
- Ensure trailer is securely connected to tow vehicle. Check safety wires and pin. Check bow hook to ensure boat is hooked on trailer.

## PRE-OPERATION

- Check that no fuel, oil or water is leaking or has leaked into the bilge compartment.
- Check all hoses and connections for leakage and damage.
- Check the engine cooling water intake pick-up for blockage.
- Check that battery terminals are clean and tight.
- Check electrical circuits (lights, pumps, horn, etc.) for proper operation.
- Check that shifter/throttle control handle is in NEUTRAL.
- Check that the steering system operates properly.

## CHECKS DURING OPERATION

- Monitor gauges frequently for signs of abnormal behavior.
- Check that controls operate smoothly.
- Check for excessive vibration.

## BOARDING

When boarding the boat, always step in. Do not jump. Avoid stepping on fiberglass or other potentially slippery surfaces. Board one person at a time.

**DO NOT** board the boat while carrying gear. Set gear on the dock, board the boat and then pick up the gear.

Always face the boat when boarding/reboarding using a ladder.

When boarding once in the water, swim towards the back of the boat to the swim platform. Grab ahold of the grab handle located above the swim platform and pull your body up onto the swim platform. Step up from the swim platform onto the boat. Avoid stepping on the fiberglass or other potentially slippery surfaces.



## BOAT LOADING

The performance of your boat is dependent on load weight and distribution.

Passengers should board one at a time and should distribute themselves to maintain trim. Remember to distribute weight from right to left, and also from front to back.

All passengers should be carefully seated and not be riding on the deck, gunwale or rear sun deck while underway. Passengers riding in the bow should exercise extreme caution. Do not overload the open bow area. Never seat more than three people in the open bow area (See seating chart on page 10). Refer to the Capacity Label and Seating Chart for number of people allowed in the bow area. Children under 11 years of age should not use the open bow area unless accompanied by an adult. During rough water operation, passengers in the bow should move to the aft passenger seats.

- **DO NOT** allow your passengers to ride with their feet dangling over the side; floating debris can cause serious injury.
- Avoid excess weight in the bow or stern.
- Securely stow all extra gear in stowage areas to prevent load shifting.

Do not stow gear on top of safety equipment; safety equipment must be quickly accessible.

In adverse weather, reduce the load in the boat. People/load capacity ratings are based upon normal boating conditions.

## FUELING

### FUEL MANAGEMENT

Use the “one-third” rule for fuel management. Use one-third of the fuel to reach your destination, one-third to return and one-third as reserve fuel.

### FUEL SUPPLIERS

Refuel only at approved suppliers such as marina fuel docks or automotive fuel service stations. Approved suppliers have safeguards in place to lessen the likelihood of static discharge. Use only containers and funnels approved for use with the fuel type. See the *Before Refueling* section of this manual for additional information.





## STATIC ELECTRICITY AND THE FUEL SYSTEM

The boat's built-in fuel tank has a bonding system that protects it from creating and discharging static electricity. The boat must be in contact with the water or on its trailer when refueling to complete the bonding system.

If the bonding system is not complete, an electrostatic spark may occur.

**⚠️ WARNING** *Fire/Explosion Hazard: An electrostatic spark can ignite fuel vapors, causing a fire and/or explosion.*

Use extreme caution when filling the fuel system. In addition:

- Remove portable fuel tanks from the boat and place them on the ground to fill. The fuel tank must be properly grounded before refueling. If keeping portable tanks on board, store them only in a ventilated compartment. Never store them in an engine compartment or near heat/flame-producing accessories.
- Do not refuel a built-in fuel tank if the boat is suspended from a sling or another type of boat lift system. Suspending the boat from the water interrupts its bonding system. Using a portable fuel tank to refuel the boat while it is suspended may cause an electrostatic spark.

## FUEL (GASOLINE)

Fuel for marine gasoline-only engines must be carefully selected to avoid fines and possible catastrophic engine damage not covered under warranty. It is illegal for any person to tamper with emissions control devices such as the fuel system, and it is also illegal for any person to mis-fuel a marine gasoline-only engine with a blend of more than 10% ethanol.



While it is always preferable to use fuel that does not contain ethanol (usually labeled as “marine” or “recreational”), most marine engines are designed to tolerate E10 (10% maximum ethanol) fuel as long as the fuel meets the engine manufacturer’s octane requirements. When using fuel containing ethanol, buy fuel in smaller quantities that will be consumed during the boating session with a 10% reserve. Fuel degrades quickly and the engine operates better on fresh fuel. Use marine fuel stabilizer to treat and reduce degradation of any remaining fuel.





Fuels that contain bio-isobutanol at any percentage are safe to use in marine products and have none of the limitations of ethanol biofuel additives.

Do not use octane boosters or other fuel additives except marine certified fuel stabilizer. Purchase fuel from a quality supplier selling high volumes to ensure the fuel is fresh. For more information go to: [www.toptiergas.com/licensed-brands/](http://www.toptiergas.com/licensed-brands/)

**NOTICE**

*Fuels that are blended to contain more than 10% ethanol may damage the engine, oil system or fuel system and should not be used in marine engines. Fuels that contain more than 10% ethanol can corrode metal parts, deteriorate rubber and plastic, or weaken gaskets. Damages caused by the use of fuels that contain more than 10% ethanol or fuels that do not meet engine manufacturer octane requirements are not covered by your warranty.*

**Gasoline Fuel in the U.S. Market**

The majority of recreational boats are trailerable and often fueled at automobile gasoline filling stations. In the U.S. market, there are ever-increasing percentages of ethanol blended with gasoline with the most common being 10%. Since there is no standard for labeling gas pumps, it can be confusing to select the proper blend – **LOOK BEFORE YOU PUMP!**

Ethanol blends of more than 10% are tempting to use in your boat because they are cheaper. Ethanol blends of more than 10% are **NOT** meant for ANY outdoor power equipment and their illegal use will not only deteriorate rubber and plastic, causing an environmental hazard, but will cause permanent **DAMAGE** to the engine that is not covered by the Warranty – **DO NOT BUY GAS BY PRICE!**

	CONTAINS NO ETHANOL	UP TO 10% ETHANOL	UP TO 15% ETHANOL	UP TO 30% ETHANOL	UP TO 50% ETHANOL	UP TO 85% ETHANOL
OK for Boat Engines	Yes	Yes**	No	No	No	No
OK for Long-Term* Storage	Yes*	No	No	No	No	No
Covered by Engine Warranty	Yes	Yes	No	No	No	No
Illegal to Use in Boat Engines	No	No	Yes	Yes	Yes	Yes
Price	Most Expensive	About 5% less	About 10% less	About 20% less	About 30% less	Least Expensive

\* 3 – 6 months with marine-grade fuel stabilizer *added immediately*

\*\* Not more than one month with marine-grade fuel stabilizer *added immediately*



## BEFORE REFUELING



### WARNING

**Fire/Explosion Hazard: Gasoline is extremely flammable and highly explosive under certain conditions. Be sure to check the fuel hoses and connectors for leaking and deterioration before fueling and on a monthly basis.**

- Refuel the tanks only in a well-lighted area.
- Know where the fire extinguishers are.
- Stop all engines, motors, blowers and appliances before refueling.
- Do not smoke or allow open flames or sparks nearby, within 50 feet (15 meters), of the fueling area.
- If equipped, close all doors, windows, hatches and ports.
- Determine the amount of fuel required to fill the tanks. Do not overfill the fuel tanks. Allow for at least a 2% expansion of fuel when refueling. If the fuel temperature is 32°F (0°C) or lower, allow at least 6% for fuel expansion.

## REFUELING

The fuel filler on boats with built-in tanks is usually located on the gunwale or aft area. The fuel tank is equipped with either a shutoff valve or antisiphon valve. The shutoff valve requires you to manually turn the fuel valve, while the antisiphon valve operates automatically. Because gasoline fumes are heavier than air, they will sink to the lowest part of your boat, such as the bilge. Always evacuate fumes with the bilge blower (if equipped) before attempting to start the engine.

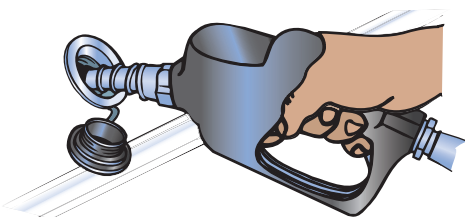

KC-0027C-A

### NOTICE

**To prevent unwarranted engine damage, refer to the Engine Operator's Manual for recommended fuel and oil specifications.**



### CAUTION

**The fuel tank may be under pressure. Remove fuel filler cap slowly to release any pressure.**



## REFUELING BUILT-IN FUEL TANKS

When refilling a permanent fuel tank from a land-based fuel nozzle with the boat out of the water, maintain contact between the fuel nozzle and the fill pipe at all times, before and during refueling, to prevent an electrostatic spark. If it's necessary to use a funnel, use a metal funnel. Do not use a plastic funnel. Do not fill built-in tanks from unapproved portable containers.

When refilling a permanent fuel tank from an approved portable fuel container with the boat in the water, a plastic funnel may be used.

### NOTICE

*If the boat is unlikely to be used for two weeks or more, and you are using an ethanol-blended fuel, fill only the amount of fuel you need plus 10% as a safety factor. Unused ethanol-blended fuel deteriorates quickly.*

## AFTER REFUELING

- Close the fuel fill cap thoroughly.
- Wipe up any spilled fuel completely. Dispose of rags properly onshore.
- Open all doors, windows, hatches and ports to ventilate all spaces. Check for fuel vapors before starting any engines or appliances.
- If equipped, operate the blower for a minimum of four minutes before starting the engine.

## LAUNCH

- Operate the blower for at least four minutes before starting engine.
- Check bilge for leaks.
- Stow gear and clothing.

## STARTING



### DANGER

***Gasoline vapors can explode, resulting in serious injury or death.***

- Before starting engine, check the engine compartment for gasoline or gasoline vapors, then run blower for four minutes.
- Run blower below cruising speed.
- Run the blower for at least four minutes before starting the engine. If you smell gasoline fumes, do not start the engine. Continue to run the blower until fumes have dissipated.



- Make sure the saltwater flush kit shut-off valve (if equipped) and seacock on water pickup are open (handle in-line **[OPEN]** with hose, not perpendicular **[CLOSED]**).
- Make sure the emergency stop switch is attached to the switch and the lanyard is attached to the operator.
- Make sure the shifter/throttle control handle is in **NEUTRAL**.
- Turn the key clockwise to the **START** position. After the motor starts, release the key.
- Push shifter/throttle control handle forward to go forward, pull back for reverse.

Always pause in **NEUTRAL** before going into **REVERSE** to avoid taking water in over the transom.

## STEERING

Practice steering your boat. Make sure the steering system is working correctly and is properly maintained. Have the steering system checked regularly.



### **WARNING**

***Loss of Control and Unsafe Boat Hazard: Hazard from improper maintenance of steering system is hazardous and can cause death or serious injury from sudden loss of control. Make sure all steering hardware, cables and fluid levels are regularly inspected and maintained.***

Boats have a tendency to wander at slow speeds and steering the boat back and forth will result in over-steer. Keep the steering wheel in the center position and make slight adjustments.

## SHIFTING

The following information is a basic guideline only and may not apply to the specific shift control. See the *Engine Operator's Manual* or control manufacturer's information for the shift control operation, adjustment and maintenance.

- Most side-mounted throttle and shift controls have a neutral detent lock that must be released before shifting from **NEUTRAL**.
- Always use a brisk and decisive movement when shifting into or out of gear.
- Always pause in **NEUTRAL** before shifting from **FORWARD** to **REVERSE**, or **REVERSE** to **FORWARD**. Most throttle and shift controls have a detent position for **NEUTRAL**, **FORWARD** and **REVERSE** engagement positions. These detent positions are important; when shifting into and out of gear, always pause in these positions.



- Never shift into REVERSE while your boat is in FORWARD gear when traveling at any speed above idle.
- Always keep the shift control clean and clear of obstructions.

## STOPPING

1. Slowly bring the shifter/throttle control handle to the idle position. If the boat has been driven for a long period of time at high speed, allow the engine a two- to three-minute cooldown period at idle.
2. Turn the ignition key to the **OFF** position.
3. If any problems were encountered during the outing, have the boat inspected by your dealer and request any necessary repairs before the next outing.

**DO NOT use the emergency stop switch to shut off the engine.**

## CHECKS AFTER OPERATION

- Fill fuel tank to prevent moisture from condensation.
- Check for fuel, oil and water leakage.
- Check the propeller for damage.

## DOCKING

Practice docking before attempting it for the first time. Use a float, like a plastic milk jug with a line and small weight, as your docking target. Remember, your boat is steered with a rudder and maneuvering at slower speeds takes practice.

 **WARNING** *Crush Hazard: DO NOT use any body part to keep the boat from hitting the dock. Using your hand, arm, or other part of your body to attempt to keep the boat from hitting the dock can result in serious injury.*

## DOCK AND MOORING LINES

Use enough fenders to protect the craft from damage and good quality double-braided nylon line. Only use the cleats, bow eye and stern eyes to secure the craft. **DO NOT** use the handrails or windshield. The foredeck handrails should only be used for tying a “jackline” in an emergency situation.

**Follow these guidelines when docking:**

- Approach docks slowly with the starboard side of the boat if possible.
- Come to a stop a short distance from the dock, then proceed slowly.
- Have fenders, mooring lines and crew ready.
- If your boat has limited visibility from the helm, hand-held communicators can be helpful.
- Observe how the wind and current are moving your boat. Approach the dock with the boat pointed into the wind, if possible. If the wind or current is pushing you away from the dock, use a sharper angle of approach. If you must approach the dock downwind or down current, use a slow speed and shallow angle. Be ready to reverse to stop and maintain position.
- If there is no wind or current, approach the dock at a 10- to 20-degree angle.
- If possible, throw a line to a person on the dock and have that person secure a bow line.
- With the bow secure, swing the stern in with the engine, or pull it in with a boat hook.

If the boat is to be moored for a long period of time, use chafing protectors on lines to protect the gelcoat finish. Leave slack in the lines to allow for some wave movement or tidal action if applicable.

**Follow these guidelines when departing:**

- Very slowly shift into forward at idle speed.
- When the stern moves away from the dock, turn the engine away from the dock.
- Cast off bow line and back away.

If the wind or current is pushing away from the dock, cast off all lines and allow to drift until you are clear.



## TAPS OPERATION



For instant planing and clean, faint slalom wakes.



Adjust wake size or trim for optimum cruising, fuel efficiency, top speed or performance.



Convex V hull settles naturally at boarding and surfing speeds.



Working in conjunction with the patented Convex V hull, TAPS allows variable-hull trim capability that dramatically enhances wake characteristics, ride and overall boat performance. With the push of a button, TAPS instantly modifies the hull's running angle for optimum watersport wake enhancement, a smoother ride in rough water, better fuel economy and increased safety and comfort.

TAPS adjustments are made using the rocker switch located on the throttle handle. Always keep your left hand on the steering wheel and your right hand on the throttle.

The location of the TAPS switch allows operation with the right thumb, maintaining safe, hands-on control of the throttle.

TAPS switch adjustments can be made while stopped or while underway at any speed. The position of the TAPS plate is indicated on the TAPS gauge located top center of the Tigé CLEAR home screen.

Settings range from 1, a flat, bow-low running angle to 8, a bow-high running angle. To move the bow to a higher running attitude, push the top of the TAPS rocker switch (the TAPS will raise). The TAPS gauge will begin moving toward a higher number. To lower the bow, push the bottom of the TAPS rocker switch. The bow angle will lower and the TAPS gauge will move to a lower number.

Although the effects of the various TAPS settings depend on Tigé model, passenger load, water conditions, speed and other factors, the following guidelines are provided as a starting point as you learn to use TAPS to optimize your performance needs. Practice and experience using TAPS can also optimize your performance needs.





## TAPS 3T OPERATION

The TAPS 3T Surf System with the surf link remote changes how you wakesurf. TAPS 3T allows riders to switch sides, style, size instantly. TAPS 3T conquers the demands of convenience and quality, all while intuitively connecting riders to their surf wave like never before. In tandem with Convex V Hull, TAPS 3T's list-enhancement capabilities will result in the quickest, cleanest, most powerful transfer, and surf wave that's second to none.?

TAPS 3T is set up to make surfing either side of the wave easier.

- To use TAPS 3T select the GO page on the home screen of the Tige CLEAR screen. Select Surf then press GO, this will bring you to the Surf screen and turn TAPS 3T on.
- To surf on the left side select the arrow located to the left of the Go Surf tab. To adjust the size and shape of the wave use the mellow to steep icon levels.
- To surf on the right side select the arrow located to the right of the Go Surf tab. To adjust the size and shape of the wave use the mellow to steep icon levels.
- To utilize TAPS 2 to provide further wave adjustment select the wavetune icon to adjust the TAPS 2 value.

The amount of ballast and the amount of people can affect the way the wave forms. With most boats, a general setting for TAPS 3T to provide the best wave is between 3-5 on the mellow and steep level. TAPS 3T works alongside TAPS2, which should be set between 4 and 6. The ideal speed varies between 10.6 and 12.2 MPH. Remember these are guidelines and the plates and speed should be adjusted depending on how much weight is in the boat.

The Surf Link remote allows the rider to transfer waves by pressing either the left or right arrow on the remote depending which side of the wave you are switching to. When pressed the TAPS 3T system will raise one plate and lower the the other plate to allow the rider to transfer waves. The UP and DOWN arrows allow the rider to adjust the TAPS 3T plates in order to create a more steep or mellow wave.



## RIDE, SAFETY AND BOAT PERFORMANCE

The variable-hull TAPS 2 system also dramatically enhances boat performance, comfort and safety. To eliminate bow rise on take-off, set TAPS 2 at 1. As soon as the boat reaches planing speed, adjust TAPS 2 to 3T or higher, depending on water conditions. If the water is choppy, less than 6 in. (152.4 mm) waves, the optimum ride setting will be from 2 to 5, depending on Tigé model and passenger load. If the water is rougher, 6 to 12 in. (152.4 to 304.8 mm) waves, the optimum ride setting will be from 5 to 8, depending on Tigé model and passenger load.

Raising the bow in rougher water will provide a safer, drier ride while maximizing the hull's "entry vee" to reduce the effects of the chop. This higher running attitude will also provide bow passengers with a smoother, drier ride.

To maximize top speed in your Tigé, set TAPS 2 between 5 and 8. When the boat reaches top speed, bring the TAPS 2 setting down slightly to achieve the optimum running attitude. Top speed should be achieved at a TAPS 2 setting of 5 to 6.

## ZERO OFF GPS CRUISE CONTROL OPERATIONS

Zero Off GPS Cruise Control allows precise, easy-to-use digital speed control that is useful in towing wakeboarders and skiers or maintaining a constant cruising speed. The Zero Off GPS Cruise Control panel incorporates touch pad recognition for easy fingertip use without taking your eyes off the waterway.

Before using Tigé Zero Off GPS Cruise Control take time to familiarize yourself with the system and its operations.

The system will only operate when the dash CRUISE CONTROL switch is toggled ON. If this switch is toggled **OFF** during Zero Off GPS Cruise Control operation, the system will disengage as soon as the throttle is brought back below the set point.

Zero Off GPS Cruise Control resets each time the **CRUISE CONTROL** switch is manually toggled off and the throttle arm is brought below the set position.

Zero Off GPS Cruise Control is solely governed by the throttle. If you desire to stop your boat at any time, pull back on the throttle arm.



## TO SET ZERO OFF GPS CRUISE CONTROL

The cruise control can be toggled off using the Zero Off button on the Tige CLEAR XL Touch Screen. When the button is orange, cruise control is enabled. To adjust the set speed, use the +/- buttons below the speedometer.

The cruise control can also be engaged and adjusted through the Smart2 Wheel controls (if equipped), or through the small cruise control button in the lower left-hand corner of each screen.

Pulling the throttle arm back will instantly disengage Zero Off GPS Cruise Control, allowing the boat to slow or come to a stop. Zero Off GPS Cruise Control will allow slowing and stopping, it will not allow the boat to go over the set speed. For example, if you are towing a skier at a set speed and the skier falls, simply pull back on the throttle arm. The boat will slow and you can resume normal throttle operation to turn around to pick up the skier. As long as the CRUISE CONTROL switch remains ON, Zero Off GPS Cruise Control will remember the set speed. To begin towing the skier again, push the throttle arm completely open and Zero Off GPS Cruise Control will accelerate the boat to the previously set speed.

### ***To Increase Speed While Using Zero Off GPS Cruise Control***

There are two ways to go to a higher speed:

1. Hold down the FASTER button and release it when you reach the desired speed.

OR

2. Press the FASTER button in increments (about a half a second each time).

Each time the FASTER button is pressed, your speed increases by about 0.1 MPH.

This is useful for small speed changes desired by the person being towed.

For example, if you desire to go 1 MPH faster, press the FASTER button ten times (about a half second each time).



### ***To Reduce Speed While Using Tigé Zero Off GPS Cruise Control***

**There are three ways to reduce your speed:**

1. Hold down the SLOWER button and release it when you reach the slower speed.

OR

2. Press the SLOWER button in increments. Each time the **SLOWER** button is pressed, your speed decreases by about 0.1 MPH, the same increment as the FASTER button.

OR

3. Pull the throttle arm back to your desired speed.

**To erase the Zero Off GPS Cruise Control memory and regain throttle authority, turn OFF the CRUISE CONTROL switch on the dash.**

For example, if you are cruising using Zero Off GPS Cruise Control and want to regain throttle authority for quick acceleration, simply toggle the Cruise Control switch **OFF** (this resets the memory), back off the throttle and then move it forward to achieve your desired speed. This can be done quickly or slowly.

## **TROUBLESHOOTING**

***No throttle power when you start your boat engine:***

Move throttle to neutral and verify that the dash Cruise Control switch is toggled OFF.

***Boat does not seem to maintain speed on turns or in rough waters:***

Verify that you have given your boat plenty of throttle authority (move the throttle forward).

***Engine power cuts out and then in:***

This usually occurs when the throttle is positioned at, or near, the set speed. Move the throttle to the full forward position after the speed is set, giving Zero Off GPS Cruise Control adequate throttle authority.



## RUNNING

We urge you and all others operating the boat to seek certified instruction from local boating authorities.

This section is designed to present the most basic operational principles. It is not intended to cover all conditions encountered during operation.

The principles presented in this manual are limited to the facts related directly to the operation of the boat, while the responsibility for the proper application of these principles belongs to you.

## MANEUVERING TECHNIQUES

Steering response depends on three factors: engine position, motion and throttle.

High-speed maneuvering is relatively easy and takes little practice to learn.

Slow-speed maneuvering is more difficult and requires time and practice to master.

When making tight maneuvers, it is important to understand the effects of turning. Since both thrust and steering are at the stern of the boat, the stern will push away from the direction of the turn. The bow follows a smaller turning circle than the stern.

The effects of unequal propeller thrust, wind and current must also be kept in mind. While wind and current may not always be present, an experienced boater will use them to their advantage. A counterclockwise rotation propeller tends to cause the boat, steering in the straight ahead position, to drift to port slightly when going forward, and to starboard when going backward. At high speed, this effect is usually unnoticed, but at slow speed, especially during backing, it can be powerful. More experienced boaters approach the dock with the starboard side of the boat toward the dock, if possible.

Stopping (checking headway) is a technique that must be developed. Since a boat has no brakes, reverse thrust is used to slow and stop the boat. The momentum of the boat will vary according to the load as well as the speed.

Make it a practice to slow to idle (no-wake) speed before shifting into reverse.

It is best to learn maneuvering skills in open water away from traffic. Practice is the only way to develop your boating skills.

## SALT WATER

If boat is used in salt water or brackish water, allow the cooling system to drain thoroughly after removing the boat from the water. Hose down the entire hull with fresh water and wipe dry.



## **SALT AND HARD WATER OPERATION**

Your engine is capable of operating in brackish or salt water as well as in hard water or water with high mineral content as long as certain precautions and maintenance procedures are followed. Your dealer will be aware if the local freshwater lakes in your area will require any special precautions to keep your engine functioning properly. Damage to the engine, both internal and external, that is a result of inadequate salt or hard water maintenance will not be covered under the Indmar Limited Warranty.

## **EXTERNAL CARE**

Your engine has been carefully primed and painted to protect it against rust and corrosion. To keep your engine looking like new, apply an anti-corrosion compound. Regular application (every 3 months) of this protectant, particularly on exposed metal surfaces, motor mounts and electrical connections, will displace water and seal the surfaces against penetration by corrosive agents. Rinsing the engine with fresh water between applications of the protectant will further protect the exposed surfaces.

## **INTERNAL (COOLING SYSTEM) CARE**

### **FRESHWATER COOLING – HALF SYSTEMS**

A freshwater cooling system that uses antifreeze in the engine but raw water in the exhaust manifolds is referred to as a half system. Although the engine is protected, it is still important to flush the engine with fresh water to remove as much salt water as possible from the raw water side of the cooling system as well as from the exhaust manifolds and risers. For more convenient flushing, ask your dealer about permanently installing a flushing device that allows easy connection of a water hose.



## FRESHWATER COOLING

All freshwater cooling systems must be inspected and maintained annually, usually during winterization.

**Cylindrical Heat Exchanger** – Remove the end caps to drain and inspect the heat exchanger. Clean out any debris. Make sure you inspect the end caps for contour and cracks and replace the neoprene gaskets before putting the boat back in service. If you find rubber bits in the exchanger, check the raw water pump impeller.

**NOTE** — If you use a clean-out rod, it should be softer than the copper tubes, and should not be used to dislodge materials that are firmly stuck to the tube surface, as this could damage the tubes. The rod will assist in cleaning out bits of grass, zinc, shells, and similar materials that are just lodged in the tubes.

**Zinc Anodes** – The sacrificial zinc anodes in the cylindrical heat exchangers frequently spall, and there will probably be zinc bits in the exchanger that should be cleaned out. Inspect the zinc anode often during use and replace when it is 3/4" (19 mm) or less.

SACRIFICIAL ANODE  
REPLACE IF ANODE IS  
3/4" (19 mm) OR  
LESS IN LENGTH

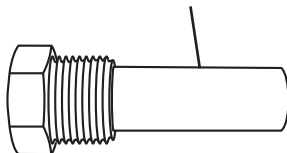

INDM-B007



**Raw Water Pump** – Replace the impeller if it is worn or each year. Since you must remove the impeller to inspect it, it is good practice to replace the impeller every year as a routine. Be sure there are no impeller parts lodged in the hoses or elsewhere in the system, as they will eventually move to a different place and restrict water flow. The raw water pump impeller should be replaced every year or whenever it is found to be worn or have damaged blades. Be sure to reassemble with the proper gaskets.

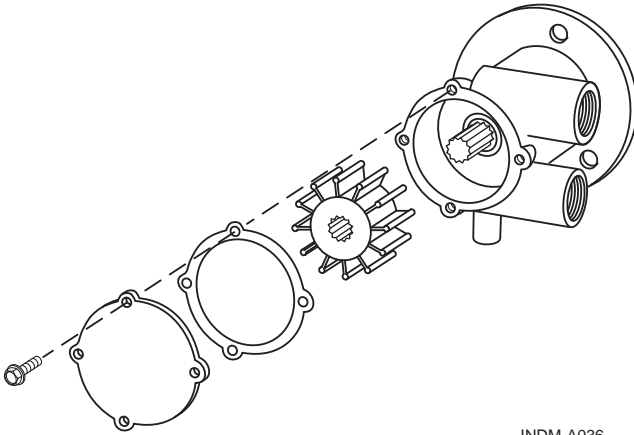

INDM-A036

## WINTERIZATION

At the end of the season and before the temperatures drop below freezing, drain the engine completely when the boat is removed from the water. Your Tigé dealer can provide the service.

## TOWING PROCEDURE

If water is rough, it may not be easy to extend the tow line from one boat to another. In these cases, use a light throwing line with a weight on one end and with the heavier towing line secured to it.

Never attempt to tow a much larger or grounded vessel. Because of the tremendous stress caused by towing, use a tow line that is rated at least four times the gross weight of the boat being towed. Tow ropes must always be in good condition, free of any cuts or abrasions.





Attach tow line to the bow lifting eye on the disabled boat. Attach the opposite end of the bridle only to the stern lifting eyes of the tow boat. Wrap the bridle with chafing gear where it rubs against the boat or any corners. Leave at least two boat lengths between the boats for adequate movement.

When towing, use only the bow and stern eyes; never use cleats, handrails, etc. Do not allow anyone to be in line with the tow rope. If the rope should break or pull free, a dangerous recoil could occur.

Adjust the tow line to match wave action. Keep the boats on the crest or in the trough of the waves at the same time. In protected, calm waters, shorten the line for better handling. Always tow at moderate speed, allowing for adverse wind and wave conditions. Have the operator of the towed boat steer with you if possible.

If you need a tow, or wish to tow another boat, use great care. The boat structure can be damaged by excessive pulling strain. You should always offer help to a boat in trouble; however, towing a capsized, grounded, or hull-damaged boat is dangerous. Give assistance to the occupants, and then call the proper authorities.

## ANCHORING

### DROPPING ANCHOR

There are many types of anchors available on the market. The choice of one anchor over another depends on many factors. An anchor will usually hold best in a mixture of mud and clay or in hard sand. A lightweight Danforth anchor is recommended for general boating. For more information on anchors, see your dealer.



#### **WARNING**

***Sinking or Drowning Hazard: Anchoring at the stern can pull a boat under water and keep it there.***

***DO NOT anchor at the stern.***

- Make sure the line is tied to the anchor and tie the other end of the line to the bow lifting eye. Having approximately 2 feet of heavy chain between the line and anchor will help the anchor place.
- Head the boat into the wind or current over the spot where you want to lower the anchor.
- Scan the shoreline for signs of underwater cables or pipes and avoid these areas.
- Stop the boat before lowering the anchor.



- When the anchor hits bottom, slowly back up the boat, keeping tension on the line. Let out an anchor line that is four to six times the depth of the water. For example, if you are in 10 ft (3 m) of water, let out 40 to 60 ft (12 to 18 m) of line.
- Secure anchor line to the bow-lifting eye. Pull on line to make sure anchor is holding.
- Occasionally check your position against the shoreline. If the anchor is dragging and you are drifting, reset the anchor.

## **WEIGHING (PULLING IN) ANCHOR**

Start engine and move forward until anchor line is straight up and down.

Pull hard to lift anchor from the bottom material. If the anchor is stuck, allow the up and down motion of the bow from wave action to loosen the anchor from the bottom. If the anchor remains stuck, slowly maneuver the boat around the anchor until the anchor pulls loose. Be sure to keep the line tight during this procedure.

## **PERFORMANCE BOATING**

Some boat models, especially those with high horsepower engines, are capable of truly exhilarating performance. Do not be tempted to push your boat to its limits until you are completely familiar with the boat's operating characteristics. The operator should have at least 10 hours of experience with the boat before any extended full throttle operation.

Here are some guidelines for performance operation. Read and practice them, and soon you will be operating your boat to its full capability.

## **BEFORE RUNNING**

- Keep the bottom clean and free of scum, barnacles and other growth. Growth on the hull can slow the boat down considerably.
- Prepare the boat. Be sure all gear is properly stowed and compartments are latched.
- Keep weight in the boat low and evenly distributed. Remove unnecessary weight and keep it onshore. Weight distribution affects performance.
- The propeller should be of the proper pitch to turn the recommended RPM rating for the engine and of the proper type for your average load and individual requirements. Your Tigé boat is already equipped with the proper propeller to achieve maximum performance with an average load for your boat. If you have questions, see your Tigé dealer.



## WHEN UNDERWAY

If the boat begins to operate in an unsafe way, pull back on the throttle. Monitor the gauges when operating at full throttle.

As the boat begins to get on plane, acceleration will increase since less boat will be in the water.



### WARNING

***Loss of Control and Unsafe Boat Hazard: Failure to maintain control can cause death or serious injury. Keep one hand on the wheel and the other on the shifter/throttle control handle.***

High-speed operation on smooth water is very stable, but quick reactions and adjustments are needed to maintain control. Know your limits and stay within them. Always keep one hand on the steering wheel and the other on the throttle; constant adjustments are necessary for rapidly changing conditions. Small inputs of throttle and steering are exaggerated at high speeds. Depending on the speed, keep watch well ahead so that you may have enough time to react.

## PROPELLERS

The propeller converts the engine's power into the thrust needed to propel the boat. Care and selection of your propeller is very important to proper boat operation. Propellers are identified by two numbers, such as 13 x 19. In the number sequence, the first number is the diameter of the propeller and the second is the pitch.

Pitch is the angle of the blades expressed in the theoretical distance a propeller travels in each revolution. In the above example, the pitch is 19, or each revolution of the propeller pushes the boat 19 in. (483 mm) through the water. A 19 pitch is considered "higher" pitched and a 15 pitch propeller is considered "lower" pitched.

Your Tigé boat is already equipped with the proper propeller to achieve maximum performance with an average load, for your boat. If you have questions, see your Tigé dealer.

Keep these guidelines in mind when selecting a propeller:

- Engine RPM must be within the recommended operating range. Refer to the engine owner's manual.
- Higher propeller pitch reduces: RPM, acceleration and engine noise, and usually improves fuel economy and top speed.
- Lower propeller pitch increases: RPM, acceleration and engine noise, and reduces fuel economy and top speed.

Refer to Section 11, MAINTENANCE, Propeller, for information on removal and installation.



SECTION

# 8

## OPERATING THE BOAT

This Page Intentionally Left Blank

# Section 9

## BOAT SYSTEMS

Knowing the systems on your Tigé boat is as important as knowing the switches, controls and indicators on your boat. System knowledge is essential for safe and proper operation and integrity.

When replacement parts are required, **DO NOT substitute marine-grade parts with anything other than parts with equivalent characteristics, including type, strength and material.**

Marine-grade parts are specifically designed for the conditions and environment which marine products are exposed to. Using substandard parts could result in injury and product failure.

 **WARNING** *Fire or Explosion Hazard: Gasoline and other fuels are extremely flammable and highly explosive under certain conditions.*

- **DO NOT smoke or allow open flame or sparks nearby when refueling.**
- **DO NOT block fuel vents.**
- **DO NOT store fuel in any containers or compartments which are not designated for fuel storage and DO NOT use these storage areas for any other purpose.**

 **WARNING** *Loss of Control and Unsafe Boat Hazard: Improper maintenance of boat systems is hazardous and can cause death or serious injury from sudden loss of control. Make sure all systems are regularly inspected and maintained.*

 **WARNING** *Flooding or Drowning Hazard: A water system component failure is a flooding or drowning hazard which can cause death or serious injury. Maintain all water system components and keep seacocks closed during periods of inactivity.*

## STEERING SYSTEM

Your Tigé boat has a mechanical steering system. When the steering wheel is turned, the dash unit transfers rotary motion of the wheel to linear motion in the cable, which pushes or pulls the rudder arm.

Boat steering is not self-centering. Always keep a secure grip on the steering wheel to maintain control. Improperly maintained controls are dangerous.

Check steering operation and visually inspect for loose or missing hardware before operating the craft. If you suspect the steering system is damaged, see your dealer. **DO NOT** operate the craft if you suspect the steering system is malfunctioning.



## ENGINE

Your Tigé boat is powered by a single inboard engine. The specific operation, specifications, maintenance and troubleshooting information is contained in the engine owner's manual included in your Owner's Kit. Familiarize yourself with the information contained in the engine owner's manual. Following the manufacturer's recommendations and guidelines will provide you with continued boating pleasure and engine integrity.

## TRANSMISSION

The transmission has one forward and one reverse speed, and is shifted by the shifter/throttle control handle.

## V-DRIVES

The power generated by the engine is transmitted as a combination of the straight inboard and the V-drive transmission (a series of gears), which drives the shaft coupling and the propeller shaft assembly. The propeller shaft is supported and aligned with the engine by a thru-hull shaft log and an outside strut.

## PROPELLERS

The propeller installed on your Tigé boat was selected because of its diameter and pitch to provide the optimum speed and performance under average conditions of load. The propeller selection must be based on the ability of the engine to turn the propeller and achieve the manufacturer's recommended RPM at full throttle.

## STRUT AND BEARING

The propeller shaft is supported on the outside of the hull by a strut. The strut is equipped with a water-lubricated plastic bearing to allow the propeller shaft to rotate in the strut.

### **NOTICE**

*The strut bearing is lubricated by water. DO NOT shift the transmission and run the propeller out of water even if the water is supplied to the engine's cooling system. Damage to the shaft and bearing can occur.*



## ELECTRICAL SYSTEM

Your Tigé boat is equipped with a direct current (DC) system which is battery-powered and supplies electricity to lights, pumps, blowers, engine ignition and accessories. The alternator from the engine produces alternating current (AC) and converts it to DC, which provides power while the engine is running and also charges the battery or batteries, if your boat is equipped with more than one battery.

The electrical system is controlled by the battery disconnect switch, with location varying based on model. The electrical system is protected by circuit breakers on the breaker box. The breaker box is located under the dash. Make sure the battery disconnect switch and the MAIN switch on breaker box are both ON and make sure no breakers are tripped. Run fingers over breaker face and reset any tripped circuit breakers.



### **WARNING**

***Fire or Explosion Hazard: An AC/DC system can create sparks. In the presence of explosive gases, fire or explosion can occur. Check for explosive gases or run the blower.***

**DO NOT work on an energized system. Disconnect the negative cable from the battery before performing any service.**

## FUEL SYSTEM

The fuel system consists of a built-in fuel tank, a fuel tank vent, a port and/or starboard fuel fill on V-drive models.

The fuel tank is located mid-ship, fore of the engine. To inspect the hose connections, raise the floor panels. Your Tigé dealer or a qualified service technician should perform all fuel system service.

## BALLAST SYSTEM

Your Tigé is equipped with a subfloor ballast bag system containing 3 or 4 ballast bags, depending on the model of your boat. Each bag has both fill and drain pumps, which are controlled through the touch screen.

Your ballast system is also pre-plumbed to use Plug and Play ballast bags in certain storage compartments. If you are unsure how to install the Plug and Play bags, please contact your dealer.



### **WARNING**

***Sinking Hazard: Do not exceed the U.S. Coast Guard weight or persons capacity at any time. Maximum weight capacity is the combined weight of all passengers, ballast and gear. The weight capacity and other safety information can be found on the labels near the helm.***



Using the “Go System” on the touch screen will automatically provide the best cruise control, ballast and TAPS settings for wakeboarding or wakesurfing under typical loads. Settings may need to be adjusted for larger crews or personal preference.

**IN ALL CASES, NEVER EXCEED THE U.S. COAST GUARD WEIGHT CAPACITY AS INDICATED ON THE CAPACITY LABEL.**

## BILGE SYSTEMS

### IMPORTANT

**Bilge pumps and bilge pumping systems are not designed for damage control. Check the function of all bilge pumps at regular intervals. Debris can also prevent pumps from functioning or also make it operate continuously. Make sure no debris is blocking the bilge pump float. Continuous operation of the bilge can mean a leak or a drain plug is installed incorrectly; make sure all drain plugs are installed. See your Tigé dealer if you have any questions.**

**DO NOT allow water to accumulate in the bilge area of your boat.** When the boat is in use, check the bilge area often. Your Tigé boat is equipped with an automatic bilge pump which detects excess water accumulation and will turn the bilge pump on automatically. Bilge water normally accumulates from weather, wet water sports gear, getting into your boat from the water and draining coolers.

The engine and other parts of the drive system could be damaged and there is a risk of personal injury as increasing water level will affect the handling and maneuverability of the boat.



### **CAUTION**

***The risk of personal injury from excess water in the bilge area will adversely affect the handling and maneuverability of the boat. Also, damage to the engine and other parts of the drive system can occur from the additional water. DO NOT allow the bilge pump to operate after all the water has been cleared from the bilge area. Damage to the pump will occur.***





## STERN THRUSTER (OPTIONAL)

While the engine is running, the stern thruster can be used to turn the boat in a tight circle. The stern thruster is controlled through a toggle switch on the front of the throttle. This switch is on the front side of the shifter. Pressing the switch upward will turn the bow of your boat to starboard, and pressing the switch down will turn the bow of your boat to port.

The thruster is powered by a separate deep-cycle battery, and the voltage for this battery is displayed on the circular digital gauge above your ignition key panel. Using the thruster for long periods of time may cause the voltage of this battery to drop. The alternator will recharge the battery while the thruster is not in use. If the display gets below 9 volts, the battery will not recharge unless you recharge the battery. Make sure to stop using the thruster if it gets close to 9 volts on the display.

If the thruster isn't running, check to see if the breaker has tripped. You can find the 250-amp breaker in the starboard bow leanback mounted under the power distribution model (PDM).

 **WARNING** *Sever Hazard: The stern thruster has a powerful, high-speed propeller inside of its housing.*

- ***Never put any part of your body into the housing of the thruster, and use caution when performing service in this area. Service should never be performed on or near this component when the battery switch is ON.***
- ***Never use the thruster when anyone is in the water near the boat.***

## TRANSOM FLIP-UP SEATS (ZX/RZX LINE)

The engine hatches of your boat can be converted into lounge seating. To use them, lift up on the forward section of the cushion so that it releases from the stowed position. Once the backrest is lifted up, push the bottom of the backrest towards the front of the boat to lock the backrest in place. To lower the backrest, grab the handle on the backside of the backrest and pull it towards the front of the boat. This will allow the backrest to return to the stowed position.

## TRANSOM FLIP-UP SEATS (Z LINE)

The engine hatches of your boat can be converted into lounge seating. To use them, lift up on the forward section of the cushion so that it releases from the catch mechanism. The kickstand for the backrest will lock into the openings in the hatch when it reaches the chosen position. To store the seat, lift the kickstand out of the opening and allow the backrest to lay back down into place. Make sure that the backrest fits into the catch mechanism when it is in the stowed position.



## EZDRIVE THRUSTERS

### IMPORTANT THRUSTER USER PRECAUTIONS AND CONSIDERATIONS

#### NOTICE

*Failure to follow these warnings may cause serious injury or damage and will void all warranty.*

- Ensure you know the location of the main battery switch that disconnects the thruster from all power sources (batteries) so the thruster can be turned off in case of serious malfunction, AND **Always** turn the main power switch off before touching any part of the thruster, an incidental start while touching moving parts can cause serious injuries.
- Always turn the control device off when the thruster is not in use, and when leaving the boat always turn off power to the thruster.
- The maximum continuous run time of the thruster is approximately 3 continuous minutes after which it can be restarted by merely toggling the directional switch for a total run time of approximately 10 minutes before overheating. The motor has a built-in thermal cut-off switch that will shut it off if it is overheating and can be re-engaged when it has cooled down. Consider this when planning your maneuvering.
- Do not depend on the thruster to move or hold the boat in position against a strong current or side wind for extensive periods.
- **Never** use the thruster close to objects/ persons or animals in the water, as the thruster may draw objects into the tunnel and into contact with the rotating propellers and cause serious injuries and/or damage to the thruster.
- If the thruster is out of the water, only run it for a fraction of a second to test, since without resistance it will accelerate very fast to a potentially damaging rpm. In addition, ensure that the propeller has come to a complete stop before testing a directional change, as it might cause damage to the thruster.
- If the thruster fails to provide thrust while the motor is running, there is potentially a problem in the drive system. Therefore, immediately stop running the thruster and turn it off. Running the thruster for more than a few seconds without resistance of the propeller can cause serious damage to the motor.
- It is advised to keep the main engine running while using the thruster. This will keep the batteries in a good charge condition, and provide better



performance since a higher voltage to the thruster results in a higher torque (power) in the motor.

- Please note the performance of the thruster strongly depends on the voltage available to the electromotor. This voltage will decrease over time due to ageing batteries which have reduced capacity. In this case, installing new batteries will bring back the thruster to the original power level.
- If the thruster is not performing or functioning as usual, the cause should be found and corrected as soon as possible to avoid causing any other or further damage to the equipment. You must also turn off the main battery switch immediately in case the problem is of electric origin.
- The ez drive electronic components including the I box must be mounted so they will remain dry at all times.
- The primary purpose of the thruster is to help maneuver the boat for rapid turn around to pick up swimmers, saving fuel, increasing safety, docking the vessel and assisting getting the boat on to trailer.

**\*IT IS THE COMPLETE RESPONSIBILITY OF THE OWNER/ CAPTAIN/ OR OPERATOR OF THE BOAT TO ASSESS THE RISK OF ANY POTENTIAL INCIDENTS ON THE VESSEL, INCLUDING SWIMMERS/ OBJECTS IN THE WATER NEAR THE THRUSTER OR LOSS OF THRUSTER POWER DURING MANEUVERING, AND HAVE CONSIDERED A PLAN ON HOW TO AVOID INJURY TO PERSONS OR OTHER OBJECTS.**

**Warranty Activation**

Scan QR code below to register your ezDrive.



SCAN ME

Or use the following link:

**<https://www.ezDriveThruster.com/warranty-registration/>**

You will need the following information for registration:

- HIN (Hull Identification Number)
- Date and Place of Purchase
- Thruster Serial Number (if installed aftermarket)

***ezDrive Thruster Customer Care Hotline***

Telephone: 1-803-ezDrive (1-803-393-7483)

CustomerSupport@ezdrivethruster.com

\*\* Tampering with or dismantling thruster will void your warranty



## SCHEMATIC AND SYSTEM ILLUSTRATIONS

The schematic and system illustrations show models with the maximum components and accessories, which may not be included on your Tigé boat.

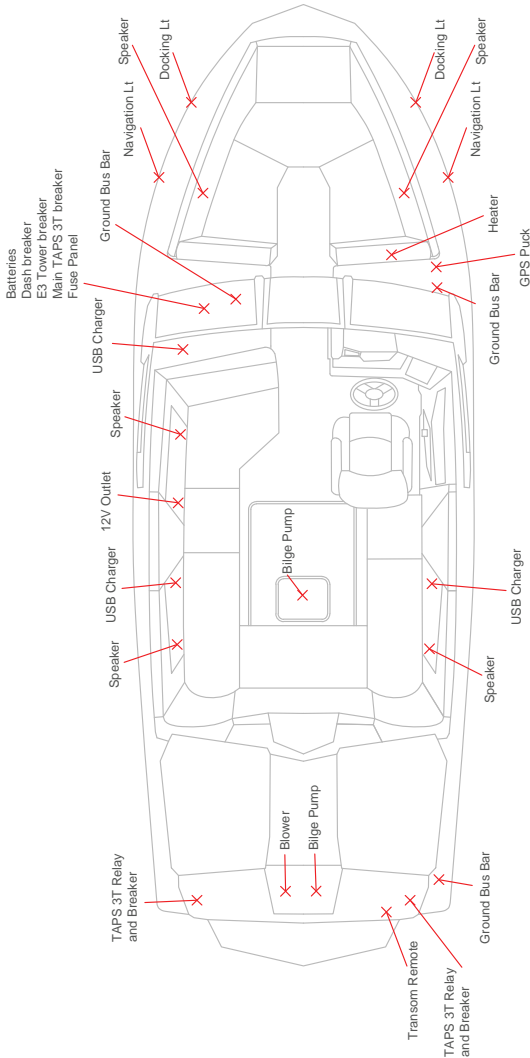

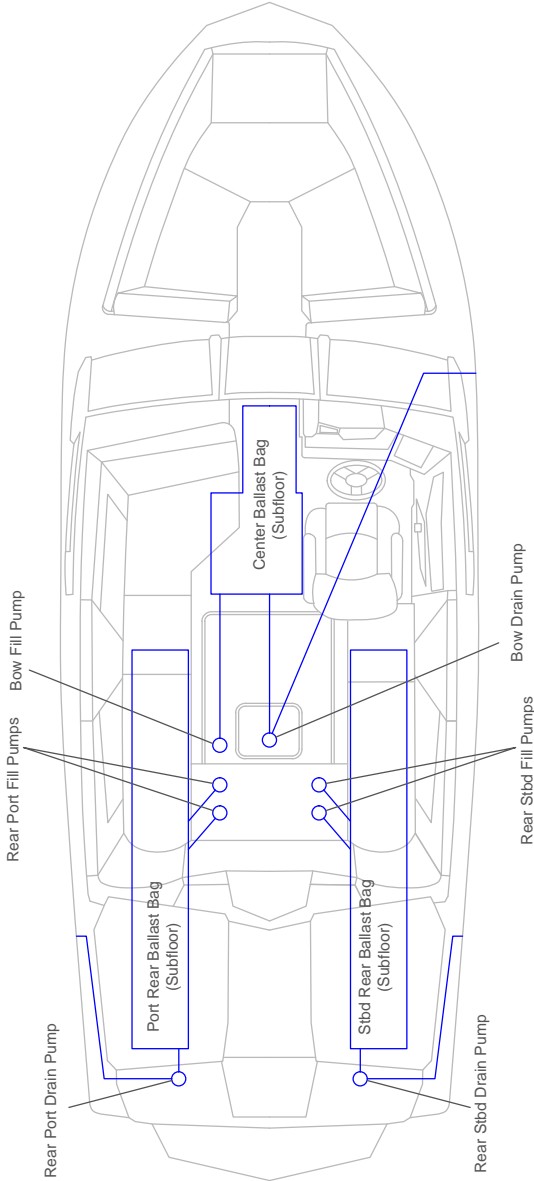

# Section 10

## TRAILERING AND LAUNCHING

Before using the trailer, review *Safety in Section 2*.

### LEGAL CONSIDERATIONS

The following information is intended as a basic guideline only. See the *Trailer Operator's Manual* for information on operation, adjustments and maintenance.

Before using the trailer, contact your state's Department of Motor Vehicles (and that of other states through which you may be traveling) for information on trailering regulations. Trailer regulations vary widely from state to state, and it is your responsibility to be in compliance with all regulations when trailering the boat.

Regulations include, but are not limited to, trailer registration, licensing, width, height, length, lights, safety chains, tie-downs, hitch type, weight capacity, brakes, spare wheels, vehicle mirrors and gross vehicle weight.

### TRAILER CLASSIFICATION

Trailers are separated into four classes based on the Gross Vehicle Weight Rating (GVWR):

TRAILER CLASS	GVWR
Class One	under 2000 lb (907 kg)
Class Two	over 2000 lb (907 kg) and under 3500 lb (1588 kg)
Class Three	over 3500 lb (1588 kg) and under 5000 lb (2268 kg)
Class Four	over 5000 lb (2268 kg)

### TRAILER TYPE

Trailers are designed for many applications and can vary in style. To prevent damage to the boat and/or personal injury, always use the appropriate trailer for proper support of the boat. Contact the dealer for more information.

## TRAILER GROSS VEHICLE WEIGHT RATING

All trailers must display a Gross Vehicle Weight Rating (GVWR) decal, which shows the load-carrying capacity plus the weight of the trailer. The total weight of the boat (fully loaded with fuel, batteries, water, etc.), engine, gear and trailer must never exceed the GVWR.

## TOWING VEHICLE

The towing vehicle must be able to safely pull the full trailer and boat load. Never pull a trailer load that exceeds the vehicle's towing capacity; you risk losing control of the trailer and/or vehicle. Before trailering, always check the *Vehicle Operator's Manual* for maximum towing/trailering load specifications and maximum gross vehicle weight specifications that include the fully loaded trailer.

## VEHICLE TOWING HITCH

The towing vehicle must be able to safely pull the full trailer and boat load. The vehicle must have a towing hitch that is capable of safely handling the trailering load and tongue weight of the trailer.

Hitches are designed for many applications and can vary in style. Use professional assistance when selecting the correct hitch and hitch ball for the towing application.

 **WARNING** *Control Hazard: A vehicle hitch that is underrated or improperly installed can lead to loss of control of the trailer and/or vehicle. Never use a hitch that is not rated to pull the maximum weight of the trailering load or that is not rated for the maximum tongue weight that the trailering load applies.*

Hitches are divided into classes that specify the trailer's gross trailer weight and maximum tongue weight for each class.



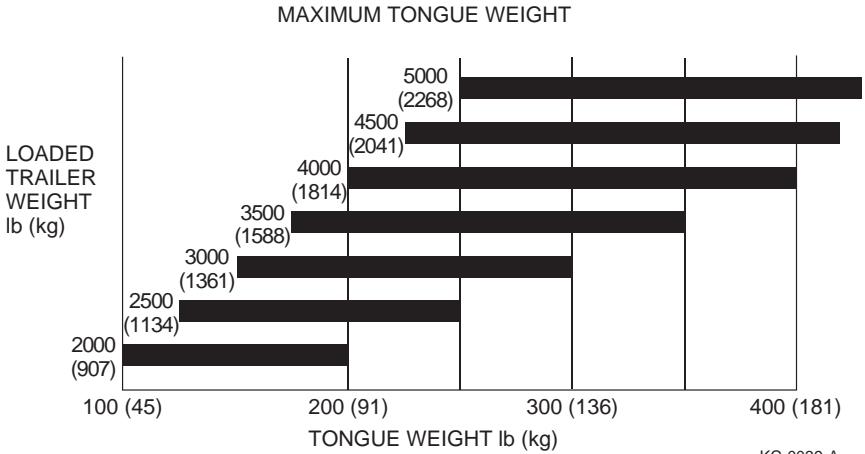

## HITCH BALL AND TRAILER COUPLER

Most boat trailers have a coupler that connects to a hitch ball attached to the towing vehicle's hitch. The trailer hitch coupler must always match the size of the hitch ball. The correct hitch ball diameter for the coupler is usually marked on the trailer coupler.

**⚠️ WARNING** **Control Hazard:** *Never use a hitch ball size or rating that does not match the trailer coupler specifications. Using an improper size or rated hitch ball can lead to loss of control of the trailer and/or vehicle.*

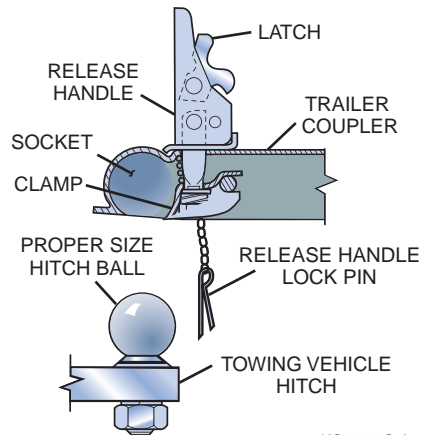

SECTION  
**10** TRAILERING AND LAUNCHING

Trailer hitch balls are sized and rated for use based on the trailer GVWR:

TRAILER CLASS	GVWR	HITCH BALL DIAMETER SIZE
Class One	under 2000 lb (907 kg)	1-7/8 in. diameter size
Class Two	over 2000 lb (907 kg) and under 3500 lb (1588 kg)	2 in. diameter size
Class Three	over 3500 lb (1588 kg) and under 5000 lb (2268 kg)	2 in. diameter size
Class Four	over 5000 lb (2268 kg)	2-5/16 in. diameter size

## SAFETY CHAINS

The boat trailer's safety chains prevent the trailer from completely detaching from the towing vehicle when underway. Connect the chains to the vehicle's hitch or frame and crisscross the chains under the trailer tongue to prevent the tongue from dropping to the road if the trailer separates from the hitch ball. Rig the chains as tight as possible with enough slack to permit full-free turning. Safety chains must be rated at the same or greater weight capacity as the trailer's GVWR.

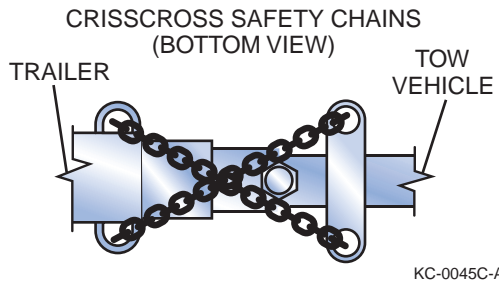

Never allow the chains to drag on the ground when trailering.

Attach the chains properly and securely between the towing vehicle and trailer before trailering.



## TRAILER BRAKES

In some states, any trailer with a GVWR of 1500 lb (680 kg) or more is required to have trailer brakes.

Check with your state and local authorities for more information.

The three basic types of trailer brakes are electric, hydraulic surge and air-actuated. If the trailer is equipped with brakes, see the *Trailer Operator's Manual* for more information on operation, adjustments and maintenance.

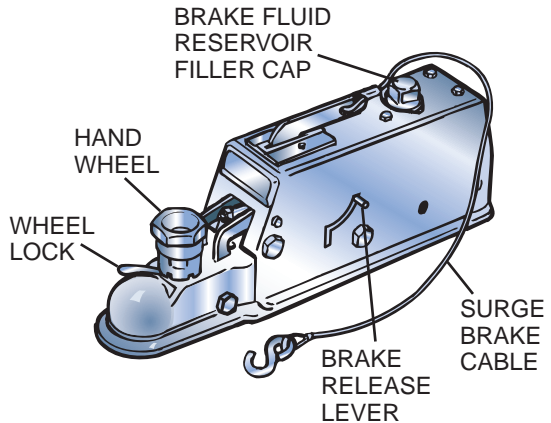

KC-0044C-B

## 5-PIN WIRING CONNECTOR

Some trailers equipped with surge brakes may utilize a 5-pin wiring connector. These trailers use an electric solenoid valve that allows brake fluid to bypass back to the reservoir while in REVERSE. The solenoid is usually connected to the reverse lights on the tow vehicle to ensure the brakes only bypass in REVERSE. The fifth pin is for deactivating the brakes when backing up, and is required to be connected to the vehicle's power when backing up.

## TRAILERING GUIDELINES

### ENGINE-TRANSOM SUPPORT BRACKET

The trailer must be equipped with an engine-transom support bracket for each engine. The support must transfer the weight of the engine to the trailer cross-member. Devices that are used between the engine and engine transom bracket do not provide adequate protection. Damage to the transom motor pod, engine and trailer from shock loads is not covered by the boat, engine or trailer warranties.

Follow these guidelines when trailering:

- Before driving, make sure the vehicle maintenance and trailer maintenance are current. This is very important because towing puts additional stress on the tow vehicle.
- Make sure the wheel lug nuts/bolts on the tow vehicle and trailer are tightened to the correct torque.
- Be sure the hitch, coupler, draw bar and other equipment that connect the trailer and the tow vehicle are properly secured and adjusted.
- Make sure all running lights, brake lights, turn signals and hazard lights are working.
- Verify that the brakes on the tow vehicle and trailer are operating correctly.
- Maintain a safe speed as regulated by the trailering laws of the state where you are traveling.
- Check the trailer and vehicle brakes for proper operation and fluid level prior to departure.
- Check the trailer for damage prior to departure.
- Make sure the hitch ball and trailer coupler are the same size and bolts and nuts are tightly secured.
- The coupler must be completely over the ball, and the latching mechanism must be locked down.

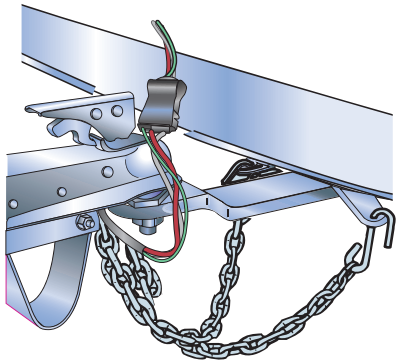

KC-0046C-A



- Make sure the safety chains are properly crisscrossed and connected. They should not touch the road but should have enough slack to make turns. If the ball were to break, the trailer would follow in a straight line and prevent the coupler from dragging on the road. Make sure the trailer emergency brake cable or chain is also installed to the tow vehicle frame.
- Ensure the breakaway system lanyard is connected to the tow vehicle and not to the safety chains or ball mount.

NOTE — Make sure the towing vehicle and trailer are in compliance with all state and local laws. Contact your state motor vehicle bureau for laws governing the towing of trailers.

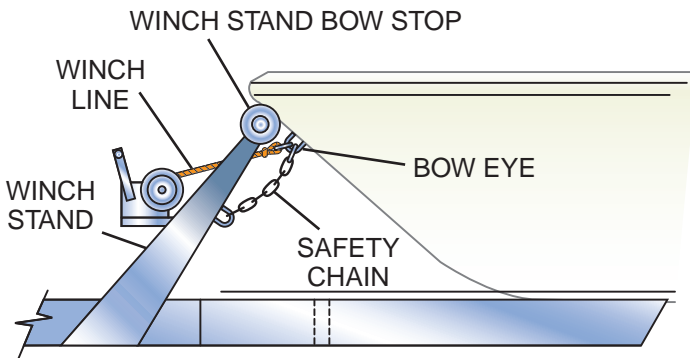

KC-0047C-A

- Once the trailer is secured to the vehicle hitch, stow the trailer jack or lift so that it will not hit the ground.
- Check and correct tire pressure on the tow vehicle and trailer, including the spare tire. Under-inflated tires heat up rapidly and may cause tire damage or failure. The proper tire pressure is listed on the trailer certification plate.
- Check trailer wheel bearings before each trip.
- Secure the stern of the boat to the trailer from the stern eyes.
- Fasten the bow of the boat to the trailer with the bow winch line connected to the bow eye and bow safety chains.
- If travel conditions require, use an additional tie-down strap across the rear of your boat from side to side to further secure the stern.
- Check all strapping material for wear.
- Check that the wiring is properly connected. It should not touch the road but should be loose enough to make turns without disconnecting or damaging the wires.



- Too much or too little tongue weight makes steering difficult and causes the tow vehicle to sway. Put approximately 5% to 10% of boat and trailer weight on the tongue.
- Drive with the vehicle and trailer running lights on.
- Check load distribution to make sure the tow vehicle and trailer are properly balanced front to back and side to side.
- Check that all items are securely fastened on and in the trailer.
- Be sure the trailer jack, tongue support and any attached stabilizers are raised and locked in place.
- Check side-view mirrors and rearview mirrors for good visibility.
- Check routes and restrictions on bridges and tunnels.
- Keep wheel chocks and jack stands on hand.
- Side curtains, backdrop, aft curtains, convertible tops and detachable windshields are not designed to stay on boats at highway speeds. Before towing, take down the convertible top, side curtains, back cover and detachable windshield, if equipped.
- Remove any covers that are not designed to stay on boats at highway speeds.
- Carry a spare tire and wheel for both the trailer and the towing vehicle, along with tools to change them.
- See the *Engine Operator's Manual* for engine-related trailering information. Continuous road shocks may fatigue the boat's steering system.
- Tie outboard motors in place so they will not tilt or turn from road shock.
- On extended trips, carry spare wheel bearings, seals and races.
- While traveling, check the wheel hubs every time you stop. If the hub feels abnormally hot, inspect the bearing before continuing your trip.
- Carry a fire extinguisher in the vehicle.
- Turn carefully while towing a trailer; additional space and distance are needed.

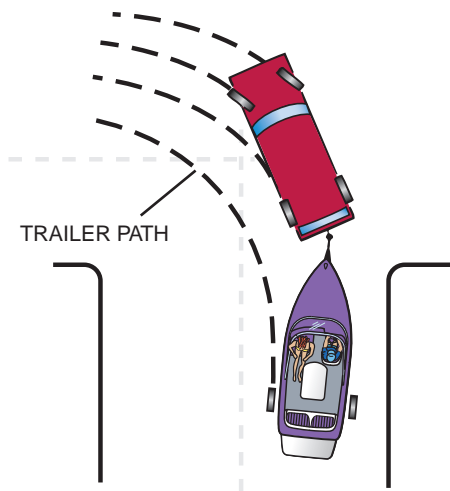

KC-0294C-A



- Drive slowly over railroad tracks or rough roads.
- While trailering the boat from lake to lake, boaters may unknowingly introduce a foreign aquatic species from one lake to the next. Thoroughly clean the boat below the waterline, remove all weeds and algae and drain the bilge and livewells before launching it in a new body of water.

## BACKING UP

If you have never towed a trailer before, take time to practice and become comfortable with backing up the boat and trailer. Situations can arise in traffic, or when launching, that will require you to be able to back up the trailer safely.

Follow these guidelines when backing a trailer:

- Back slowly and make small steering adjustments.
- Turn the car wheels in the direction opposite where you want the trailer to go.
- After the trailer begins moving, turn the car to follow it.
- Have a second person assist you with audible and hand signals.

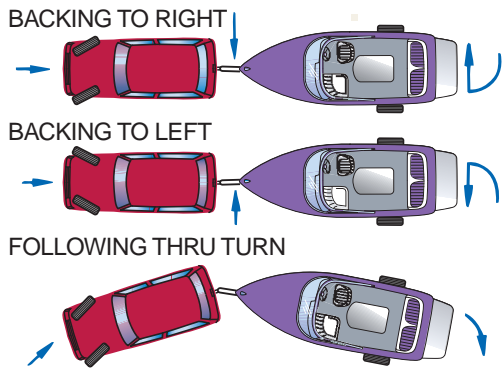

KC-0249C-A

## LAUNCHING

Before launching, inspect the launch ramp for any problems that may hinder launching or make launching unsafe. Ramps can be slick and dangerous to drive or walk on, and may have unseen drop-offs beneath the water that would pose a safety hazard. Always be aware of water conditions and the effects of the wind when launching.

Before launching, inspect the boat and trailer for damage. Do not launch if you detect damage or find that the engine or propeller is not in good operating condition. Have any repairs made before launching.

Use courtesy when preparing the boat for launching by preparing away from the ramp on level ground before proceeding to the launch ramp.



SECTION  
**10** TRAILERING AND LAUNCHING

When launching the boat on the trailer, have two or more people assist you. Since all launches are different, the following procedures are intended as guidelines only:

- Verify that the vehicle's brakes, including the parking brake, are in proper working order.
- Make sure the trailer is securely fastened to the vehicle.
- Remove the boat cover, if equipped.
- Check that the bilge drain plug is in place and all other plugs that allow water to leak into the boat are in place.
- Remove all tie-downs from the boat.
- Attach the bow and stern docking lines.
- Attach boat fenders if necessary.
- Disconnect the trailer's light harness from the car.
- If applicable, trim or tilt the engine/outdrive up to avoid damage.
- Make sure the bow winch and strap are securely locked and fastened.
- Make sure the bow winch safety chains, if equipped, are in place.
- Make sure all required documentation and safety equipment are on board.
- Verify that batteries are fully charged and in good condition.
- Check fuel level; add fuel if necessary.
- Always launch with the help of another person.
- Make sure there is no one on the ramp behind the boat.
- Keep the trailer/vehicle combination as straight as possible and at 90 degrees to the shoreline.
- Back slowly down the ramp until the transom of the boat is a few inches in the water; then stop the vehicle.
- Stop the vehicle and shift into PARK (automatic transmission) or REVERSE (manual transmission). Apply the brakes and/or parking brake. If possible, use wheel blocks.
- Position the mooring lines within reach of the dock.
- Disconnect the bow winch strap and safety chains, if equipped, from the bow eye.
- Manually back the boat clear of and off the trailer into the water and secure to the dock using mooring lines.
- Remove any wheel blocks and release the vehicle brakes. Pull the trailer slowly out of the water, and secure and park in a designated area.
- Board the boat.
- Lower the engine/outdrive, if applicable.
- Run the bilge blowers as required, if equipped.
- See the *Engine Operator's Manual* for starting procedures.
- Remove dock lines from the dock and proceed slowly away from the dock.





## LOADING GUIDELINES

Follow these guidelines while loading the boat onto the trailer:

- When loading the boat on the trailer, have two or more people assist you.
- Stop, turn off the engine and secure it to the dock with dock lines at a position clear from where the trailer will be in the water.
- If applicable, trim or tilt the engine/outdrive up to avoid damage.
- Verify that the vehicle's brakes, including the parking brake, are in proper working order.
- Disconnect the trailer's light harness from the tow vehicle.
- Make sure the trailer is securely fastened to the vehicle.
- Back the trailer slowly down the ramp until it is positioned so that the boat can be loaded.
- Stop the vehicle and shift into PARK (automatic transmission) or REVERSE (manual transmission). Apply the brakes and/or parking brake. If possible, use wheel blocks.
- Position the mooring lines within reach of the dock.
- Manually position the boat onto the trailer using mooring lines. Make sure it is centered on the supports of the trailer.
- Position the bow eye into the bow stop and connect and secure the bow winch strap and safety chains, if equipped, to the bow eye.
- Secure the mooring lines inside the boat.
- Remove any wheel blocks and release the vehicle brakes. Slowly pull the trailer and boat up the ramp.
- Secure the transom to the trailer.
- Prepare for trailering as necessary.

## REPORTING SAFETY DEFECTS

If you believe that your boat trailer has a defect which could cause a crash or could cause injury or death, you should immediately inform the National Highway Traffic Safety Administration (NHTSA) in addition to notifying the trailer manufacturer.

If NHTSA receives similar complaints, it may open an investigation, and if it finds that a safety defect exists in a group of trailers, it may order a recall and remedy campaign. However, NHTSA cannot become involved in individual problems between you, your dealer or the boat manufacturer.

To contact NHTSA, you may call the Vehicle Safety Hotline toll-free at 1-888-327-4236 (TTY: 1-800-424-9153); go to <https://www.nhtsa.gov>; or write to Administrator, NHTSA, 1200 New Jersey Avenue SE, Washington, DC 20590. You can also obtain other information about motor vehicle safety from <https://www.nhtsa.gov>



SECTION

**10**

## TRAILERING AND LAUNCHING

This Page Intentionally Left Blank

# Section 11

## CARE AND MAINTENANCE

This section describes how to take care of and maintain your Tigé boat. Periodic inspection and maintenance of items listed in this section are absolutely necessary.

Winterization of major components and some engine maintenance procedures are best performed by your Tigé dealer. Some maintenance procedures also require special tools which only a dealer may have. Refer to the engine's owner's manual for maintenance information for the engine.

Some maintenance items that can be done by you or your dealer are listed in this section. We suggest that you become familiar with these even if you have your dealer service your boat.

### SAFETY EQUIPMENT

#### LIFE JACKETS

Maintaining life jackets is important to extending their life. Proper cleaning/sanitation will help rid life jackets of sunscreen, mold and mildew that may break down materials over time. When cleaning, be sure to inspect life jackets for wear and tear that might require repair or replacement. Life jackets are often neglected until they are needed. Consult the life jacket's owner's manual or website for more information.

#### Use and Storage

Life jackets that are wet, dirty, or stored in humid conditions can deteriorate quickly. Sunscreen products and body oils can accelerate deterioration. The following tips will help to extend the life of life jackets:

- After use, air-dry jackets out of direct sunlight and away from tree sap. If on the boat, choose a well-ventilated space.
- If you can't air-dry outside, place the jackets on hangers, space at least 6 inches apart, and ventilate with an oscillating fan.
- If dirty (sand or stains) or used in salt water, rinse jackets with plenty of fresh water.
- If stained from sunscreen, foods, or other sources, clean as soon as possible.
- Clean life jackets at least annually.

**Do Not:**

- Use chlorine bleach directly on a jacket, as it can break down fabrics and interior foam.
- Clean jackets with industrial cleaning agents or something like gasoline, paint thinner or acetone. They can dissolve the foam that makes the device functional and weaken the exterior fabric.
- Machine-wash, dry-clean or use strong detergents or degreasers.
- Dry jackets with a direct heat source or clothes dryer.
- Bend life jackets or place heavy objects on top of them, as this can cause crushing and damage performance.

**Cleaning Life Jackets:**

Clean the life jackets annually at the end of the season. To clean:

- Fill a bucket with cool water and about two tablespoons of mild liquid laundry detergent.
- Lay a tarp on the ground and place the life jackets, with all straps and hardware unfastened, on the tarp.
- Treat stains with a laundry pre-wash stain remover, work it in with a soft brush and allow it to work for 5 minutes.
- Scrub all surfaces of the jacket using the detergent solution and a soft brush.
- If the jacket has mold or mildew, move it to an outside area and brush away any visible spores before wetting the fabric. Scrub as suggested but add 1/4 cup of oxygen-based bleach to the cleaning solution to help remove dark stains.
- Rinse well using plenty of clean water.
- Hang the jacket to drip-dry out of direct sunlight.
- Place the jackets on hangers, space at least 6 inches apart, and ventilate with an oscillating fan until completely dry.
- Store life jackets in a dry, cool, dark place.



## GENERAL MAINTENANCE

1. Read *Engine Owner's Manual* carefully and completely.
2. Check and make sure all drain plugs are installed correctly every time you use your boat.
3. Check the fuel system for leaks every time you use your boat.
4. **DO NOT** start your engine if you smell gasoline or an odor is present. Gasoline fumes are highly explosive. Before starting your engine, always operate the blower for at least four minutes or open the engine cover and inspect the engine compartment for gasoline fumes. Run your blower when operating at slow speeds. If fuel vapors are present, **DO NOT** start the engine. Check all hoses and fittings to determine the source of the vapor. Make the necessary repairs or take the boat to a qualified service technician to eliminate the fuel vapor.



### **WARNING**

***Gasoline Vapors Can Explode: Before starting engine, run blower four minutes and check engine compartment bilge for gasoline vapors. Run the blower below cruising speed.***

5. When servicing the ignition switch or any wiring, disconnect the battery cables from the battery.
6. Check for water circulation when the engine is running.

Exhaust should contain steady flow of water. In closed cooling systems, make sure the coolant in the cooling system is at the proper level.



## INTERIOR

**If your boat has Cool Touch/Chil Cool™ Technology, please refer to the Cool Touch Vinyl Interior Instructions.**

The interior fabric of your Tigé boat is designed to take the tough punishment of the elements and usage of an active boater. Keep sharp objects away from the interior to prevent cuts or damage to your interior.

The interior of your Tigé boat can be cleaned easily, over and over, without showing signs of wear. Certain ingredients in products can contribute to staining of your interior, such as sunscreens. Some of these ingredients are:

- Aminobenzoic acids—e.g. PABA
- Hydroxy benzophenones—e.g. Oxybenzone
- P-methoxycinnamic acid
- Octylmethoxycinnamate

This list is not inclusive, but does represent a large selection of sunscreens which are known to stain vinyls. Almost any sunscreen with a high percentage (2% or more) of active ingredients can stain.

**The interior manufacturer or Tigé Boats warranties do not cover staining from sunscreens.**

Special care should be taken to prevent dark-colored rubber products from coming in contact with your interior upholstery. Regular vacuuming and general cleaning of carpets is recommended. Washing with warm soap and water is recommended for cleaning hard-to-remove spots and dirt. Under no circumstances should any solvents normally associated with the dry cleaning of apparel be used on the interior carpet of your Tigé.

### NOTICE

*It is extremely important to clean the stained area as quickly as possible, making sure the recommended cleaning steps are followed in order.*

## CARE AND CLEANING OF INTERIOR—COOL TOUCH / CHIL COOL™ VINYL

On Cool Touch/Chil Cool™ vinyl use only mild non-bleach soap and water. DO NOT use these or similar cleaners: 409®, 303®, Babe's®, Boat Bling®, Star brite®, Meguiar's® or Fantastik®. They are very harmful to your upholstery and will damage its surface and cooling properties. Failure to care for your vinyl properly or use of improper cleaners will void your warranty and damage your vinyl.



## Cool Touch/Chil Cool™ vinyl upholstery cleaning and care instructions:

- A** – Mix a solution 30:1, (30 parts warm water and 1 part mild non-bleach liquid dish soap).
- B** – Apply and rub with a soft, damp cloth.
- C** – Rinse with clean, warm water and wipe dry.

## CARE AND CLEANING OF INTERIOR—STANDARD VINYL

Remove ordinary dirt and light smudges with a solution of mild soap and warm water. Pay special attention to crevices. Dry it with a soft, lint-free cloth or towel. Always allow upholstery to dry completely. Cover the boat when not in use, allowing for adequate venting. Never use a pressure washer, as it may damage the surface of the upholstery. For more difficult stains, use a stronger detergent. Follow the detergent manufacturer's instructions closely. All cleaning methods must be followed with a thorough rinse with clean warm water.

### Step-by-step cleaning instructions:

- A** – Medium-soft brush, warm soapy water. Rinse/dry.
- B** – Vinyl Finish Vinyl Cleaner®. Rinse/dry.
- C** – One teaspoon of ammonia, ¼ cup of hydrogen peroxide and ¾ cup of water. Rinse/dry.
- D** – Wipe or scrape off excess. (Chill gum with ice.)
- E** – Hemisphere Ink Remover. Rinse/dry.

TYPES OF STAIN	STEP 1	STEP 2	STEP 3
General Care	A	B	-
<b>FOODS</b>			
Chewing Gum	D	A	-
Chocolate, Coffee, Tea	B	-	-
Grape Juice	A	C	-
Ketchup	A	B	-
Olive Oil	A	-	-
Yellow Mustard	A	B	C
<b>MISCELLANEOUS</b>			
Ballpoint Ink	E	B	A
Bird Droppings	A	B	-
Blood	A	C	-



MISCELLANEOUS			
Dirt Buildup	A	B	-
Grease	D	B	-
Hair Oil Tonic	A	-	-
Household Soil	A	B	-
Latex Paint	A	B	-
Lipstick	A	B	-
Mildew or Wet Leaves	C	B	A
Motor Oil	B	-	-
Oil Base Paint	D	B	-
Oily Spot	A	B	-
Permanent Marker	E	B	C
Spray Paint	B	-	-
Suntan Lotion	A	B	-
Tar / Asphalt	D	B	-
Urine	A	C	-

## CLEANER RECOMMENDATIONS

D0s	DON'Ts
Vinyl Finish Vinyl Cleaner®	Fantastik®
Dish Soap	Formula 409®
Dawn®	Murphy's® Oil Soap
Ivory®	Simple Green®
303 Aerospace Protectant	Armor All®
	Sun-of-a-Gun®
	Bleach/Baking Soda
	Turtle® Wax/Tar Remover





## NON-SKID FLOORING CLEANING INSTRUCTIONS

- a. **To clean dirt, footprints, etc.**, use an all-purpose cleaner, such as Formula 409, and warm water along with a medium-bristled deck brush. Put the cleaner in warm water. Take a medium-bristled brush and dunk into the soapy water. Work around on non-skid flooring until dirt or other substance comes up. Rinse with water. Repeat if necessary.
- b. **To remove suntan lotion**, use the all-purpose cleaner alone with a medium-bristled deck brush. Put small amounts of the all-purpose cleaner on oil. Dip medium-bristled deck brush in warm water and work around until oil is out. Rinse with water. Repeat if necessary
- c. **To remove fish blood**, use 1 cup bleach to 1 gallon of warm water and soft-bristled boat brush. Mix bleach and water. Take soft-bristled brush and dunk in water/bleach mixture. In a circular motion clean non-skid flooring until fish blood is up. Rinse with water. Repeat if necessary. If not effective, see item D.
- d. **To remove rust stains**, use a capful of MaryKate® On & Off Hull & Bottom Cleaner for fiberglass. Apply on the rust stain and allow to soak for 3-5 minutes. If necessary, use latex/nitrile gloves to massage the cleaner into the brush or embossed texture of the non-skid flooring. Rinse with water. Repeat if necessary; the rust stain will eventually be removed.

With MaryKate Hull Cleaner, be careful to avoid getting this solvent on the sides of the flooring pad; it could damage the lamination or PSA.

### DO NOT USE:

- Mineral spirits
- MaryKate Hull Cleaner (as a general cleaner, okay for Item D application ONLY)
- Acetone (if it must be used, avoid the adhesives as best as possible)
- Bleach (if used, dilute with 1 cup bleach to 1 gallon of water)



### **WARNING**

***Leaking fuel is a fire and explosion hazard. Inspect system regularly. Examine fuel system for leaks or corrosion at least annually.***

## DARK STOWAGE AREAS

When a boat is stored completely covered or in a dark building, the vinyl will darken or become “dingy” looking. If this happens, simply place the boat in direct sunlight for a few hours and the vinyl will brighten up.



## BILGE PUMP AND BILGE AREA

Check your bilge pump often to make sure it is functioning properly. The BILGE switch can be used to test the bilge pump, by listening to hear that the pump is operating. It may not pump water unless water is present. The bilge pump is located in the bilge area. Keep it from getting clogged by removing any debris you find in the bilge area. Debris can also block the pump float from functioning or make it operate continuously. Make sure no debris is blocking the bilge pump float.

Wash the bilge with a good biodegradable household detergent or a bilge cleaner available at your Tigé dealer or a marine supply store. Rinse with water while your bilge pump is running. If your pump seems too slow, remove the top of the pump from the base and check the impeller to make sure there is no debris inside. See your dealer if there is still a problem or you suspect a problem with the pump.

### IMPORTANT

**DO NOT discharge oil or cleaners into the water. Bilge pumps and bilge pumping systems are not designed for damage control. Check the function of all bilge pumps at regular intervals. Continuous operation of the bilge can mean a leak or a drain plug installed incorrectly. Make sure all drain plugs are installed. See your Tigé dealer if you have any questions.**

## EXTERIOR

Use quality boat care products when protecting the exterior of your Tigé boat. The exterior of your boat is as important as protecting the engine. A little effort today will keep your boat looking good in the future and will show the pride every time you use your boat.



### WARNING

***Fire/Explosion/Asphyxiation Hazard: Cleaning agents and paint ingredients can be flammable and/or explosive, or dangerous to inhale. Make sure ventilation is adequate, wear proper personal protection and dispose of tags properly ashore.***

***Vapors from flammable solvents can cause fire, explosion or asphyxiation, resulting in death or serious injury. Keep open flame or spark away from work area. DO NOT paint unless in a well-ventilated area.***



### WARNING

***Slippery Surface Hazard: Cleaning craft surfaces can generate slippery conditions which can result in death or serious injury. Use caution when cleaning with detergents and rinse thoroughly.***



## GELCOAT MAINTENANCE

Regular maintenance will keep your exterior surfaces in good condition. Exposure to the sun, sand, sap or staining properties from trees and minerals in the water affect your boat's finish.

To help maintain the shine of your boat, wash the hull with a mild biodegradable, non-abrasive detergent after each use to help to remove any debris and waterborne materials. Use a soft sponge or towel and dry with a chamois cloth to prevent water spots. Give your boat a fresh water wash after saltwater use. Cover if possible to keep your boat looking its best. Never place a non-breathable cover on a boat that is still wet. Store in a dry, covered area.

Remove any unintentional fuel or oil spills from the gel-coated surfaces as quickly as possible.

Wax the hull sides and deck at least twice a year with a high-performance marine wax. Waxes and polishes can be obtained from your Tigé dealer or a marine supply store. Always follow the directions of the manufacturer of these products before you use them.

In certain areas, sudden changes in temperature can affect gel coat. When planning on moving your boat from outdoors to a heated location, allow the change of temperature to be gradual. Heat the location after the boat is brought inside to allow the boat to change temperature slowly as the location is heated. Also, if you are planning on moving your boat from a warmer area to a colder one, wait for the outside temperature to be closer to the warmer area's temperature or allow the warmer area and the boat to cool down before moving your boat.

If your boat's gel coat develops a chalky look over a period of time due to exposure to sun, there are gel coat buffing and polishing compounds available from your Tigé dealer or a marine supply store. **DO NOT** use common household scouring pads or powders.

Remove any small scratches or scuffs using a fine rubbing compound. For any major repairs, consult your Tigé dealer.

The hull bottom is also an important area to keep clean since buildup of water scum and algae will reduce the boat's efficiency. If you leave your boat in the water, compounds to remove algae buildup on your hull are available. Use care when choosing these products since some can be caustic. Pay special attention to the cautions on the labels of these coatings. Ask your Tigé dealer for advice on which products work best in your area.



## Deck and Hull

The finish on your Tigé boat is known as gel coat. Our gel coat and lamination processes are among the finest available. Even though we take all the precautions during manufacturing, the finish on your boat is susceptible to the elements and many types of water conditions.

### Cleaning Deck and Hull

A multipurpose boat soap<sup>1</sup> should be used to clean exterior fiberglass/gelcoat surfaces on your Tigé boat after each use. This product, depending upon the ratio mixed, is designed to clean anything from dirty hulls and decks to greasy engines. Always rinse and wipe off the finish with a damp towel or chamois.

A fiberglass restorer/wax\* should be used to remove heavy oxidation, rust and exhaust stains. This product will not only restore the look but will also leave a wax protection on the cleaned surface.

### Deck and Hull Care

Paste wax\* will help protect against UV light damage. A coat should be applied at the beginning, middle and end of the boating season.

To extend the life of your gel coat finish, use a Tigé marine mooring cover to cover the top deck of the boat for maximum protection. If your boat is to be stored where the sun is constantly on the side or transom of the boat, you should consider protecting those surfaces.

Tonneau covers will supply adequate short-term protection to the interior, but will not protect the gelcoat finish.

### Stainless Steel and Chrome

Stainless steel is highly resistant to marine environments, but is still capable of rusting. Signs of rust and corrosion when left untreated can result in permanent damage. You can keep your stainless steel looking new by cleaning monthly with a good quality stainless steel cleaner or polish. Clean and polish in the direction of the grain or finish.

Clean and wax metal prior to extended storage. In salt water or other harsh environments, clean and wax more often. High-quality stainless steel cleaners and conditioners are commercially available. Rinse with fresh water and wipe dry with towel or chamois after each use.

---

<sup>1</sup> 3M and your Tigé dealer carry a complete line of fiberglass care products.



### Cleaning Stainless Steel

If rust or corrosion does appear use a good metal cleaner/polish immediately to protect from permanent damage. DO NOT use steel wool or other coarse abrasives, or clean with citrus cleaners, acids or bleach. DO NOT use cleaners that are not for use on stainless steel, such as glass, tile or counter cleaners. These types of cleaners can damage the surface permanently. Apply metal or automotive wax, such as GEMLUX® Cleaning Wax, after cleaning for additional protection and to maintain the finish. Always test any product in an inconspicuous area before applying to the complete surface.

If you have to replace hardware or fasteners, make sure the replacement components are made of the correct materials. See your Tigé dealer if you have any questions.

**DO NOT store soiled rags onboard. Store or dispose of rags properly ashore.**

### NOTICE

*Use caution in cleaning around stitching, wood or other decorative trim since solvents could seriously damage these materials.*

## PROPELLER



### WARNING

*Cut Hazard: A propeller can be sharp and can cause death or serious injury. Wear a pair of protective gloves when handling any propeller. Prevent accidental starting of the engine by:*

- *Removing key from the ignition.*
- *Removing emergency stop switch clip from the switch.*

**DO NOT reuse the nylon locknut or the cotter pin, or use a damaged propeller. A damaged propeller can damage your engine and boat.**

**To remove:**

1. Remove the cotter pin from the propeller shaft and discard.
2. Wedge a piece of 1" x 4" wood between the propeller blade and the port side of the strut and rudder.
3. Remove the nylon locknut and discard.

Use a propeller puller to remove the propeller and then remove the key from the keyway. Make sure the keyway in the propeller and on the shaft are free of any damage.



See your Tigé dealer for service to ensure the prop has been removed properly and that the shaft seal has not been damaged.

**To install:**

Look at the keyway on the shaft and in the propeller and make sure the key slides freely in the propeller keyway and shaft keyway. If the key has burrs, remove them by filing the flat sides or replace the key. **DO NOT** file the key beyond its normal shape or size.

1. Rotate the shaft until the keyway is up.
2. Place the key in the shaft keyway. Rotate the propeller so the keyway in the propeller is aligned with the keyway on the shaft. The propeller will only slip on in one direction. Once everything is aligned, push the propeller solidly onto the shaft and make sure the propeller is seated.
3. Wedge a piece of 1" x 4" wood between the propeller blade and the starboard side of the strut and rudder.
4. Install a new nylon locknut and torque the nut to maximum of 30 ft-lbs (40.7 N·m).
5. Install a new cotter pin and bend the retaining ends of the cotter pin in opposite directions.

**RUDDER**

If you experience trouble turning your steering wheel then it could be caused by the rudder having issues turning. If your rudder port is equipped with a zerk fitting you are required to use Lubriplate Synxtreme FG-2 grease or an equivalent food grease.

The use of any petroleum based product will pollute the environment and lead to failure of the part. **DO NOT USE PETROLEUM BASED GREASE.**

**SALTWATER CORROSION**

Rinse your boat hull and deck with fresh water and wash immediately after using your boat in salt water. If your boat is used primarily in salt water, wax the hull monthly and apply corrosion inhibitor to all hardware. See the *Engine Operator's Manual* for the flushing procedure.

Flushing the freshwater engine cooling system is recommended when the engine has been used in salt, polluted or brackish waters. Flush the entire engine cooling system with fresh water for at least 5 minutes after use in these waters. Consult your local marine dealer for suitable flushing equipment.



## BATTERIES



### WARNING

*Electrical Shock Hazard: Always disconnect the batteries before performing maintenance on the DC electrical system. Electrical shock may occur if the batteries are not disconnected during maintenance on the DC electrical system.*



### WARNING

*Personal Injury Hazard: Always wear gloves and protective eyewear when working on and around the batteries. The batteries contain an acid called electrolyte. Avoid causing damage that could spill electrolyte into the bilge when servicing the batteries. Avoid getting salt water in or on the battery. Either condition can create a poisonous gas that is harmful if inhaled. Always disconnect the batteries before cleaning.*



### CAUTION

*Personal Injury Hazard: Never allow a tool to bridge across the battery terminals. Injury can result if the terminals are accidentally bridged with a tool or other conductor.*

Today's boats can be loaded with electronics that all run off the boat's battery. Because of this, many boats will have two or more batteries: one for starting and running the engine, and one for electronics, commonly referred to as the house battery. One advantage is that the starting battery will not be drawn down when using electronics with the engine off, such as with a stereo. Another advantage is if the starting battery has lost capacity because of age, the battery switch has a 1+2 (Both) position that parallels both batteries for emergency starting.

Marine batteries generally come in two types: starting and deep-cycle. Starting batteries are similar to car batteries, can supply lots of current for a short period of time and are used for starting the engine. Starting batteries should be recharged almost immediately and do not tolerate deep discharges. Deep-cycle batteries are designed for repeated discharging and recharging cycles without damage. They are used as the house battery on boats with higher DC power requirements.

All batteries have one thing in common — they run for a while, need recharging and require an eventual replacement as the capacity fades. Most marine batteries are sealed and require no maintenance other than keeping them at a full state of charge and diligently cleaning corrosion from the terminals. To maintain long life, deep-cycle batteries should not be discharged more than 50% before they are recharged.

Most marine batteries are flooded, sealed lead-acid, but there are several different battery types/chemistries that could be used. You must use caution when charging or replacing the batteries; replace batteries with the exact same type, group and capacity. If your boat is not equipped with an onboard battery charger, use a smart charger suitable to your battery type/chemistry.

**CAUTION**

**Burst Hazard: Never use an automotive type (lead-acid) battery charger to charge a gel cell type battery. Doing so will cause damage to both the charger and battery and can cause the battery to burst. Use a battery charger specifically designed to charge gel cell type batteries.**

Always turn off the battery switch (if equipped) or disconnect the negative battery cable before servicing the electrical system.

**NOTICE**

The following information applies to lead-acid batteries. If you replace the batteries with batteries using different chemistry such as Li-Ion, you must follow the battery manufacturer's instructions for inspection, maintenance and charging.

Refer to the OEM information for operation details.

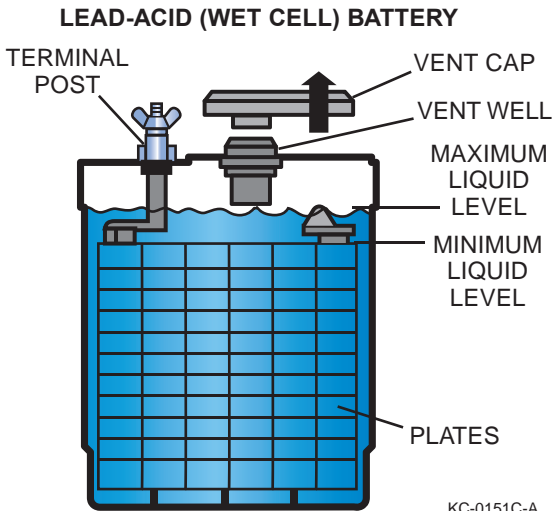





When you install a battery:

- Make sure the battery terminals are clean.
- Be certain to use correct polarity when you connect the battery cables to the battery.
- Make sure the cable connections are tight.
- Always shut down the engine before removing or attaching battery cables and never run the engine with the battery cables disconnected.
- Always remove the negative (-) cable first. Always attach the negative (-) cable last.

Check the battery frequently for signs of corrosion. If corrosion is evident, clean the terminal posts with a baking soda and water solution and a wire brush. Disconnect the battery terminals before cleaning.

**WARNING**

***Burn Hazard: Lead-acid battery fluid can cause severe burns.***

Check the fluid levels in the cells.

**NOTICE**

***Some batteries are sealed and cannot be filled. A level of approximately 1/4 to 1/2 in. (6 to 13 mm) above the plates is sufficient. If needed, fill with distilled water; do not overfill.***

During extended periods of non-use, batteries will self-discharge and should be recharged. Before recharging, disconnect the battery terminals and remove the battery from the boat. Recharge the battery according to the directions enclosed with the battery and battery charger. When installing the battery in the boat, make sure the battery is secured in the battery box, the terminals are tight and all protective covers are in place.

**WARNING**

***Fire/Explosion Hazard: Hydrogen gases produced by a lead-acid battery while it is charging, or the engine is running, can cause a fire and/or an explosion.***



## TRANSMISSION OIL LEVEL INSPECTION

Refer to engine manual or your authorized Tigé dealer.

Check the oil with the boat level and the engine off.

Remove the oil level dipstick. The oil level should be between the “FULL LEVEL” and the “LOW LEVEL” indicator marks on the dipstick.

Verify the oil level with the gauge fully inserted into the transmission housing. **DO NOT overfill.** Use fresh recommended fluid only. To add or fill, use the dipstick opening. Refer to the transmission owner’s manual for type of fluid, changing fluid intervals and more detailed information.

## STEERING SYSTEM

The steering system is the primary link for boat control and must be inspected and maintained regularly. Do not operate the boat if you suspect the steering system is malfunctioning. The following basic inspection and maintenance procedures may not apply to your steering system. For additional information contact your dealer.

 **WARNING** *Control Hazard: Improper maintenance of steering system is hazardous and can cause death or serious injury from sudden loss of control. Ensure all steering reservoirs, connections, hardware, cables and grease fittings are regularly inspected and maintained. If any steering problems are noticed, do not operate the boat and contact your dealer immediately for service assistance.*

- The rack and pinion helm gear box is typically a sealed and lubricated unit, which requires no lubrication. Contact your dealer for specific information on your helm unit.
- The connections at both the helm and rudder arm end of the steering cable must be checked frequently for tightness.
- Turn the engine OFF and remove the ignition key and engine emergency stop switch lanyard from the switch. Make sure the throttle lever is in NEUTRAL. Allow the engine to cool before servicing.
- Inspect the entire steering cable for kinks and wear on the outer jacket. Turn the steering wheel lock-to-lock and check rudder movement to verify proper operation. If the cable is damaged, binds or does not have smooth movement, contact your dealer for service.



The steering cable and system must be lubricated periodically to ensure smooth operation. To clean and lubricate the cable:

- Turn the helm to a position that extends the steering cable out of the outer jacket, exposing the cable end at the rudder arm end.
- Use solvent to clean the old lubricant from the cable end, rudder arm and rudder shaft.
- Spread a generous amount of waterproof marine all-purpose grease over the cable end. Work the helm back and forth and reapply grease as necessary.
- If applicable, use a flexible hose grease gun and apply waterproof marine grease to the cable and rudder grease fittings. Clean up any excess grease.
- Rotate the helm back and forth several times to work the lubricant in.

The rudder arm is connected to the rudder shaft. The rudder shaft is lubricated by the rudder stuffing box. The rudder stuffing box may be sealed or a grease fitting may be incorporated to allow lubrication during maintenance. To lubricate the rudder stuffing box when applicable, connect a grease gun to the fitting and apply grease using light pressure until a slight resistance is felt. Use only a marine grade, waterproof grease.

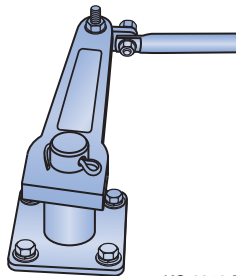

KC-0250-B

Check the rudder frequently for damage and tightness. If the rudder is damaged or requires service, contact your dealer for service.



## SEA STRAINER MAINTENANCE

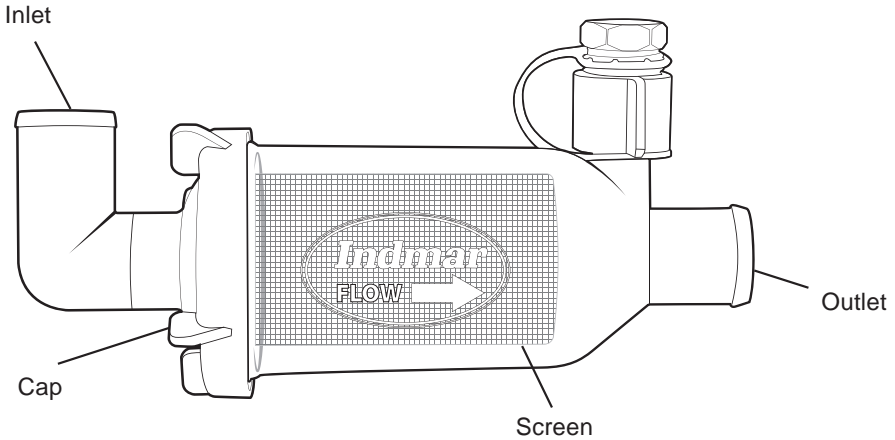

The sea strainer is designed to prevent weeds and other debris that enter the cooling system from entering the engine and restricting water flow. Check the sea strainer screen regularly for debris and clean as necessary.

### WARNING



***Be sure to close the raw water inlet sea cock before servicing the sea strainer. Do not remove the sea strainer inlet cap to remove debris while the boat is in the water unless the raw water sea cock is closed to prevent raw water from entering the boat.***

1. Close the raw water inlet sea cock.
2. Remove the inlet cap by rotating it in a counterclockwise direction.
3. Remove the screen from the sea strainer for cleaning.
4. Install the screen in the sea strainer.
5. Install the inlet cap, making sure to not damage the sealing O-ring.
6. Hand-tighten the inlet cap. Do not over-tighten.
7. Open the raw water inlet sea cock and check for leaks.



## FLUSHING THE ENGINE

### WARNING



*Be sure to close the raw water inlet sea cock before flushing the engine. Do not remove the sea strainer flushing port cap unless the raw water inlet sea cock is closed to prevent raw water from entering the boat.*

To flush the engine with fresh water:

1. Close the raw water sea cock.
2. Remove the flushing plug from the sea strainer flushing port cap.

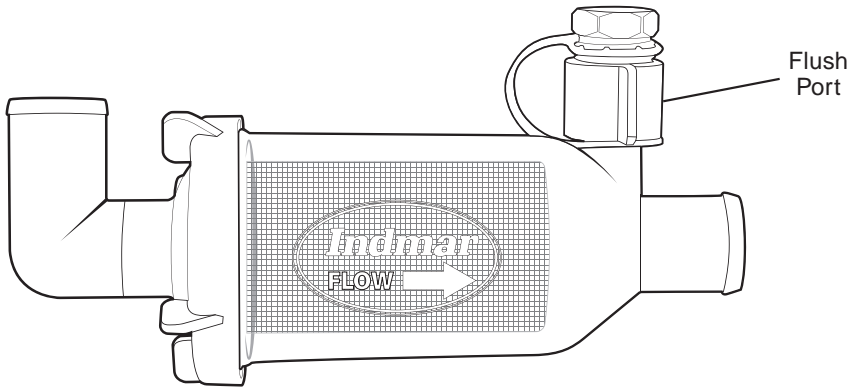

3. Attach a standard water hose to the flushing port.
4. Turn on the water supply between  $\frac{1}{4}$  and  $\frac{1}{2}$  pressure.
5. Start the engine and let it idle with the transmission in NEUTRAL.
6. Turn the water supply to full pressure.
7. Increase the engine RPM to 1200 RPM maximum and let it run 10 to 15 minutes to thoroughly flush the raw water portion of the cooling system.

**NOTICE**

*If you plan to store the boat for more than three months in either a humid environment, extreme temperatures or outdoors, “fog” the engine with a corrosion-preventing fogging oil according to the propulsion system manufacturer’s recommendations. See the Engine Operator’s Manual for more information.*

8. Return the engine RPM to idle.
9. Reduce the water supply pressure to  $\frac{1}{4}$  to  $\frac{1}{2}$  pressure.
10. Turn off the engine.
11. Turn off the water supply.
12. Remove the water supply hose from the flushing port.
13. Install the flushing port cap.
14. Open the raw water inlet sea cock and check for leaks.

**UNSCHEDULED MAINTENANCE**

A problem with any electrical or mechanical equipment can occur anytime. Be aware of a malfunction if one occurs, or if you suspect a problem. Have the problem serviced immediately by your Tigé dealer.

**ENGINE / PROPULSION / COOLING SYSTEM**

If a problem occurs with your engine, propulsion unit or the cooling system between the scheduled maintenance cycle, immediately notify your Tigé dealer to have the problem resolved. DO NOT allow a problem to go unattended.

**ELECTRICAL SYSTEM**

Have your Tigé dealer repair all electrical problems. Electrical problems must be treated seriously and repaired immediately. Whenever checking for electrical problems, use extreme caution. Fuel and fumes are extremely flammable and explosive.

**WARNING**

*Fire or Explosion Hazard: An AC/DC can create sparks. In the presence of explosive gases, fire or explosion can occur. Check for explosive gases or run the blower.*

**DO NOT work on an energized system. Turn the battery disconnect switch OFF.**



## WINTERIZATION AND STORAGE PREPARATION

The following procedures will help prevent damage to the boat:

- While the boat is still in the water, add the proper amount of fuel stabilizer/conditioner according to the engine manufacturer's recommendations. If the boat contains fuel with ethanol, pump-out as much as possible before removing the boat from the water. Operate the boat for at least 15 minutes to be sure that the treated fuel has reached the engine.

### NOTICE

*If you plan to store the boat for more than three months in either a humid environment, extreme temperatures or outdoors, "fog" the engine with a corrosion-preventing fogging oil according to the propulsion system manufacturer's recommendations. See the Engine Operator's Manual for more information.*

- Once the boat is removed from the water, remove the bilge drain plug immediately. Store the drain plug in a plastic bag and tape it to the throttle control lever for easy accessibility the next time you use the boat.
- Inspect all sacrificial corrosion protection anodes for excessive wear and replace as necessary.
- Check all thru-hull fittings and other fasteners for tightness and leakage.
- Thoroughly clean the hull, deck and interior of the boat as soon as you remove it from the water; marine growth is easier to remove when it is wet.
- Always allow all boat compartments to air dry for a couple of days to prevent mildew from trapped moisture. If you use shrink wrap, always allow for ventilation to prevent mildew from trapped moisture.
- Apply a coat of wax to the entire surface of the boat and rust inhibitor on all metal parts.
- Clean all traces of dirt, oil, grime and grease from the engine and bilge.
- After washing, raise the bow of the boat high to allow as much water as possible to drain while performing other storage preparations.
- Touch up areas where paint has been removed.
- Prepare the engine for storage according to the *Engine Operator's Manual*. Flush the engine cooling system with clean water and/or a nontoxic antifreeze mixture approved for marine use. Never exceed the maximum engine rpm for flushing recommended as stated in the manual.
- Perform all scheduled maintenance for the engine and boat equipment. See the *Engine Operator's Manual* and all equipment manufacturer's information for periodic and annual maintenance procedures.



- Open all water drains and seacocks, and thoroughly drain all ballast tanks (if equipped) and water lines. Manually disconnect any lines that may have residual water trapped.
- Turn off all electrical switches and breakers.
- Remove all batteries from the boat. Clean, fully charge and store the batteries in an area outside the boat not subject to freezing temperatures. Never store batteries close to heat, sparks or open flames.
- Thoroughly drain the interior heater core and lines (if equipped). Manually disconnect any lines that may have residual water trapped. See the *Heater Operator's Manual* for specific storage information.
- Use nontoxic antifreeze approved for marine use to prevent freeze damage in the ballast tanks and lines. Consult your local marina or certified marine technician for recommendations for your system.
- Clean all interior upholstery, furniture, appliances, etc.
- Pest/rodent repellents may help prevent damage to the boat during storage.



# Section 12

## TROUBLESHOOTING AND SERVICE REQUIREMENTS

The following chart will assist you in finding and correcting minor problems with your Tigé boat. Refer to your engine owner's manual for more detailed information concerning a problem starting, shifting or operating the engine. Some problems may require the skills of a trained technician and special service tools. Contact your Tigé dealer for assistance.

ENGINE SYMPTOM	POSSIBLE CAUSE
Engine will not crank	Ignition safety switch not in place. Install ignition safety switch.  Battery disconnect switch located in engine compartment is off.  Turn switch <b>ON</b> .  Circuit breaker is tripped. Run fingers over breaker face and reset any tripped circuit breakers.  Bad starter connections. Check connections and tighten. If starter solenoid clicks when attempting to start engine, check battery connections. If condition persists, contact your Tigé dealer.  Engine circuit breaker open. Make sure breaker is in operating position.  Faulty ignition switch or engine problem. See your Tigé dealer.  Shift position not in <b>NEUTRAL</b> . Make sure shifter is <b>NEUTRAL</b> .  Starting procedure not followed.
Low starter speed.  Engine cranks but will not start.	Weak or bad battery. See your Tigé dealer.  Fuel level low or empty. Add fuel.  Contaminated fuel. See your Tigé dealer.



ENGINE SYMPTOM	POSSIBLE CAUSE
Engine runs erratically	Contaminated fuel. See your Tigé dealer.
Engine vibrates	Propeller damaged. Check for bent, broken or damaged propeller, misaligned propeller shaft, or weeds on propeller.
Engine runs but boat makes little or no progress	Fouled or damaged propeller. Check for weeds on propeller, bent or broken propeller, or contaminated fuel. See your Tigé dealer.
Performance loss	Throttle not fully open. Make sure throttle opens fully at engines. Improper fuel. Fill tank with correct fuel.
Engine overheating	Turn off engine immediately. Contact your Tigé dealer. Boat overloaded. Reduce load or distribute boat load evenly. Improper propeller selection. See your Tigé dealer. Excessive bilge water. Check for excessive water. Drain bilge. Boat hull buildup or blocked water pick-up. Clean if marine growth is present. Saltwater Flush Kit shut-off valve (if equipped), or water pickup seacock (seacock applies to all models sold in Canada), is <b>CLOSED</b> . Open shut-off valve or seacock (handle in-line <b>[OPEN]</b> with hose, not perpendicular <b>[CLOSED]</b> )
ELECTRICAL SYMPTOM	POSSIBLE CAUSE
Electrical problem	Battery disconnect switch located in engine compartment is off. Turn switch <b>ON</b> . Circuit breaker is tripped. Run fingers over breaker face and reset any tripped circuit breakers. Loose wiring connection. Check connections. Defective switch or gauge. See your Tigé dealer. Dim or no lights, circuit breaker tripped or in <b>OFF</b> position. Check breaker. Battery discharged. Charge battery.



STEERING SYMPTOM	POSSIBLE CAUSE
Steering problems	Corroded steering cable or worn rudder. See your Tigé dealer.
THROTTLE/SHIFTING SYMPTOM	POSSIBLE CAUSE
Throttle/shifting problems.	Low transmission fluid level. Check level. Corroded cables, defective throttle return spring or sticking transmission shift lever. See your Tigé dealer.



# SECTION 12 TROUBLESHOOTING AND SERVICE

## 20-HOUR SERVICE REQUIREMENTS

This service must be performed to keep warranty active. Engine oil and filter must be changed every 50 hours. Please see your dealer.

TIGÉ MAINTENANCE SCHEDULE	DAILY	WEEKLY	REGULAR	ANNUAL	EVERY 2 YEARS	20-HRS.
Smell bilge area for fuel vapors	✓	✓	✓	✓		✓
Check and tighten all steering system bolts and connections						✓
Check rudder, tiller arm bolt and safety setscrew						✓
Lubricate rudder stuffing box and steering support tube						✓
Lubricate cables						✓
Replace cables	If stiffness continues after lubricating					
Check bilge pump operation	✓	✓	✓			✓
Check blower operation	✓	✓	✓			✓
Inspect shaft seal			✓			✓
Check shaft alignment/ensure it is within 0.003"						✓
Check and tighten motor mounts						✓
Tighten pylon and tower mounting bolts	✓	✓	✓			✓
Tighten all hardware and fasteners						✓
Change engine oil and filter						✓
Change transmission fluid						✓
Change engine coolant					✓	



TIGÉ MAINTENANCE SCHEDULE	DAILY	WEEKLY	REGULAR	ANNUAL	EVERY 2 YEARS	20-HRS.
Check engine oil	✓					
Check transmission		✓				
Check water pickups for debris or marine growth		✓				
If equipped with a strainer, check and clean		✓				
If operated in salt water, flush engine/cooling system and boat	✓			✓		
<b>IF PROPELLER STRIKES AN OBJECT, INSPECT DRIVE TRAIN IMMEDIATELY!</b>						

## 70-HOUR SERVICE REQUIREMENTS

This service must be performed to keep warranty active. Engine oil and filter must be changed every 50 hours. Please see your dealer.

TIGÉ MAINTENANCE SCHEDULE	DAILY	WEEKLY	REGULAR	ANNUAL	EVERY 2 YEARS	70-HRS.
Smell bilge area for fuel vapors	✓	✓	✓			✓
Check and tighten all steering system bolts and connections						✓
Check rudder, tiller arm bolt and safety setscrew						✓
Lubricate rudder stuffing box and steering support tube						✓
Lubricate cables						
Replace cables	If stiffness continues after lubricating					
Check bilge pump operation	✓	✓	✓			✓
Check blower operation	✓	✓	✓			✓



TIGÉ MAINTENANCE SCHEDULE	DAILY	WEEKLY	REGULAR	ANNUAL	EVERY 2 YEARS	70-HRS.
Inspect shaft seal			✓			✓
Check shaft alignment/ensure it is within 0.003"						✓
Check and tighten motor mounts						✓
Tighten pylon and tower mounting bolts	✓	✓	✓			✓
Tighten all hardware and fasteners						✓
Change engine oil and filter (every 50 hrs.)						✓
Change transmission fluid every 300 hrs. or annually				✓		
Change engine coolant					✓	
Check engine oil	✓					
Check transmission		✓				
Check water pickups for debris or marine growth		✓				✓
If equipped with a strainer, check and clean		✓				✓
If operated in salt water, flush engine/cooling system and boat	✓					
IF PROPELLER STRIKES AN OBJECT, INSPECT DRIVE TRAIN IMMEDIATELY!						



## 120-HOUR SERVICE REQUIREMENTS

This service must be performed to keep warranty active. Engine oil and filter must be changed every 50 hours. Please see your dealer.

TIGÉ MAINTENANCE SCHEDULE	DAILY	WEEKLY	REGULAR	ANNUAL	EVERY 2 YEARS	120-HRS.
Smell bilge area for fuel vapors	✓	✓	✓			✓
Check and tighten all steering system bolts and connections						✓
Check rudder, tiller arm bolt and safety setscrew						✓
Lubricate rudder stuffing box and steering support tube						✓
Lubricate cables						✓
Replace cables	If stiffness continues after lubricating					
Check bilge pump operation	✓	✓	✓			✓
Check blower operation	✓	✓	✓			✓
Inspect shaft seal			✓			✓
Check shaft alignment/ensure it is within 0.003"						✓
Check and tighten motor mounts						✓
Tighten pylon and tower mounting bolts	✓	✓	✓			✓
Tighten all hardware and fasteners						✓
Change engine oil and filter (every 50 hrs.)						✓
Change transmission fluid every 300 hrs. or annually				✓		
Change engine coolant					✓	



TIGÉ MAINTENANCE SCHEDULE	DAILY	WEEKLY	REGULAR	ANNUAL	EVERY 2 YEARS	120-HRS.
Check engine oil	✓					
Check transmission		✓				
Check water pickups for debris or marine growth		✓				
If equipped with a strainer, check and clean		✓				
If operated in salt water, flush engine/cooling system and boat	✓					
IF PROPELLER STRIKES AN OBJECT, INSPECT DRIVE TRAIN IMMEDIATELY!						

## 170-HOUR SERVICE REQUIREMENTS

This service must be performed to keep warranty active. Engine oil and filter must be changed every 50 hours. Please see your dealer.

TIGÉ MAINTENANCE SCHEDULE	DAILY	WEEKLY	REGULAR	ANNUAL	EVERY 2 YEARS	170-HRS.
Smell bilge area for fuel vapors	✓	✓	✓			✓
Check and tighten all steering system bolts and connections						✓
Check rudder, tiller arm bolt and safety setscrew						✓
Lubricate rudder stuffing box and steering support tube						✓
Lubricate cables						✓
Replace cables	If stiffness continues after lubricating					
Check bilge pump operation	✓	✓	✓			✓
Check blower operation	✓	✓	✓			✓





TIGÉ MAINTENANCE SCHEDULE	DAILY	WEEKLY	REGULAR	ANNUAL	EVERY 2 YEARS	170-HRS.
Inspect shaft seal			✓			✓
Check shaft alignment/ensure it is within .003						✓
Check and tighten motor mounts						✓
Tighten pylon and tower mounting bolts	✓	✓	✓			✓
Tighten all hardware and fasteners						✓
Change engine oil and filter (every 50 hrs.)						✓
Change transmission fluid every 300 hrs. or annually				✓		
Change engine coolant					✓	
Check engine oil	✓					
Check transmission		✓				
Check water pickups for debris or marine growth		✓				
If equipped with a strainer, check and clean		✓				
If operated in salt water, flush engine/cooling system and boat	✓					
IF PROPELLER STRIKES AN OBJECT, INSPECT DRIVE TRAIN IMMEDIATELY!						



# SECTION 12 TROUBLESHOOTING AND SERVICE

## 220-HOUR SERVICE REQUIREMENTS

This service must be performed to keep warranty active. Engine oil and filter must be changed every 50 hours. Please see your dealer.

TIGÉ MAINTENANCE SCHEDULE	DAILY	WEEKLY	REGULAR	ANNUAL	EVERY 2 YEARS	220-HRS.
Smell bilge area for fuel vapors	✓	✓	✓			✓
Check and tighten all steering system bolts and connections						✓
Check rudder, tiller arm bolt and safety setscrew						✓
Lubricate rudder stuffing box and steering support tube						✓
Lubricate cables						✓
Replace cables	If stiffness continues after lubricating					
Check bilge pump operation	✓	✓	✓			✓
Check blower operation	✓	✓	✓			✓
Inspect shaft seal			✓			✓
Check shaft alignment/ensure it is within 0.003"						✓
Check and tighten motor mounts						✓
Tighten pylon and tower mounting bolts	✓	✓	✓			✓
Tighten all hardware and fasteners						✓
Change engine oil and filter (every 50 hrs.)						✓
Change transmission fluid every 300 hrs. or annually				✓		✓
Change engine coolant					✓	



TIGÉ MAINTENANCE SCHEDULE	DAILY	WEEKLY	REGULAR	ANNUAL	EVERY 2 YEARS	220-HRS.
Check engine oil	✓					
Check transmission		✓				
Check water pickups for debris or marine growth		✓				
If equipped with a strainer, check and clean		✓				
If operated in salt water, flush engine/cooling system and boat		✓				
IF PROPELLER STRIKES AN OBJECT, INSPECT DRIVE TRAIN IMMEDIATELY!						

## 270-HOUR SERVICE REQUIREMENTS

This service must be performed to keep warranty active. Engine oil and filter must be changed every 50 hours. Please see your dealer.

TIGÉ MAINTENANCE SCHEDULE	DAILY	WEEKLY	REGULAR	ANNUAL	EVERY 2 YEARS	270-HRS.
Smell bilge area for fuel vapors	✓	✓	✓			✓
Check and tighten all steering system bolts and connections						✓
Check rudder, tiller arm bolt and safety setscrew						✓
Lubricate rudder stuffing box and steering support tube						✓
Lubricate cables						✓
Replace cables	If stiffness continues after lubricating					
Check bilge pump operation	✓	✓	✓			✓
Check blower operation	✓	✓	✓			✓



TIGÉ MAINTENANCE SCHEDULE	DAILY	WEEKLY	REGULAR	ANNUAL	EVERY 2 YEARS	270-HRS.
Inspect shaft seal			✓			✓
Check shaft alignment/ensure it is within 0.003"						✓
Check and tighten motor mounts						✓
Tighten pylon and tower mounting bolts	✓	✓	✓			✓
Tighten all hardware and fasteners						✓
Change engine oil and filter (every 50 hrs.)						✓
Change transmission fluid every 300 hrs. or annually				✓		✓
Change engine coolant					✓	
Check engine oil	✓					
Check transmission		✓				
Check water pickups for debris or marine growth		✓				
If equipped with a strainer, check and clean		✓				
If operated in salt water, flush engine/cooling system and boat		✓				
IF PROPELLER STRIKES AN OBJECT, INSPECT DRIVE TRAIN IMMEDIATELY!						



## ORIGINAL OWNER INFORMATION

Owner Name: \_\_\_\_\_

Address: \_\_\_\_\_

City: \_\_\_\_\_

State: \_\_\_\_\_

Zip: \_\_\_\_\_

E-mail: \_\_\_\_\_

Boat Number: \_\_\_\_\_

Date of Purchase: \_\_\_\_\_

Dealer: \_\_\_\_\_

## SECOND OWNER INFORMATION

Owner Name: \_\_\_\_\_

Address: \_\_\_\_\_

City: \_\_\_\_\_

State: \_\_\_\_\_

Zip: \_\_\_\_\_

E-mail: \_\_\_\_\_

Boat Number: \_\_\_\_\_

Date of Purchase: \_\_\_\_\_

Dealer: \_\_\_\_\_

**Ask about the transferable warranties.**





## FLOAT PLAN

Copy this page and fill out the copy before you boat. Leave the filled out copy with a reliable person who can be depended upon to notify the USCG or other rescue organization, should you not return as scheduled. Do not file this plan with the USCG.

Name: \_\_\_\_\_

Telephone: \_\_\_\_\_

Description of Boat: \_\_\_\_\_

Type: \_\_\_\_\_

Color/Trim: \_\_\_\_\_

Engine Type: No. of Engines: \_\_\_\_\_

Horsepower: Fuel Capacity: \_\_\_\_\_

Destination Est.: Time of Arrival: \_\_\_\_\_

Expected to Return By: \_\_\_\_\_

If Not Returned By: \_\_\_\_\_ Call the Coast Guard, or: \_\_\_\_\_

Auto Type: \_\_\_\_\_ License Plate No.: \_\_\_\_\_

Parked: \_\_\_\_\_

Coast Guard Telephone Number: \_\_\_\_\_

Local Authority Telephone Number: \_\_\_\_\_





## SURVIVAL EQUIPMENT

PFDs: \_\_\_\_\_ Flares: \_\_\_\_\_ Mirror: \_\_\_\_\_

Flashlight: \_\_\_\_\_ Paddles: \_\_\_\_\_ EPIRB: \_\_\_\_\_

Water: \_\_\_\_\_ Food: \_\_\_\_\_ Anchor: \_\_\_\_\_

Radio (Yes/No): \_\_\_\_\_ Type: \_\_\_\_\_ Freq.: \_\_\_\_\_

## PERSONS ONBOARD

NAME	AGE	ADDRESS	TELEPHONE

Other Information: \_\_\_\_\_

\_\_\_\_\_

\_\_\_\_\_



SECTION  
**12** TROUBLESHOOTING AND SERVICE

This Page Intentionally Left Blank

# INDEX

## Numerics

120-hour service requirements	...12-7
12-volt ports—throughout the boat	.....7-9
170-hour service requirements	...12-8
20-hour service requirements	....12-4
20RZX/21ZX/23ZX/25ZX	.....7-28
220-hour service requirements	.....12-10
22RZX/23RZX	.....7-28
270-hour service requirements	.....12-11
5-pin wiring connector	.....10-5
70-hour service requirements	....12-5

## A

Accidents	.....3-2, 4-6
Accidents, collisions and giving assistance	.....4-6
Advanced CAN Bus Technology	...1-7
After refueling	.....8-8
Alcohol	.....3-3
Alpha E3 outer armor cover (over tower)—if equipped	.....7-26
Alpha E3 tower	.....7-17
America's Waterway Watch	.....3-6
American Boat & Yacht Council	....1-5
American Red Cross	.....1-5
Anchoring	.....8-21
Anodes	.....11-21
Aquatic Invasive Species (AIS)	....3-9
Aquatic vegetation/weeds	.....5-3
Audible (sound) signals	.....2-25
Audible signaling devices	.....2-14, 2-25
Audible signals	.....6-4

## B

Backing up	.....10-9
Backup camera—if equipped	....7-24
Ballast system	.....9-3
Basic safety rules	.....2-1
Batteries	.....7-13, 11-13
Battery disconnect switch	.....7-12
Before launch	.....8-1

Before operating	.....1-3
Before refueling	.....8-7
Before running	.....8-22
Before towing	.....8-3
Bell	.....6-4
Bilge (bilge pump)	.....7-2
Bilge pump and bilge area	.....11-8
Bilge systems	.....9-4
Blower (engine compartment/ bilge area blower)	.....7-3
Boarding	.....8-3
Boat flags	.....5-4
Boat loading	.....8-4
Boat operator specific guidelines	.....2-36
Boat operator, occupants and participants	.....2-35
Boat owner/operator responsibilities	.....3-1
Boat Owners Association of The United States	.....1-5
Boat system failure	.....4-6
Boat systems	.....9-1
Boating accident	.....3-2
Boating regulations and your responsibilities	.....3-1
Boating terminology	.....1-9
Boating under the influence	.....3-3
BoatU.S. Foundation for Boating Safety Hotline	.....1-5
Bow features of your Tigé	.....7-12
Bridges and shipping channels	....3-5
Buoys	.....6-5, 6-9, 6-10, 6-11, 6-12

## C

Capsizing and flooding	.....4-5
Carbon monoxide (CO)	....2-10, 2-33
Care and cleaning of interior—Cool Touch/Chil Cool™ vinyl	.....11-4
Care and cleaning of interior—standard vinyl	.....11-5
Care and maintenance	.....11-1
Certifications	.....1-3
Checks after operation	.....8-10
Checks during operation	.....8-3



Cleaner recommendations ..... 11-6  
Cleaning agents ..... 3-10  
Cockpit and exterior ..... 7-11  
Cockpit seating ..... 7-13  
Cold water ..... 5-2  
Cold weather ..... 5-2  
Collision ..... 4-6  
Commercial shipping safety zones ..... 3-5  
Communication equipment ..... 4-1  
Controls ..... 7-5  
Convex V Hull/TAPS ..... 1-7  
Courtesy (courtesy lights) ..... 7-3  
Cove cover—if equipped ..... 7-23  
CPR ..... 4-1  
Crossing ..... 6-2  
Cruising limitation ..... 2-30

**D**

Dams and spillways ..... 5-3  
Danger signal ..... 6-4  
Dangerous weather ..... 4-6  
Dark stowage areas ..... 11-7  
Dash panels ..... 7-1  
Daymarks/Dayboards ..... 6-7, 6-10  
Debris ..... 5-3  
Deck and hull ..... 11-10  
Designated occupant seating ..... 2-40  
Develop water sense ..... 2-32  
Distress signaling devices ..... 4-1  
Distress signals ..... 6-4  
Dock and mooring lines ..... 8-10  
Docking ..... 8-10  
Docking (docking lights) ..... 7-3  
Drain plug ..... 11-21  
Driving defensively ..... 2-28  
Dropping anchor ..... 8-21  
Drugs ..... 3-3

**E**

EIDB dual-battery system—  
if equipped ..... 7-13  
Electrical system ..... 9-3, 11-20  
Emergencies ..... 4-1, 4-7  
Emergency assistance ..... 3-4

Emergency preparation  
checklist ..... 4-1  
Emergency stop switch ..... 7-3  
Emissions ..... 3-10  
Engine ..... 9-2  
Engine compartment cover ..... 7-14  
Engine cooling system ..... 11-21  
Engine emergency stop switch  
and lanyard ..... 2-16  
Engine or boat system failure ..... 4-6  
Engine/propulsion/cooling  
system ..... 11-20  
Engines ..... 1-4  
Engine-transom support  
bracket ..... 10-6  
Exhaust emissions ..... 3-10  
Exterior ..... 11-8  
External care ..... 8-18

**F**

Features ..... 7-1  
Features and technology ..... 1-7  
Fire and explosion ..... 4-3  
Fire extinguisher ..... 2-15, 2-16  
Fires ..... 2-16  
First aid/medical emergencies ..... 4-1  
Fishing ..... 3-6  
Flags ..... 5-4  
Flip-up observer's seat—  
if equipped ..... 7-15  
Float plan ..... 12-16  
Flushing the engine ..... 11-19  
Fog conditions ..... 5-2  
Fogging oil ..... 11-20, 11-21  
Freezing temperatures ..... 5-2  
Freshwater cooling ..... 8-19  
Freshwater cooling – half  
systems ..... 8-18  
Fuel (gasoline) ..... 8-5  
Fuel filler ..... 8-7  
Fuel log ..... 12-14, 12-17  
Fuel management ..... 8-4  
Fuel stabilizer ..... 11-21  
Fuel suppliers ..... 8-4  
Fuel system ..... 9-3



Fueling ..... 8-4, 8-6  
Fuses ..... 7-11

## G

Gauges ..... 7-9  
Gelcoat maintenance ..... 11-9  
General layouts ..... 7-1  
General maintenance ..... 11-3  
Gross Vehicle Weight Rating  
(GVWR) ..... 10-2  
Guidelines for participants in the  
water ..... 2-37

## H

Harbor flags and indicators ..... 5-5  
Hazard ..... 2-4, 5-2, 5-4  
Hazard information ..... 2-31  
Heated seats—optional ..... 7-15  
Heater—optional ..... 7-8  
Hitch ball and trailer coupler ..... 10-3  
Horn ..... 6-4, 7-4  
Hurricane and severe weather  
preparedness ..... 4-9  
Hypothermia ..... 4-1, 5-2

## I

Icy waters ..... 5-2  
If you sell your Tigé boat ..... 1-3  
Ignition key switch ..... 7-4  
Inclement weather ..... 5-2  
Inflatables/tube tips ..... 2-38  
Insurance ..... 3-2  
Intended use ..... 1-2  
Interior ..... 11-4  
Internal (cooling system) care ..... 8-18  
Introduction ..... 1-1  
iPod™/MP3 port—optional ..... 7-9  
Isolated danger markers ..... 6-12

## K

Know water sports hand  
signals ..... 2-36  
Knowing the boat ..... 2-29

## L

Lateral markers ..... 6-10

Launch ..... 8-8  
Launching ..... 10-9  
Law of salvage ..... 4-8  
Legal considerations ..... 10-1  
Life jackets ..... 2-14, 2-17, 11-1  
Lighthouses ..... 6-8  
Lights and lighted structures ..... 6-7  
Loading guidelines ..... 10-11

## M

Man Overboard (MOB) ..... 4-4  
Manatee ..... 6-11  
Maneuvering techniques ..... 8-17  
Marine Assistance Request  
Broadcast (MARB) ..... 4-2  
Markers ..... 6-5, 6-9, 6-11  
Markers, warnings and  
advisories ..... 5-4  
Mayday ..... 4-2  
Medical emergencies ..... 4-1  
Meeting head-on ..... 6-3  
Minimum onboard personal  
safety equipment ..... 2-14  
Minor lights ..... 6-7, 6-10  
Minors ..... 3-3  
Monofilament fishing line ..... 3-6  
Mooring boat cover (tower up) -  
if equipped ..... 7-25  
Mooring buoys ..... 6-6

## N

National Association of State  
Boating Law Administrators ..... 1-5  
National Marine Manufacturers  
Association ..... 1-5  
National Oceanic and Atmospheric A  
dministration's National Weather  
Service ..... 1-5  
National Safe Boating  
Council Inc. ..... 1-5  
NAV (navigation lights) ..... 7-3  
Naval vessel protection zones ..... 3-5  
Navigation markers ..... 5-4  
Navigation rules and aids ..... 6-1  
Navigational lights ..... 2-25, 2-26



Navigational lights and night operation ..... 6-13  
Negligent operation ..... 3-4  
Noise ..... 3-7  
Non-skid flooring cleaning instructions ..... 11-7

**O**

Observer ..... 2-36  
Observer's seat ..... 7-14  
Operating in hazardous conditions ..... 5-1  
Operating the boat ..... 8-1  
Operating under the influence ..... 3-3  
Operation by minors ..... 3-3  
Operator's license and education ..... 3-3  
Organizations ..... 1-5  
Original owner information ..... 12-13  
Other special signs and markers ..... 6-11  
Overloading ..... 2-12  
Overtaking/passing ..... 6-4  
Owner responsibility for warranty procedure ..... 1-3  
Owner's kit ..... 1-2  
Owner's manual ..... 1-2

**P**

Paints ..... 3-10  
People with handicaps and elderly people ..... 2-30  
Performance boating ..... 8-22  
Personal location beacon (PLB) ..... 2-27  
Pets ..... 2-30  
Platform dragging ..... 2-33  
Plug and play ballast ..... 7-27  
Ports ..... 7-9  
Preferred channel markers ..... 6-12  
Preflight checklist ..... 8-2  
Pregnant women ..... 2-29  
Pre-operation ..... 8-3  
Product improvement ..... 1-8  
Propeller ..... 11-11

Propellers ..... 8-23, 9-2  
Protecting the boat from theft ..... 4-9  
Protecting the environment ..... 3-8  
Publications ..... 1-4  
Pull-out cleats ..... 7-25

**R**

Range lights ..... 6-8  
Range markers ..... 6-9  
Recommended safety equipment ..... 2-27  
Reduced visibility ..... 5-2  
References and contact information ..... 1-4  
Refueling ..... 8-7  
Refueling built-in fuel tanks ..... 8-8  
Registration ..... 3-2  
Registration certificates ..... 3-2  
Registration numbers ..... 3-2  
Regulations ..... 3-3, 3-7, 3-10, 6-1  
Regulatory markers ..... 6-9  
Reporting accidents ..... 4-6  
Reporting safety defects ..... 10-11  
Requesting assistance (non-distress call) ..... 4-1, 4-2  
Required boating safety equipment and regulations ..... 2-14  
Restricted areas ..... 3-5  
Retractable pylon ..... 7-15  
Ride, safety and boat performance ..... 8-14  
Right-of-way ..... 6-1  
Rudder ..... 11-12  
Rules of the road ..... 6-1  
Running ..... 8-17  
Running aground ..... 4-5

**S**

Safe water markers ..... 6-11  
Safety ..... 2-1, 3-1  
Safety chains ..... 10-4  
Safety equipment ..... 8-2, 11-1  
Safety guidelines ..... 2-2  
Safety labels ..... 2-4  
Safety precautions ..... 2-6

- Safety statements .....2-5  
 Salt and hard water operation .....8-18  
 Salt water .....8-17  
 Saltwater corrosion .....11-12  
 Schematic and system illustrations .....9-9  
 Sea strainer maintenance .....11-18  
 Sea Tow Services International, Inc. ....1-5  
 Seals in the engine lower unit .....3-6  
 Second owner information .....12-13  
 Security zones .....3-5  
 Serial number locations .....1-8  
 Setting the Zero Off GPS cruise control display units .....7-10  
 Severe weather .....5-1  
 Shallow water .....5-3  
 Shallow water boat stability .....3-7  
 Shallow water operation .....5-3  
 Shifter / throttle control .....7-5  
 Shifting .....8-9  
 Shock .....5-2  
 Show lighting .....2-26  
 Signs .....6-11  
 Situational awareness .....2-28  
 Small boats and swimmers .....2-28  
 Smart wheel controls .....7-6  
 Special markers .....6-10  
 Special needs passengers .....2-29  
 Specifications  
 20RZX .....1-22, 1-24, 1-26  
 Specifications 21ZX .....1-14  
 Specifications 23ZX .....1-12  
 Specifications 25ZX .....1-10  
 Specifications Z1 .....1-20  
 Specifications Z3 .....1-16  
 Speed .....3-7  
 Speed limits .....3-7  
 Spillways .....5-3  
 Spotter .....2-36  
 Stainless steel .....11-11  
 Stainless steel and chrome .....11-10  
 Starting .....8-8  
 Static electricity and the fuel system .....8-5  
 Steering .....8-9  
 Steering system .....9-1, 11-16  
 Steering tilt lever .....7-8  
 Stereo remote—optional .....7-8  
 Stern thruster (optional) .....9-5  
 Stopping .....8-10  
 Storage hatch .....7-15  
 Storm conditions .....5-1  
 Storm warning .....5-4  
 Strong points .....2-4  
 Strut and bearing .....9-2  
 SurfLink® remote .....7-8  
 Surge brakes .....10-5  
 Survival equipment .....12-17  
 Swim platform .....7-12  
 Switches, controls, ports, gauges and indicators .....7-2
- ## T
- TAPS 3T .....7-8  
 TAPS 3T operation .....8-13  
 TAPS operation .....8-12  
 The general prudential rule .....6-1  
 Thru-hull fittings .....11-21  
 Tigé clear dash .....7-2  
 Tigé tips for a safe, fun day on the water .....1-1  
 Tigé Zero Off GPS cruise control panel .....7-8  
 Tigé/ATX keyless ignition operation .....7-11  
 To set Zero Off GPS cruise control .....8-15  
 Toddlers .....2-29  
 Towing hitch .....10-2  
 Towing on the water .....4-7  
 Towing procedure .....8-20  
 Towing vehicle .....10-2  
 Trailer .....10-1  
 Trailer brakes .....10-5  
 Trailer classification .....10-1  
 Trailer gross vehicle weight rating .....10-2  
 Trailer regulations .....10-1  
 Trailer type .....10-1



Trailing and launching ..... 10-1  
Trailing guidelines ..... 10-6  
Transmission ..... 9-2  
Transmission oil level  
inspection ..... 11-16  
Transom flip-up seats  
(RZX line) ..... 9-5  
Transom flip-up seats (ZX line) ..... 9-5  
Troubleshooting ..... 8-16  
Troubleshooting and service  
requirements ..... 12-1  
Type B fire extinguishers ..... 2-16

## U

U.S. Coast Guard (USCG) ..... 1-6, 3-1  
U.S. Coast Guard Auxiliary ..... 1-6  
U.S. Coast Guard Navigation  
Center (NAVCEN) ..... 1-6  
U.S. Coast Guard Office of Boating  
Safety ..... 1-6  
U.S. Coast Guard's America's  
Waterway Watch Program ..... 1-6  
U.S. Government Publishing  
Office ..... 1-6  
U.S. Power Squadrons ..... 1-6  
United States Aids to Navigation  
System (USATONS) ..... 6-5  
Unscheduled maintenance ..... 11-20  
Using distress signals ..... 4-1  
Using the platform/boarding  
ladder ..... 2-40

## V

V-drive models ..... 7-14  
V-drives ..... 9-2  
Vegetation ..... 5-3  
Vehicle towing hitch ..... 10-2  
Visibility ..... 5-2  
Visual distress signaling (VDS)  
devices ..... 2-14, 2-22  
Visual distress signals (VDS) ..... 2-24

## W

Wake ..... 3-7  
Walk-thru windshield opening/  
latching ..... 7-13

Warranty service requirements ..... 1-3  
Water hazards ..... 5-2  
Water sports ..... 2-32  
Water sports and towing  
safety ..... 2-43  
Water sports guidelines ..... 2-34, 2-35  
Water sports responsibility  
code ..... 2-44  
Water sports safety ..... 2-41  
Water sports tips ..... 2-48  
Water sports tow pylon safety ..... 7-16  
Weather ..... 4-6  
Weighing (pulling in) anchor ..... 8-22  
When underway ..... 8-23  
Whistle ..... 6-4  
Winterization ..... 8-20  
Winterization and storage  
preparation ..... 11-21

## Z

Z series reversible bench ..... 7-29  
Zero Off GPS cruise control ..... 1-7  
Zero Off GPS cruise control  
operations ..... 8-14











1801 HWY 36  
ABILENE, TX 79602  
[WWW.TIGE.COM](http://WWW.TIGE.COM)